



# PREDATORE<sup>®</sup>



PREDATORE HD PROLINE  
**ADD - ON COMPACTOR**



# PREDATORE®

## PREDATORE HD PROLINE ADD - ON COMPACTOR

The Predatore HD Proline series has evolved and grown from over 20 years of practical use in road construction and civil engineering. Developed and manufactured by professionals for professionals, the robust add on compactors are equipped with all technical refinements, are versatile and are therefore indispensable as real allrounders on every construction site. The use of an add-on compactor not only enables more effective and efficient compaction it also ensures higher utilisation of the carrier equipment and thus a short amortisation period.

Further plus points include the costoptimised, unmanned compaction, a significantly reduced risk of accidents due to mechanical compaction directly on site, as well as compliance with all legal regulations concerning vibrations and exhaust fumes.

The range of applications for the Predatore HD Proline series ranges from mini excavators to 60 tonnes crawler excavators, from compacting surfaces and trenches to compacting deep trenches in the pipe zone.

### AREAS OF APPLICATION:

- > Civil engineering
- > Route and road construction
- > Earthworks
- > Building construction
- > Gardening and landscaping
- > Cable and pipeline construction

### THE ADVANTAGES:

- > Optimum compaction through adjustable frequency and compacting force
- > Enormous depth effect, resulting in high efficiency in all soil conditions
- > Significantly higher utilisation of the carrier – no idling or downtimes
- > Reduction of noise, vibration & exhaust fumes
- > Minimised risk of accidents due to mechanical compaction, also in drainage ditches
- > Avoidance of pipe and environmental damage through controlled compaction, especially in vibration-sensitive areas
- > Short amortisation period through effective mechanical compaction and optimised utilisation of the machines



Selflocking hydraulic slewing gear with worm gear  
- high torque up to 12,900 Nm holding force  
- eccentric arrangement for shoring work  
- built low

Mechanical or hydraulic quick coupler according to customer requirements

Solid steel construction

Only one central hydraulic block, mounted in a protected manner, adjustable oil quantity for different frequencies

Robust engine protection

Large oil circuit, resulting in optimum cooling and lubrication of the moving components

Forklift pockets for better handling

High quality oil motor with optimised cable routing

Vertically mounted antivibration elements, UV protected, resulting in a significantly longer service life

Solid one piece base plate

# PREDATORE ADD - ON COMPACTOR

## POWER CLASS

THE SERIES FOR LARGE-SCALE COMPACTION

Perfect for all compaction work. Whether with or without quick coupler, with or without slewing gear: Like all Predatore Proline compactors, the POWER CLASS compactors are freely configurable and have the following proven benefits:

> Optimal cooling and lubrication due to the large oil circuit

- > High-quality components and a robust overall construction
- > Optionally available, asymmetrically arranged worm gear slewing gear for more versatility in use.

### HD500

FOR CARRIERS FROM 5 TONNES

The design and construction of the HD500 corresponds to our large add-on compactors.

The technology used in this area caters to professional use. Its 500 kg operating weight for carriers from 5 tonnes makes it the ideal working tool, e.g. in gardening and landscaping.

### HD800

FOR CARRIERS FROM 7 TONNES

With an operating weight of 800 kg for carriers from 7 tonnes, the HD800 serves a wide range of carriers. The extremely robust design and the high compacting forces reliably ensure first-class compaction results while providing maximum comfort for the machine operator. An optional controller is available for the HD800 to adapt the frequency to the requirements of different soils, as well as to avoid damage to pipes and surrounding buildings.

### HD 1200

FOR CARRIERS FROM 15 TONNES

The HD1200 is designed for carriers from 15 tonnes and thus serves a wide range of models.

The HD1200 is also characterised by an extremely stable and durable construction as well as an optimal compaction performance.

### HD1500

FOR CARRIERS FROM 20 - 60 TONNES

With an operating weight of 1.5 tonnes, the add-on compactor is perfect for use on carriers from 20 to 60 tonnes. Even within its class, the HD1500 guarantees unbeatable compaction results with maximum convenience for the machine operator.

### HD2000

FOR CARRIERS FROM 20 - 60 TONNES

With an immense compacting force of 20,000 kg at 40 Hertz, the HD2000 sets new standards worldwide that remain unrivalled. With a plate size of over 1.7 m<sup>2</sup>, it is ideal for large-volume compaction work with heavy equipment.

## ADDITIONAL OPTIONS

- > Controller
- > Extension plate  
(further information on the following pages)
- > Available without standard slewing gear

## PROVEN COMPACTION TECHNOLOGY FOR EXCAVATORS FROM 3 TO 60 TONNES

The add-on compactors of the Predatore Power Class are designed for surface compaction and simplify daily tasks.



PREDATORE®

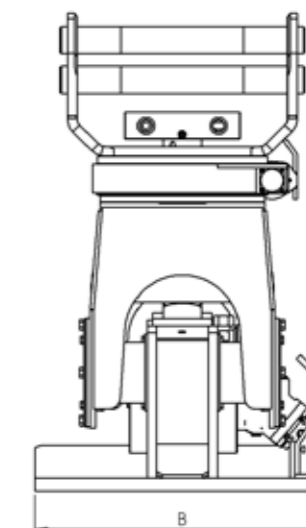
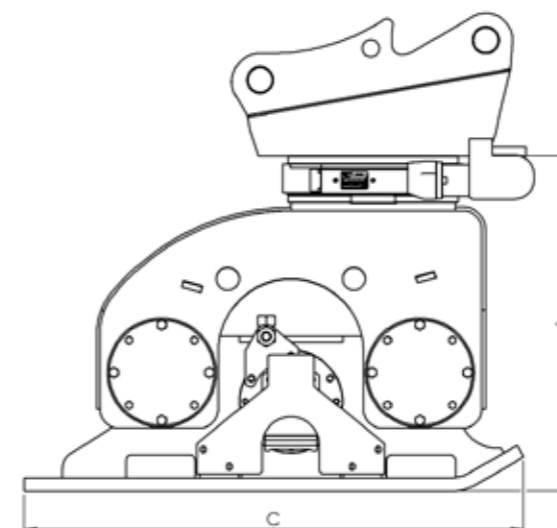

MODEL		HD500	HD800	HD1200	HD1500	HD2000
Excavator service weight	t	5,0 - 10,0	7,0 - 20,0	15,0 - 30,0	20,0 - 60,0	20,0 - 60,0
Operating weight	kg	470	780	1170	1470	1800
Frequency range	Hz	28 - 60	28 - 60	28 - 60	28 - 60	28 - 50
Oil flow	l/min	60	90	150	210	210
Operating pressure	max. bar	210	210	210	210	210
Dyn. compacting force	kg	1000 - 4400	2000 - 8300	3500 - 15000	5000 - 21000	10000 - 30000
Plate size	mm	510x865	660x1100	770x1320	900x1460	1100x1550
Dimensions (BxCxA)	mm	510x865x645	660x1100x785	770x1320x875	900x1460x940	1100x1550x990
Extension plate	mm	1000	1200	1600	2000	2000



## PREDATORE ADD - ON COMPACTOR COMPACT CLASS

THE IDEAL CHOICE FOR MINI AND COMPACT EXCAVATORS

Design and construction correspond to those of the larger models. Technology and performance are designed for professional use and are unbeatable within this size class. The small models are primarily used in gardening and

landscaping, but with the narrow base plate they are also ideal for the efficient compaction of narrow trenches, e.g. in cable and pipeline construction.

### HD250 FOR CARRIERS FROM 1.5 - 6 TONNES

The new compact model is suitable both for compacting in trenches and for compacting small areas and is available with and without a slewing gear.

### HD300 FOR CARRIERS FROM 3 - 8 TONNES

The proven quality, a weight of less than 300 kg and a plate width of 45 cm make the HD300 perfect for all compaction work.

## ADDITIONAL OPTIONS

- > Extension
- > Extension plate  
(further information on the following pages)
- > Available without standard slewing gear

## PREDATORE ADD - ON COMPACTOR LIGHT CLASS

THE SERIES FOR THE MEDIUM PRICE SEGMENT

This model series was developed as a supplement to the tried-and-tested compactor series, but it meets the highest quality standards without any compromises.

### HD1400 FOR CARRIERS FROM 14 - 40 TONNES

With high compacting forces and a directed vibration, the HD1400 ensures optimal compaction results.

MODEL		HD250	HD300	HD1400
Excavator service weight	t	1,5 - 6,0	3,0 - 8,0	14,0 - 40,0
Operating weight	kg	240	280	1210
Frequency range	Hz	28 - 60	28 - 60	28 - 60
Oil flow	l/min	30	30	150
Operating pressure	max. bar	160	160	210
Dyn. compacting force	kg	580 - 2600	1000 - 3400	6000 - 18500
Plate size	mm	380x740	450x800	850x1370
Dimensions	mm	380x740x560	450x800x585	850x1370x875
Extension platez	mm	750	900	X



**PREDATORE ADD - ON  
COMPACTORS  
FOR NARROW  
DITCHES**

**HD200  
FOR CARRIERS FROM 3 TO 60 TONNES**

Despite its compact design, the HD200 is characterised by its robustness. With a plate width of only 280mm, it is the perfect tool for drainage ditch and pipeline construction.



**PREDATORE ADD - ON COMPACTOR  
PIPE ZONE COMPACTOR  
FOR EFFICIENT DRAINAGE DITCH CONSTRUCTION**

Efficient drainage ditch construction is hardly possible without pipe zone compactors. A perfect compaction result is absolutely necessary in the pipe zone, especially if pipe damage after installation is to be avoided. The simple handling and the small space requirement enable optimal compaction even in narrow pipe trenches or at great depths. Compaction work around pipes and manholes are carried

out reliably, quickly and safely without anyone in the ditch. The powerful add-on compactors are safe to operate and comply with the legal regulations in terms of respiratory protection devices when operating compactors with combustion engines in ditches.

**HD200TL  
FOR CARRIERS FROM 10 - 60 TONNES**

Thanks to the enormous compacting force of up to 4500 kg, efficient compaction with maximum dumping heights is possible. The long version of the HD200TL is ideally suited for pipes up to DN 2200.

**HD200TS  
FOR CARRIERS FROM 10 - 60 TONNES**

The HD200TS corresponds to the HD200TL in terms of technology, function and performance and can be used as a short version for pipes up to DN 1400.

MODEL		HD200 TL	HD200 TS	HD200
Excavator service weight	t	10,0 - 60,0	10,0 - 60,0	5,0 - 60,0
Operating weight	kg	800	750	300
Frequency range	Hz	28 - 60	28 - 60	28 - 60
Oil flow	l/min	100	100	60
Operating pressure	max. bar	210	210	210
Dyn. compacting force	kg	1500 - 4500	1500 - 4500	800 - 3500
Plate size	mm	280x750	280x750	280x750
Dimensions	mm	280x750 (695) x2455	280x750 (695) x1655	280x750x755
Extension plate	mm	400	400	400





# PREDATORE®

## PREDATORE MACHINES GMBH

Blankener Str. 31 B  
D-32257 Bünde

**T:** +49 (0) 5223-65705-0

**F:** +49 (0) 5223-65705-90

**E:** [info@predatore.net](mailto:info@predatore.net)



[PREDATORE.NET](http://PREDATORE.NET)