

ironlev



Systems for sliding windows and doors



Magnetic levitation systems for Panoramic Sliding and Lift-and-Slide windows and doors



Beyond the limits of the wheel



Ironlev ferro-magnetic levitation enables the contactless and friction-free movement of doors and windows. Magnetic suspension is obtained by combining a magnetic slider with an iron rail.

The use of the latest generation permanent magnets ensures the movement of weights without an electrical supply. The levitation eliminates any sliding friction and component wear.

The movement is free from the weight, surpassing the limits imposed by the wheel.



Ironlev technology enables large, extremely heavy windows and doors to slide in a frictionless environment, without any electricity input, as if they were free from the effects of gravity.

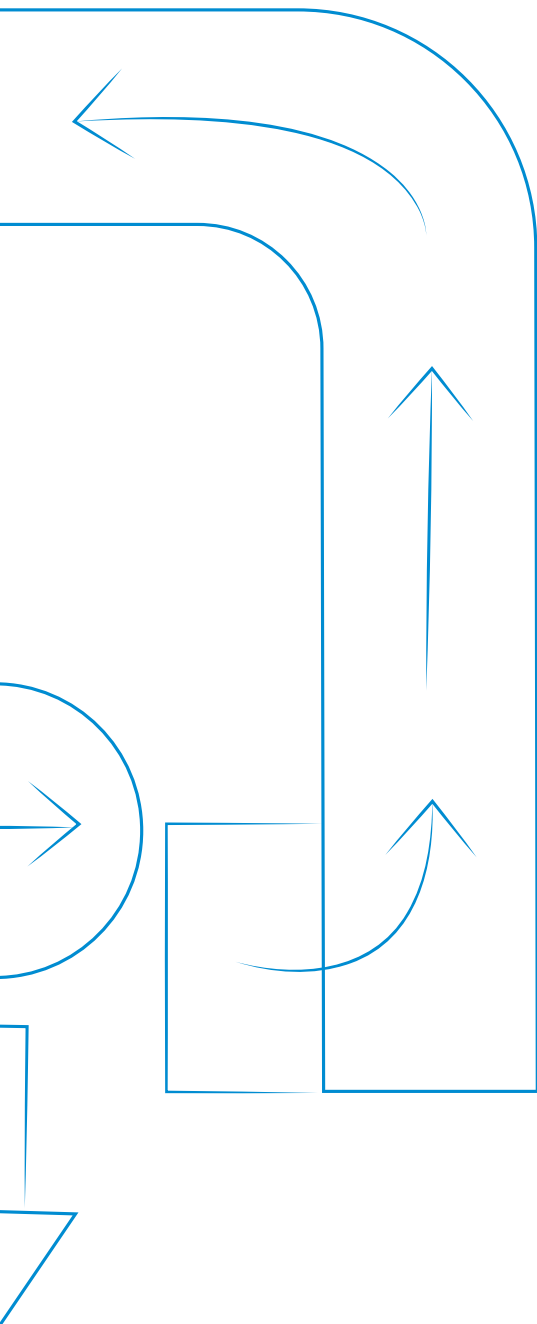

SAFETY

Ironlev system is intrinsically safe: the magnetic field is totally confined inside the slider section, thus eliminating external magnetic dispersion and induced magnetism. This enables the use in domestic environments, as the system can be also installed in the lower part of the window or door.

The intensity of dispersed magnetic field is far lower than the limits imposed by the European directives.

MODULARITY

The composition of the sliders enables to determine their number based on the sash weight.

Unlike traditional wheeled systems, magnetic levitation distributes the weight of the profile and glass evenly between each slider, making it possible to create wide openings using minimal frames.

EASY INSTALLATION AND ASSEMBLY





Ironlev system is designed for easy and safe installation. The sliders are assembled by special accessories that guide the system into the housing of the profile. In addition, the system is equipped with connector elements to fix the track.





Slim

Magnetic levitation sliding system for minimal panoramic sliding windows and doors. “Slim” Ironlev slider enables to upgrade to magnetic sliding, by perfectly integrating even inside the most compact and minimal profiles.



Product and accessories

PRODUCT	DESCRIPTION	CODE	PACKAGE QTY.
	Slim Slider	WD36804	Box: 20 pces Pallet: 960 pces
	Single Interface clip	100411	40 pces
	Double Interface clip	100412	20 pces
	Mounting tool	100427	1 pce
	Rail connector assembly	100510	4 pces

PRODUCT	DESCRIPTION	CODE	PACKAGE QTY.
	Iron rail : d9mm Bar: 3m	100424	4 pces
	Iron rail : d9mm Bar: 6m	100425	4 pces
	Connection bar 1m	100709	4 pces
	Double-sided adhesive 3M VHB GPH-060 3x0.6mm x 33m	100563	3 pces

Technical data

Load capacity
25 kg

Overall dimensions (mm)
180x31x21,1

Rail section diameter
9mm

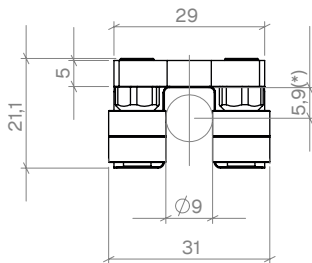
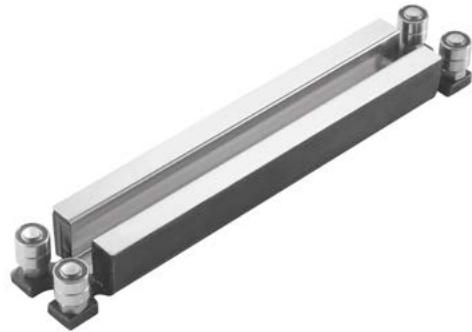

(*): 25 kg nominal position

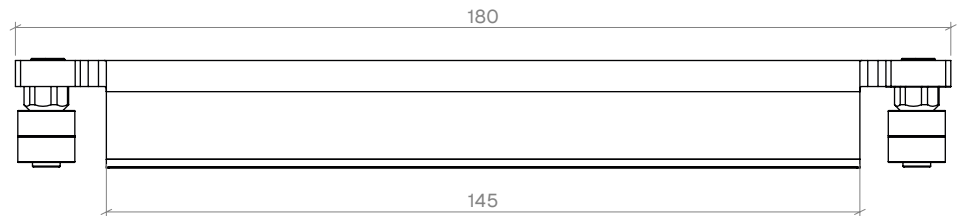

MODULE CONFIGURATION

The system can be configured with single rail for compact profiles and with double rail for heavier loads.

SIZE	MODULE	CAPACITY		LINEAR CAPACITY		PITCH
		Max. load		Max. load		Min. pitch
		kg	lb	kg/m	lb/ft	mm
Slim	Single	25	55	125	84	184
Slim	Double	50	110	250	168	184

INDICATIONS HOW TO SELECT THE NUMBER OF THE SLIDERS AND THEIR POSITIONING

Ironlev system includes a series of magnetic sliders placed on a sliding track. The plastic connection interface is fixed by a quick coupling to the slider, enabling and ensuring the thermal cutting.

For optimum functioning it is suggested to use the slider with a load range between 15 and 25 kg per slider.

The number of sliders to be used is based sash weight, by applying the following formula:

$$\text{Number of sliders} = \text{sash weight} / 25 \text{ Kg}$$

MULTIPLE CONFIGURATIONS OF USE

The modularity and compactness of the various components allow Ironlev system to be used in sliding systems with protruding or recessed threshold with single rail for compact profiles or with double rail for heavy loads.

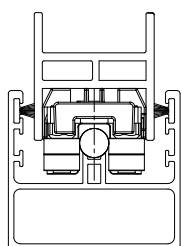

Single protruding threshold

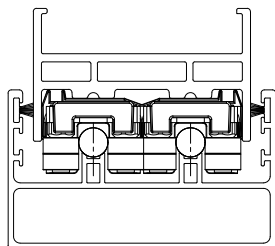

Double protruding threshold

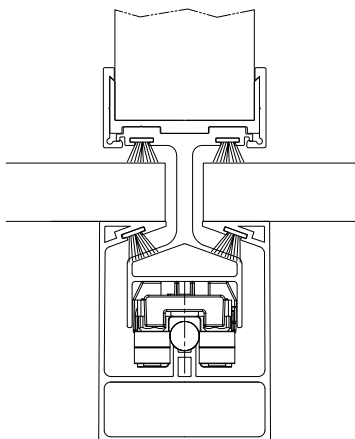

Single recessed threshold

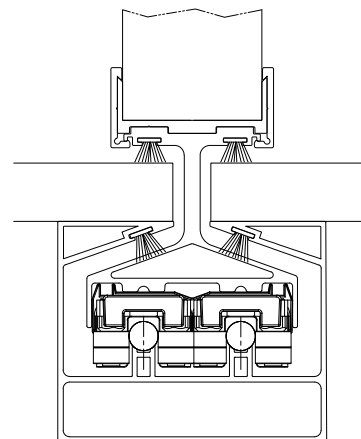

Double recessed threshold

PERFORMANCE AND TESTS PERFORMED

SALT SPRAY TEST	CYCLIC TEST
1.000 hours	100.000 cycles

Assembly instructions

- 1** Position the ferro-magnetic rail and apply the connectors if required. Fix the rail by using the appropriate double-sided adhesive.

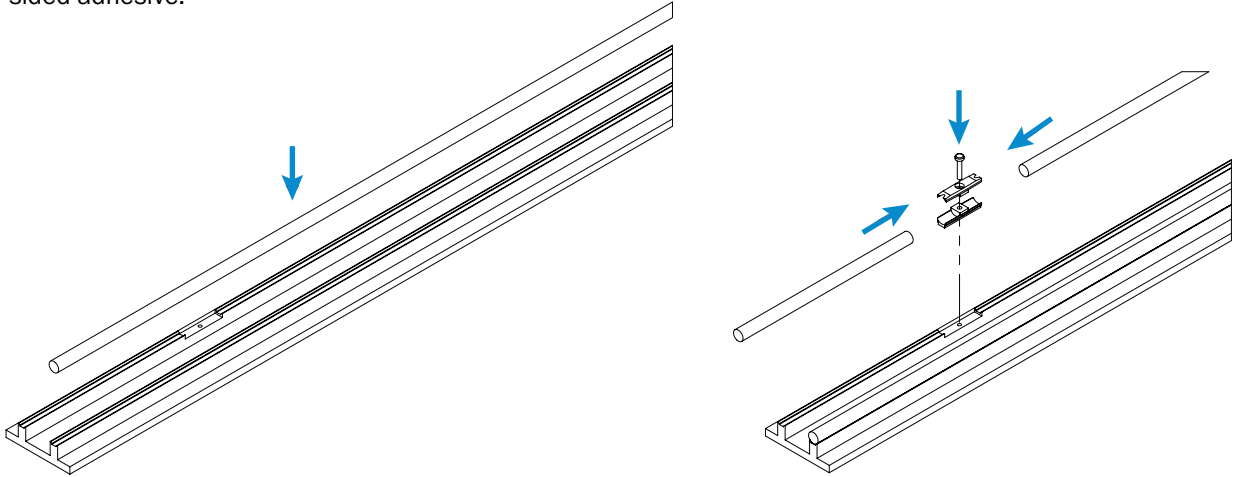

- 2** Insert the sliders onto the rail by using the appropriate insertion tool.

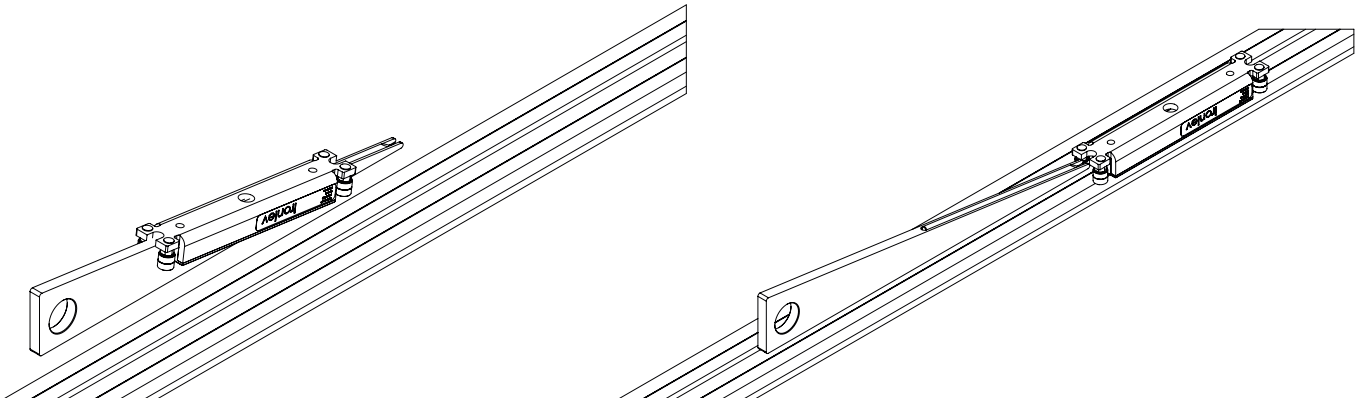

- 3** Apply the interface clips by coupling the sliders together, if in case of double configuration.

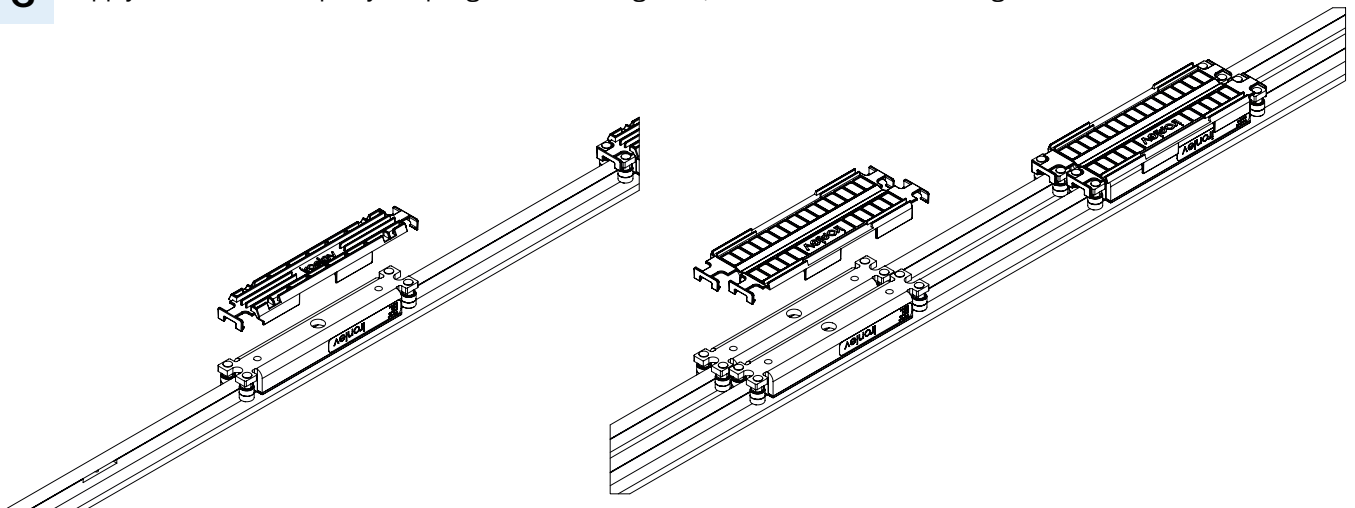

- 4** Position the modules at the correct desired distance between centers and connect them to each other longitudinally by using the connection rod.

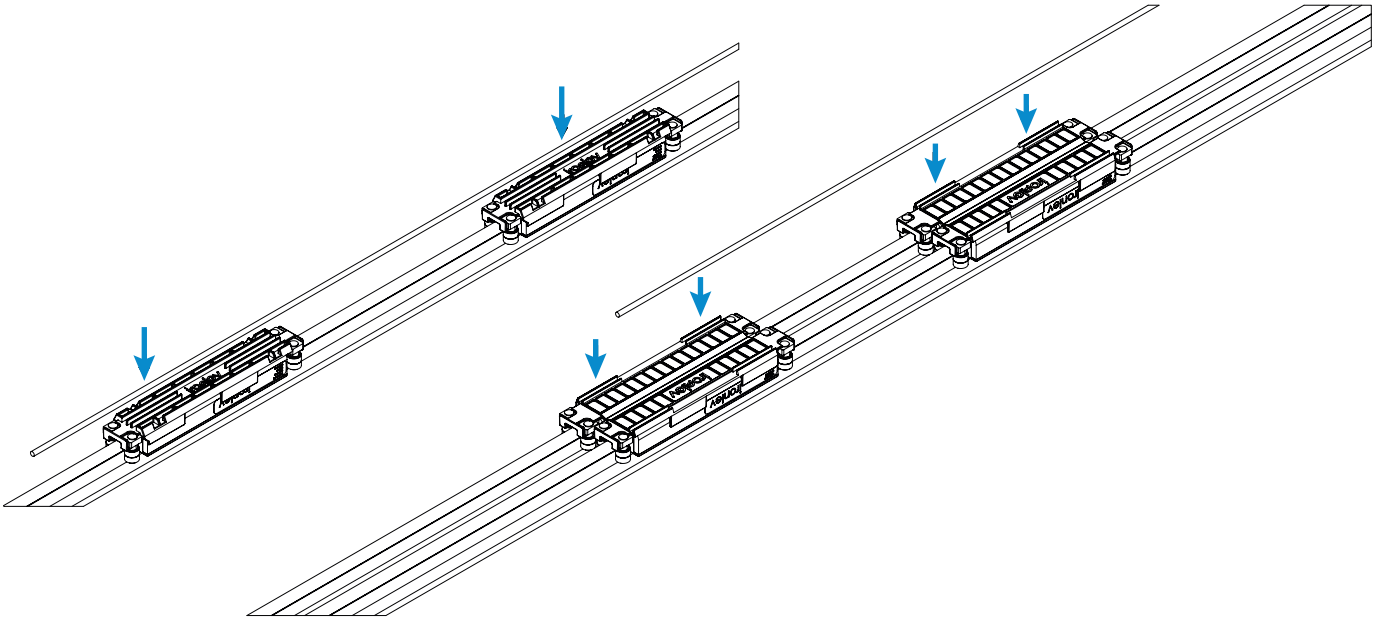

- 5** Proceed with the assembly of the window or door by positioning it on the slider units. Check the balance by arranging the sliders symmetrically with respect to the center of the window or door.

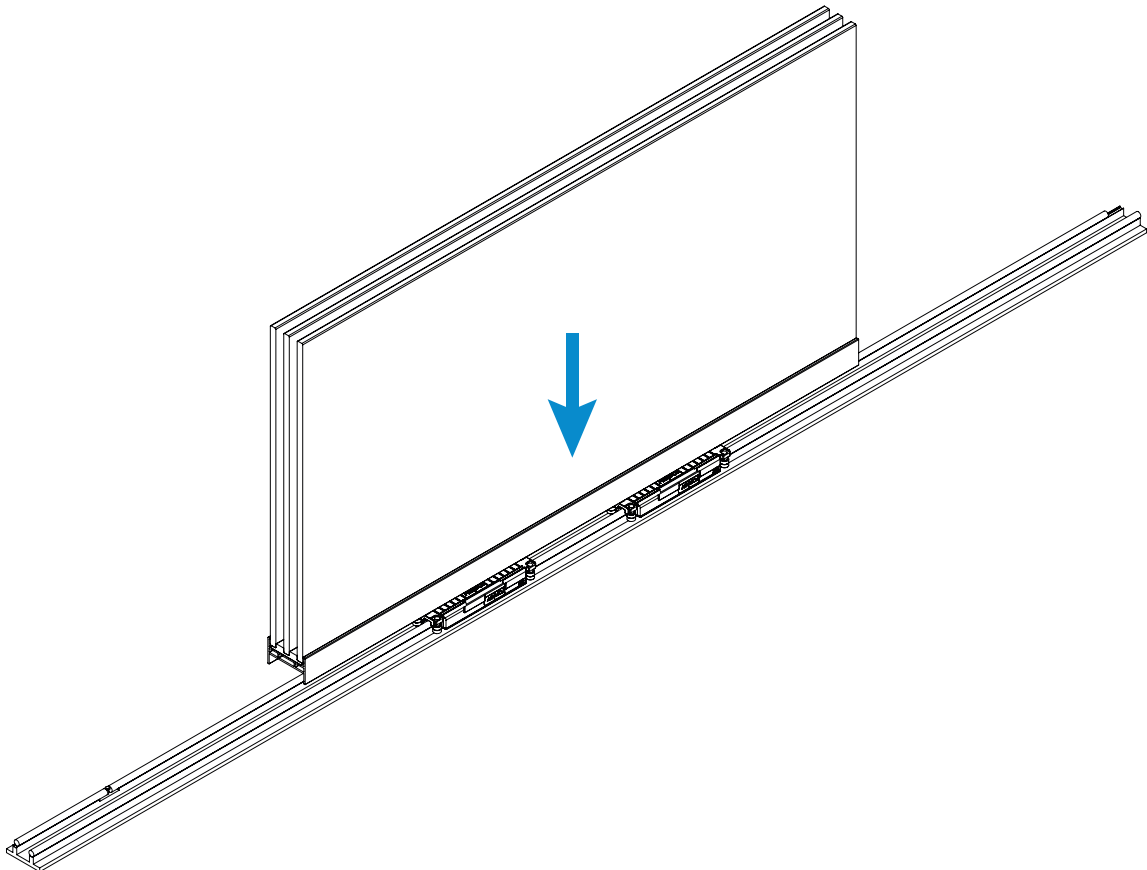











Medium





Ironlev magnetic levitation systems for Lift-and-Slide windows and doors. “Medium” Ironlev slider enables standard windows and doors to be upgraded to magnetic sliding, defining a new standard for sliding and drastically reducing the lifting effort.







Product and accessories

PRODUCT	DESCRIPTION	CODE	PACKAGE QTY.
	Medium Slider	WD37001	Box: 12 pces Pallet: 480 pces
	Sliding module Connection interfaces	100578	12 pces
	Sliding module with connection Connection interfaces	100579	12 pces
	Lifting module for upper rail Connection interfaces	100580	12 pces
	Lifting module for round rail Connection interfaces	100581	12 pces

PRODUCT	DESCRIPTION	CODE	PACKAGE QTY.
	Iron rail: d12mm - 3m	100540	4 pces
	Iron rail: d12mm - 6m	100426	4 pces
	Iron rail: d12mm with holes - 3m	100582	4 pces
	Iron rail: d12mm with holes - 6m	100583	4 pces
	Upper rail		
	6m - silver	100541	4 pces
	6m - black	100712	4 pces
	3m - silver	100713	4 pces
	3m - black	100714	4 pces
	Mounting tool	100558	1 pce
	Rail connector pin	100584	10 pces

PRODUCT	DESCRIPTION	CODE	PACKAGE QTY.
	Self-threading M6x8 screw	100413	10 pces
	Lifting module Standard interface profile High - 1m	100585	3 pces
	Lifting module Standard interface profile Low - 1m	100586	3 pces
	Lifting module Standard interface profile Extra-low - 1m	100587	3 pces
	Lifting module Pre-assembled interface profile High - 3m	100588	1 pce

PRODUCT	DESCRIPTION	CODE	PACKAGE QTY.
	Lifting module Pre-assembled interface profile Low - 3m	100589	1 pce
	Lifting module Pre-assembled interface profile Extra-low - 3m	100590	1 pce
	Double-sided adhesive 3M VHB GPH-060 5x0.6mm x 33m	100710	3 pces
	Double-sided adhesive 3M VHB 9473 5x0.25mm x 55m	100711	2 pces

Technical data

Load capacity
50 kg

Overall dimensions (mm)
199x45x41,2

Rail section diameter
12mm

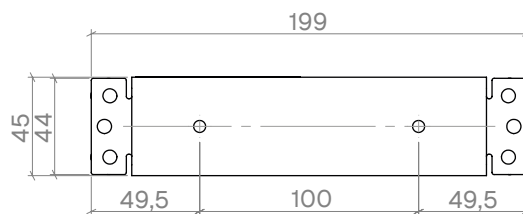
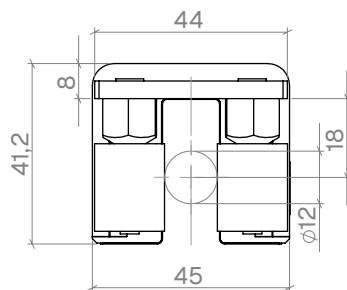

LIFT-AND-SLIDE SYSTEMS

For optimum functioning of the system with the Lift-and-Slide version, it is necessary to apply a correct number of sliders, depending on the sash weight.

Ironlev system supports the weight of the window or door, allowing the use of more compact lifting hardware, thus reducing the height of the sash profile.

Reducing the lifting effort enables the use of smaller handles, offering new design solutions.

LOAD RANGE - SASH WEIGHT (KG)		NUMBER OF SLIDERS	MAX. LOAD ON HARDWARE
Min	Max		kg
70	139	1	84
140	209	2	99
210	279	3	114
280	349	4	129
350	419	5	144
420	489	6	159
490	559	7	174
560	629	8	189
630	699	9	204
700	769	10	219
770	839	11	234
840	909	12	249
910	979	13	264
980	1049	14	279

INTEGRATION WITH LIFTING HARDWARE

Depending on the hardware used, different interface profiles are available (high, low, extra-low).

To allow the use of a traditional carriage, an optional profile is available to be applied on the round rail to adapt to the profile of the standard wheels.

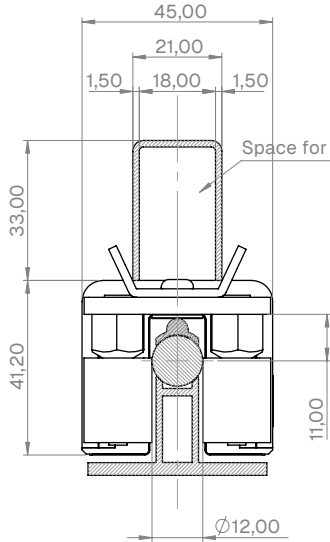

High
42mm

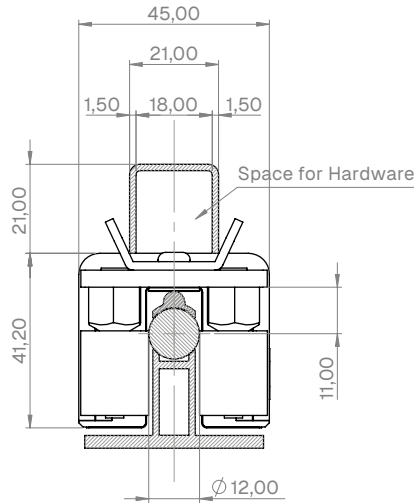

Low
30mm

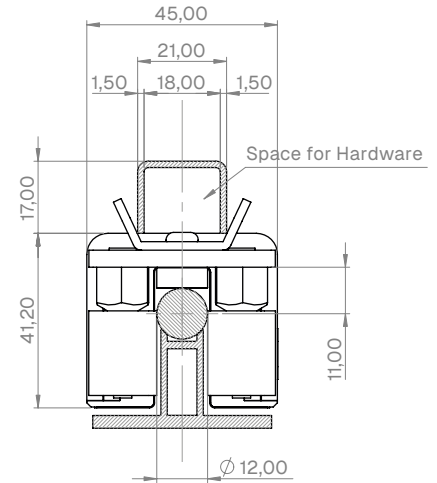

Extra-low
Customized

SLIDING SYSTEMS

“Medium” slider can also be used for non-lifting sliding systems, allowing high load capacities to be obtained with a smaller profile width compared to the configuration with double module “Slim” slider.

For optimum functioning it is suggested to use the slider with a load range between 30 and 50 kg per slider. The number of sliders to be used is based on the sash weight, by applying the following formula:

$$\text{Number of sliders} = \text{sash weight} / 50\text{kg}$$

SIZE	MODULE	LOAD		LINEAR LOAD CAPACITY		PITCH
		Max. load		Max. load		Min. pitch
		kg	lb	kg/m	lb/ft	mm
WD Medium Exterior	Sliding	50	110	250	168	200

PERFORMANCE AND TESTS PERFORMED

SALT SPRAY TEST	CYCLIC TEST
1.000 hours	100.000 cycles

Module assembly

MODULE CONFIGURATION

The system can be used for a non-lift sliding window or door, or alternatively it can be combined with a Lift-and-Slide system. Use sliding modules for purely sliding systems and lift modules for Lift-and-Slide systems.

Depending on the type of window or door and for optimum functioning, apply the respective interfaces using a 2.5mm hex wrench.

SLIDING SYSTEMS

1 Interface for slider in a sliding configuration

code: 100578

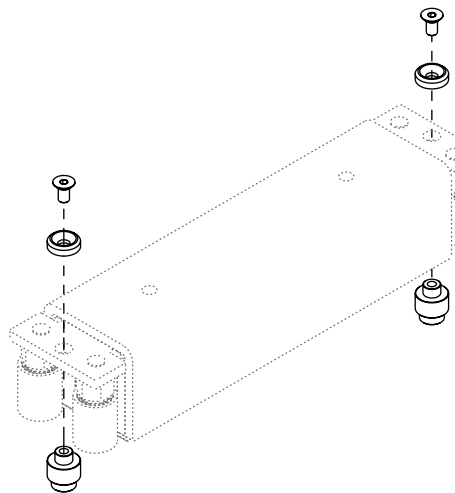

2 Interface for slider in a sliding configuration with connection

code: 100579

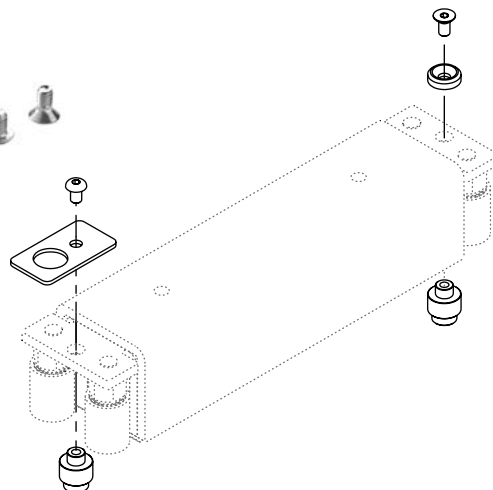

LIFT-AND-SLIDE SYSTEMS

1 Interface for slider in a lifting configuration for housing on upper rail

code: 100580

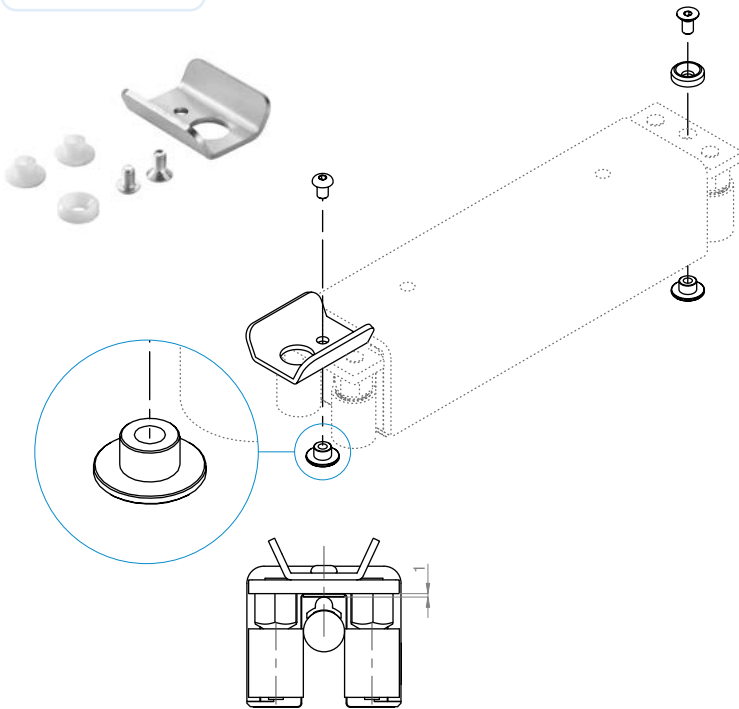

2 Interface for slider in a lifting configuration for housing on round rail

code: 100581

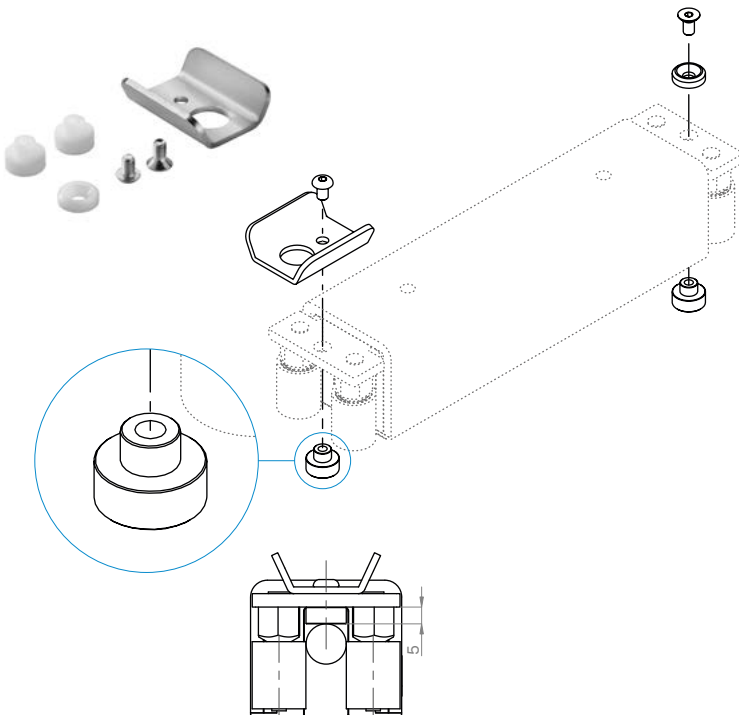

Assembly instructions

SLIDING SYSTEM

- 1 Position the ferro-magnetic rail and apply the connector pins if required. Fix the rail by using the appropriate double-sided adhesive.

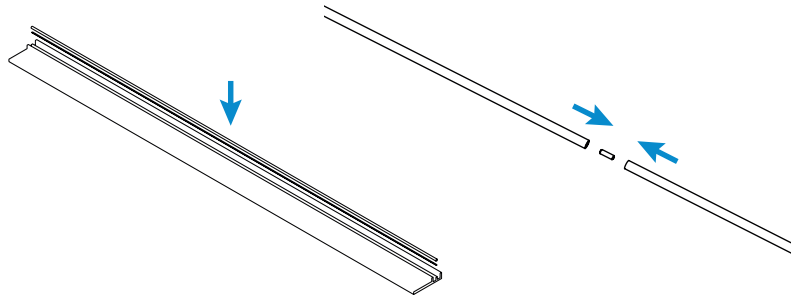

- 2 After positioning the rail and inserting the sliders using the appropriate tool, couple the sliders together by applying light pressure so that the connection interfaces are in position.

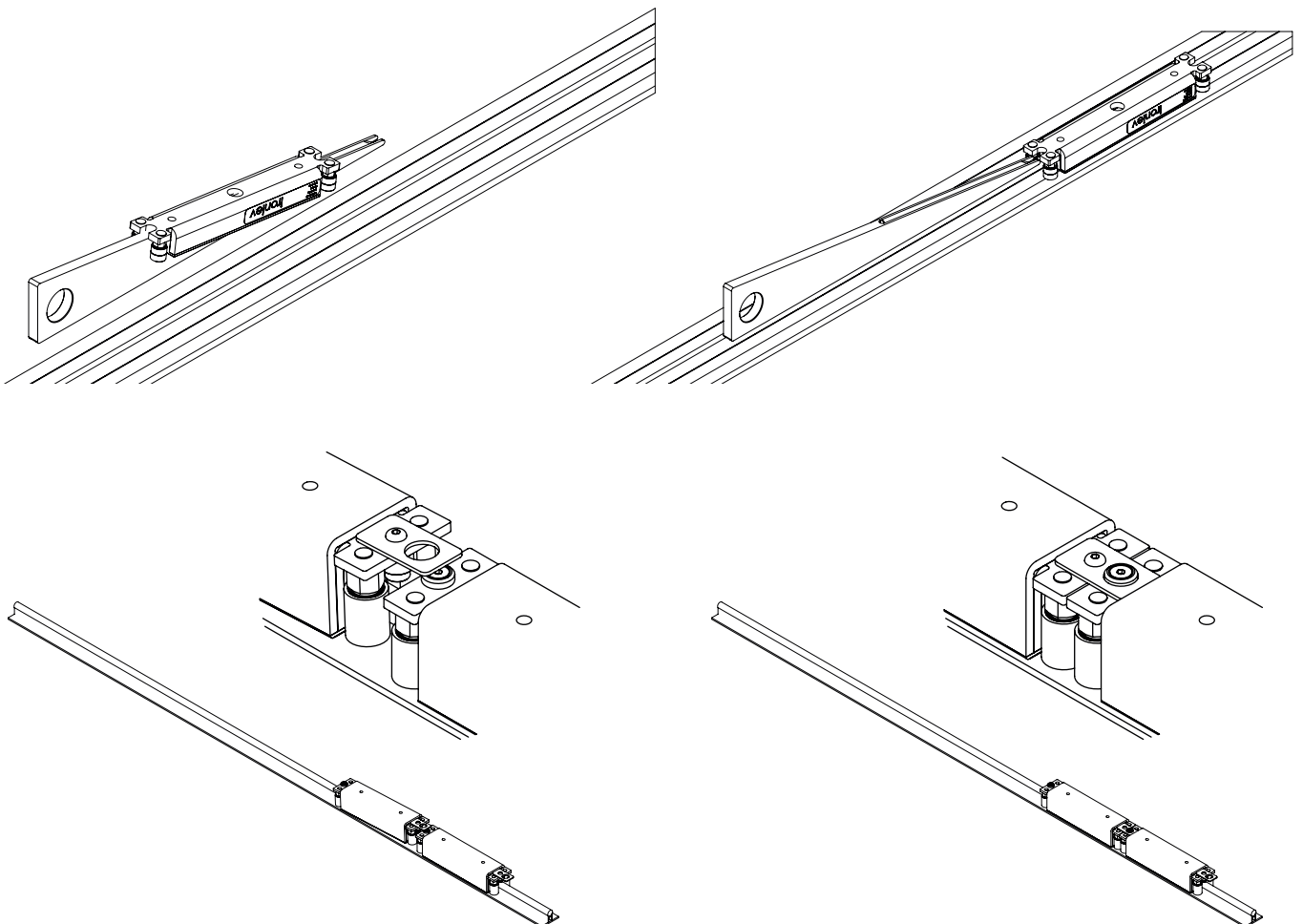

- 3** The sliders can be used without the connection interface by connecting the profiles to the sliders by means of screws (code 100413). All sliders are equipped with dedicated holes.

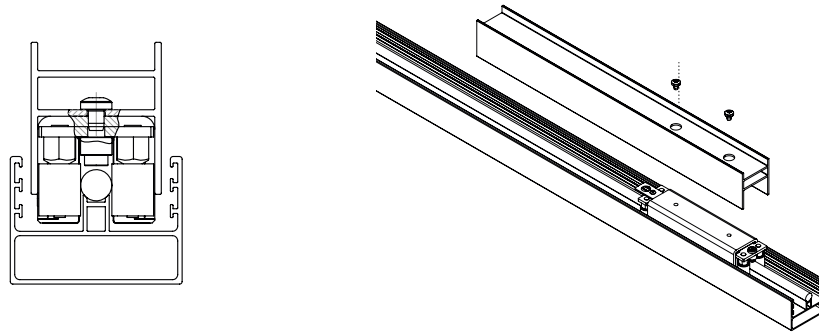

- 4** Place the sash onto the sliders. Balance the load by positioning the sliders symmetrically with respect to the center of the sash.

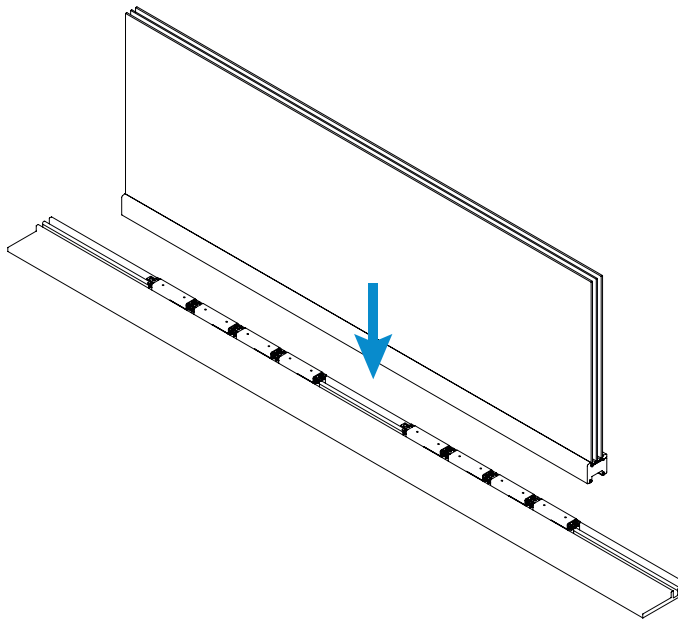

In the sliding configuration without connection interfaces, ensure the correct positioning of the sliders by making appropriate holes on the sash profile.

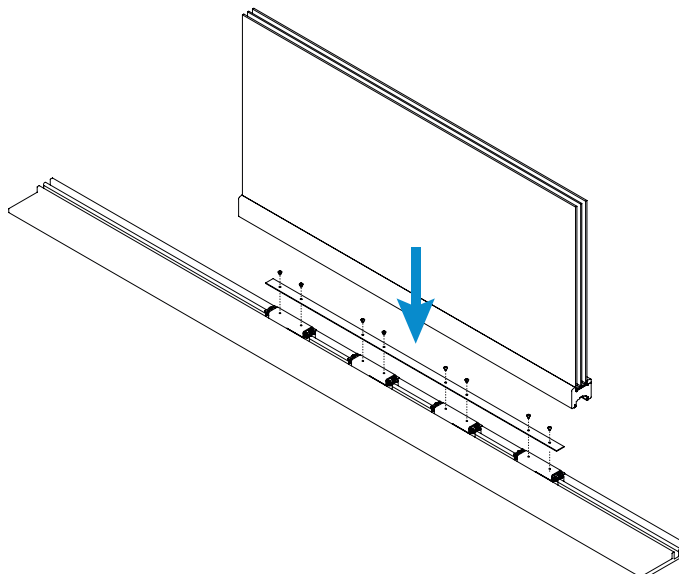

LIFTING SYSTEM

- 1 Position the rail and if any the upper rail profile. Apply the connector pins if required. Fix the rail by using the appropriate double-sided adhesive.

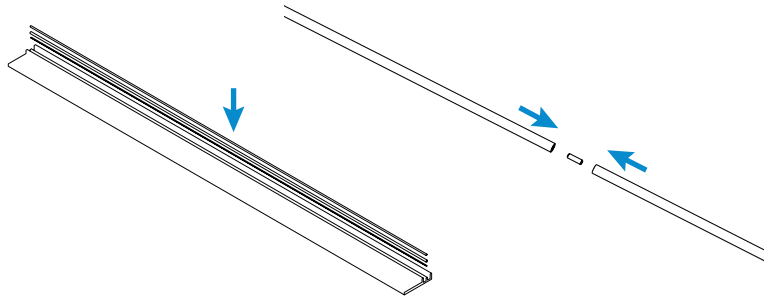

- 2 Fix the wheeled carriages of the hardware to the sash frame and place the interface profile in the space between the two carriages. Connect the two wheeled carriages with the related connection rod, positioning it inside the interface profile.

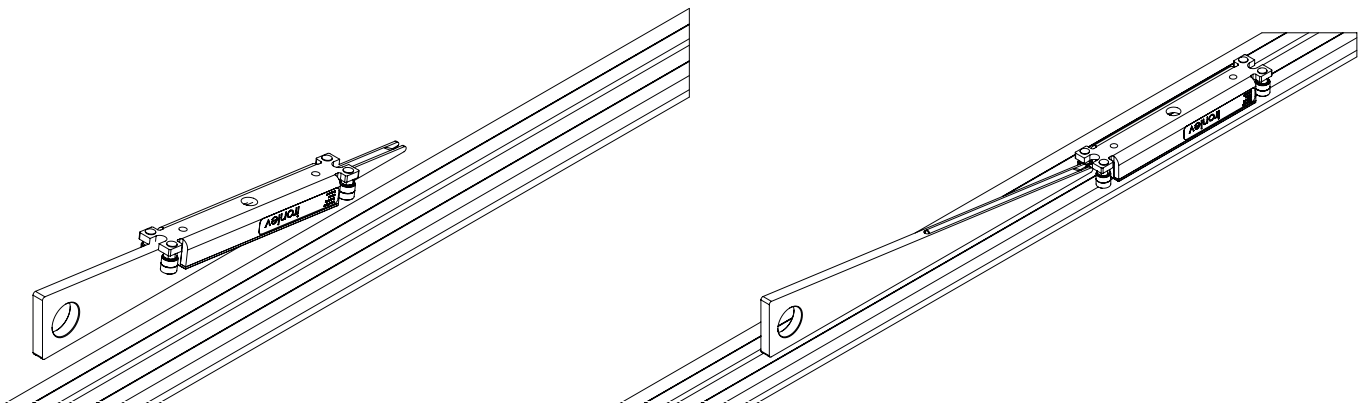
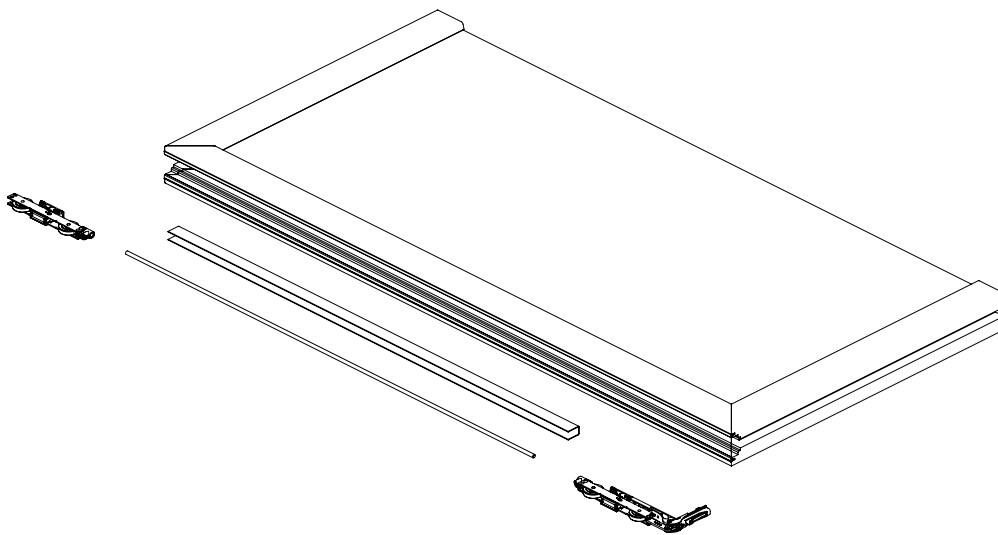

- 3** After arranging the number of Ironlev sliders necessary for the application along the guides, couple the sliders by joining them together with the appropriate connection elements.

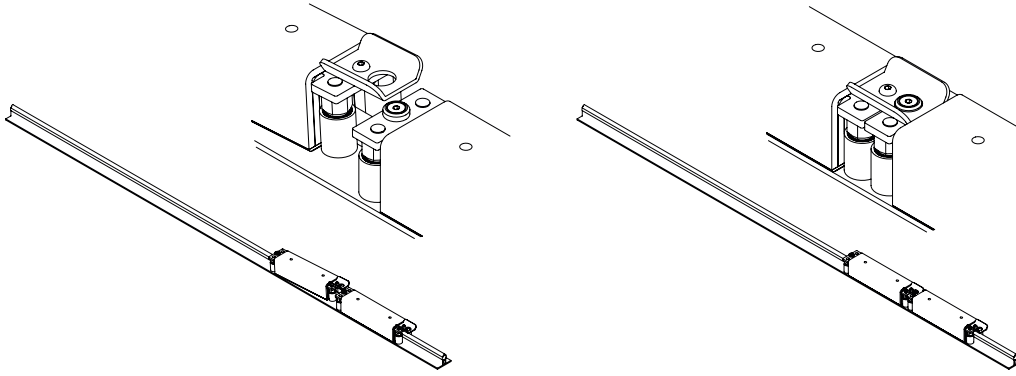

- 4** Proceed with the assembly of the sash. Place it on the guide, checking the correct positioning between the sliders and ensuring that the interface profile fits on the V-shaped clips fixed to the Ironlev sliders. For small sashes, arrange the modules connected together in a single assembly centrally. Check that the positioning of the interface profile fixed to sash corresponds with the position of the modules and that there is no interference with the hardware carriages.

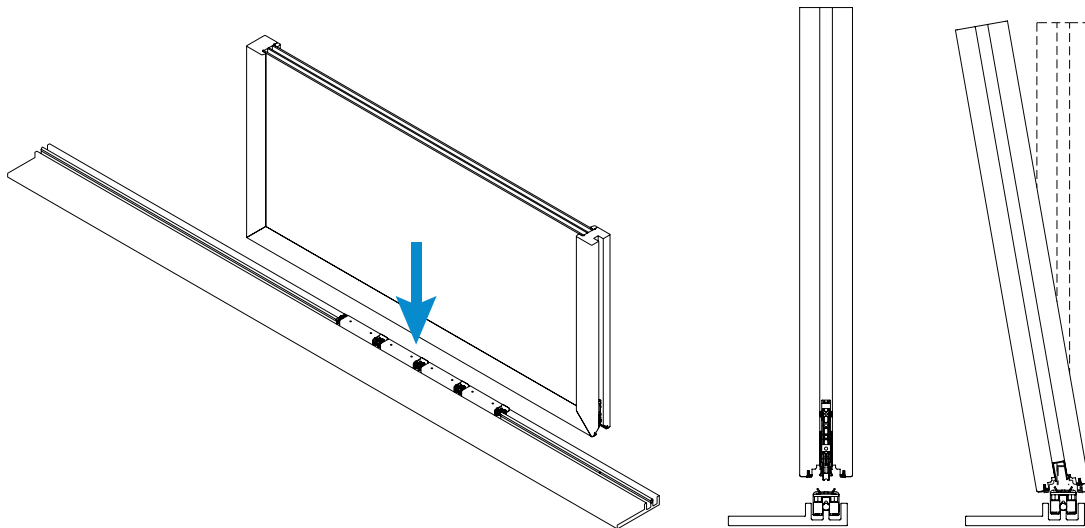

For large sashes, it is suggested to arrange the modules connected to each other in two assemblies to be positioned symmetrically with respect to the sash.

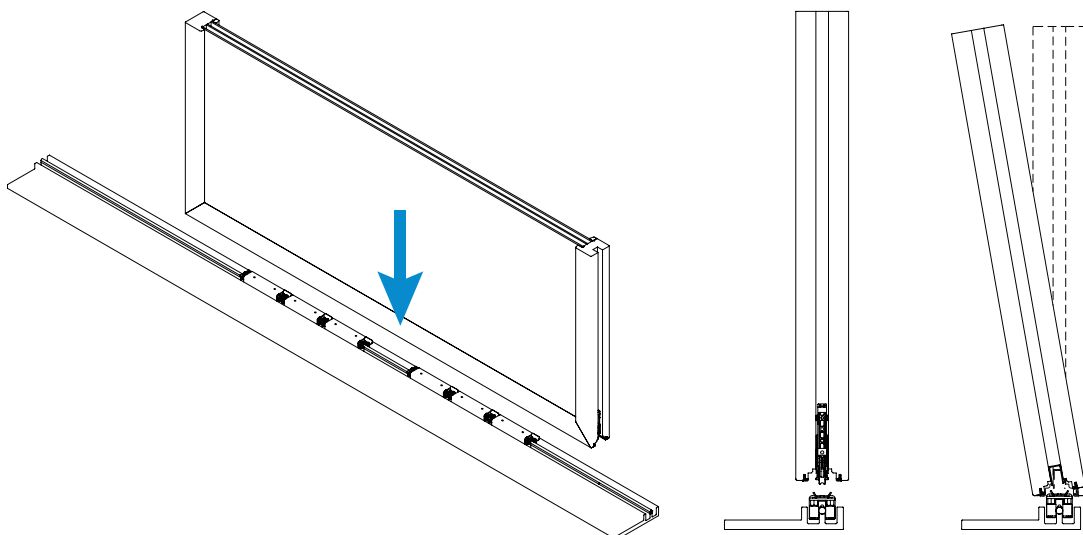

PRE-ASSEMBLED LIFTING SYSTEM

- 1 Position the rail and if any the upper rail profile. Apply the connector pins if required. Fix the rail by using the appropriate double-sided adhesive.

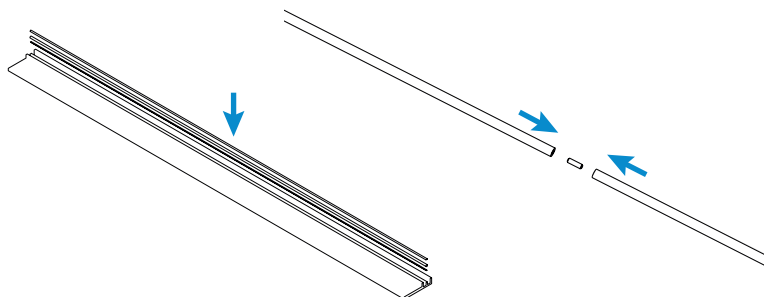

- 2 Fix the wheeled carriages of the hardware to the interface profile. Apply the connection rod and join the two carriages.

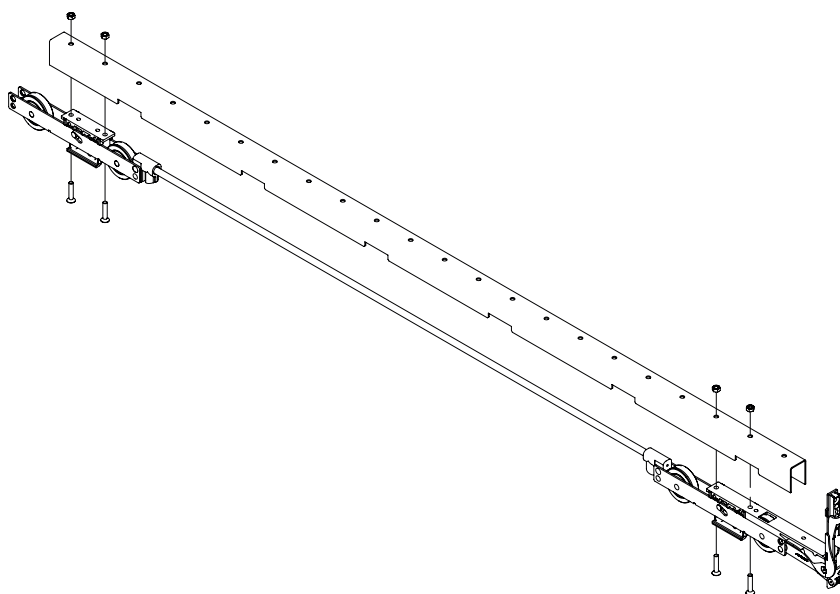

- 3 After arranging the number of Ironlev sliders foreseen for the application along the guides, couple the sliders by joining them together with the appropriate connection elements. Apply the hardware and interface profile assembly to the sliders and create the pre-assembled assembly. Check the correct positioning and that the V-shaped interface clips fit on the respective recesses created in the profile.

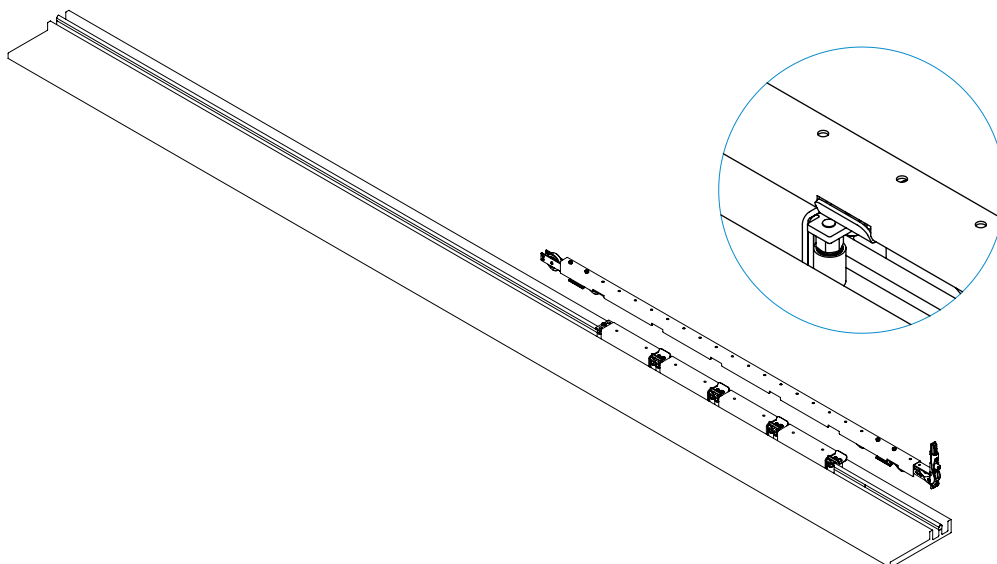

- 4** Proceed with the assembly of the window or door. Place it on the guide laterally with respect to the kit and lift the sash.

Insert the kit by sliding it sideways into the desired slot, checking the correct positioning until the kit comes into contact with the vertical upright of the sash.

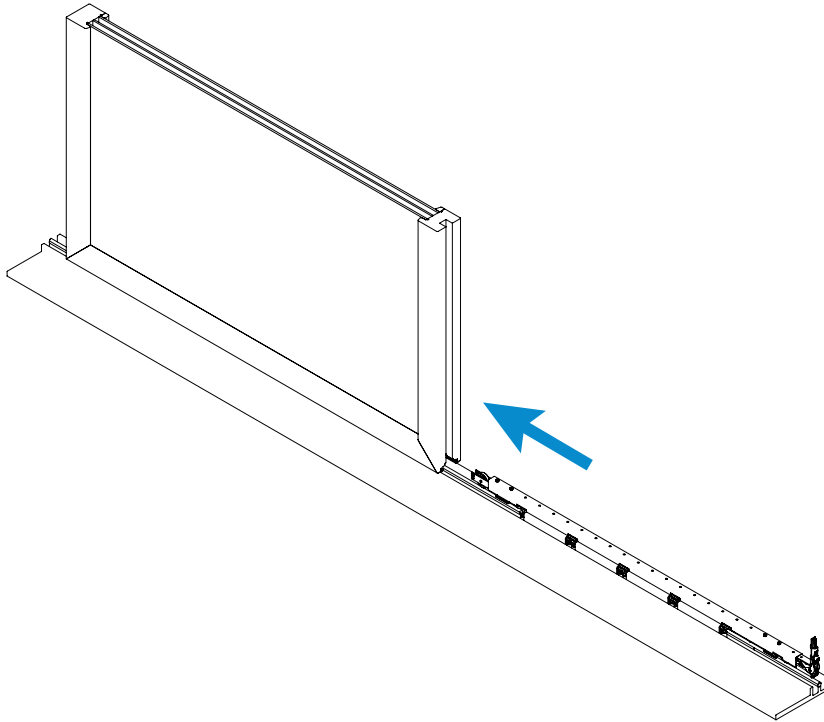

- 5** Lower the sash until it comes to rest and fix the kit with the side screws.

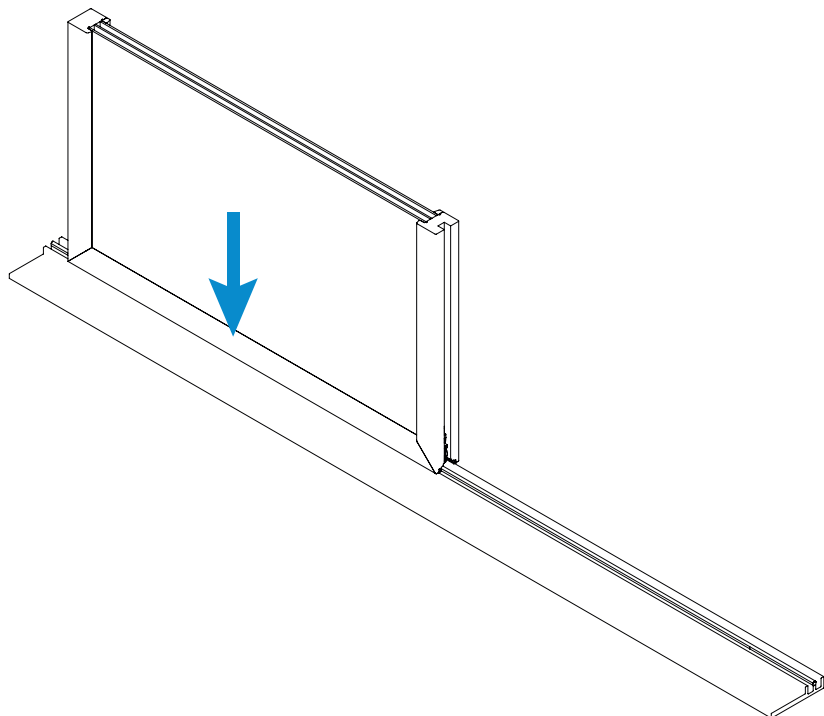

Ironlev threshold for Lift-and-Slide system

The Ironlev threshold is designed to allow the integration of “Medium” slider into a Lift-and-Slide system.





The structure material with a high thermal break allows perfect insulation and easy integration into the building structure.

The surface covering is available in multiple materials and finishes, ensuring maximum aesthetic performance.

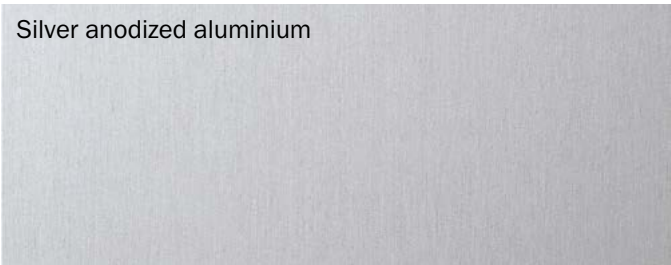
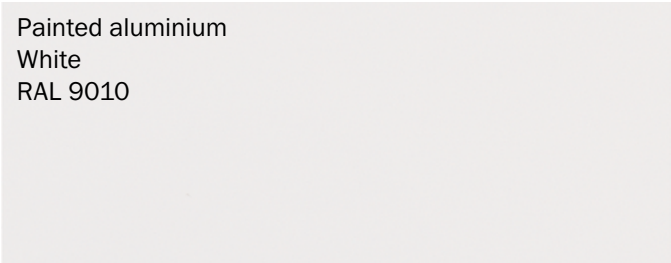
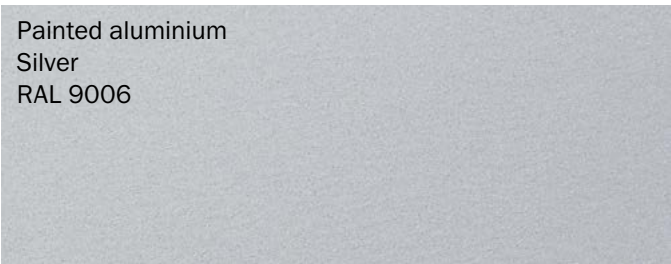
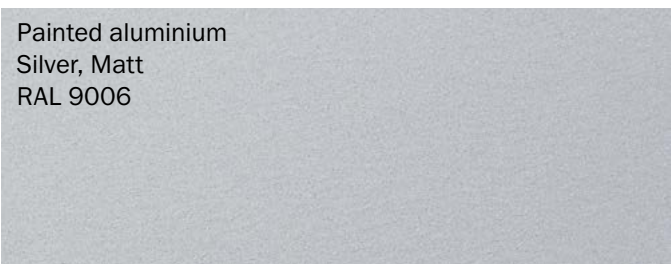
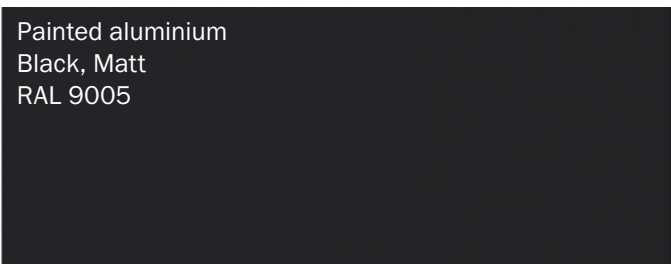

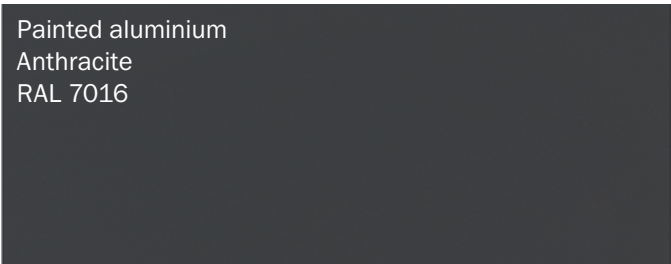
AESTHETICAL FINISHES

MATERIAL AND FINISHES	LENGTH	CODE	PACKAGE QTY.
 Silver anodized aluminium	6m	100675	1 pce
	4m	100686	1 pce
 Painted aluminium White RAL 9010	6m	100681	1 pce
	4m	100687	1 pce
 Painted aluminium Silver RAL 9006	6m	100682	1 pce
	4m	100688	1 pce
 Painted aluminium Silver, Matt RAL 9006	6m	100683	1 pce
	4m	100689	1 pce
 Painted aluminium Black, Matt RAL 9005	6m	100684	1 pce
	4m	100690	1 pce

MATERIAL AND FINISHES	LENGTH	CODE	PACKAGE QTY.
 Painted aluminium Anthracite RAL 7016	6m	100685	1 pce
	4m	100691	1 pce
 SB stainless steel	6m	100676	1 pce
	4m	100692	1 pce
 Natural brass	6m	100677	1 pce
	4m	100693	1 pce
 Burnished brass	6m	100678	1 pce
	4m	100694	1 pce

Assembly instructions

IRONLEV THRESHOLD

- 1 After cutting the threshold to the desired size, position the end caps and fix them by using 5x60 screws. Apply silicone to the lower surface of the cap to ensure a correct seal.

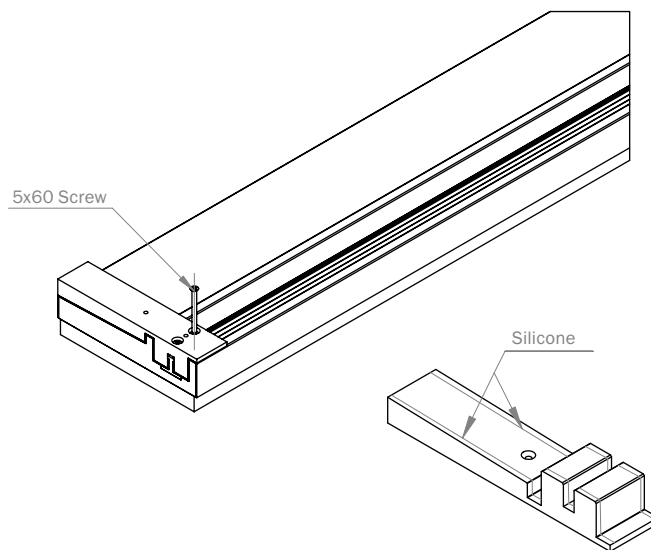

- 2 Fix the two lateral uprights with 6x135 screws.

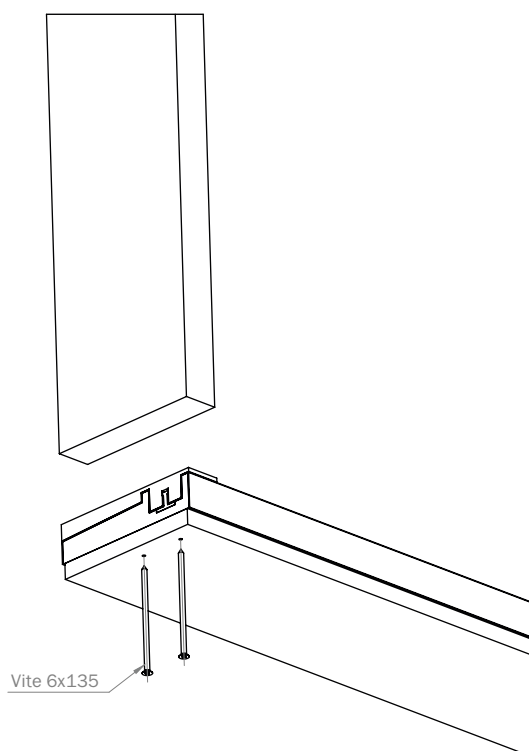

- 3** Fix the d12 mm rail by using the appropriate structural double-sided adhesive applied on the plastic support profile. Use the centering tool for the correct positioning of the upper rail.

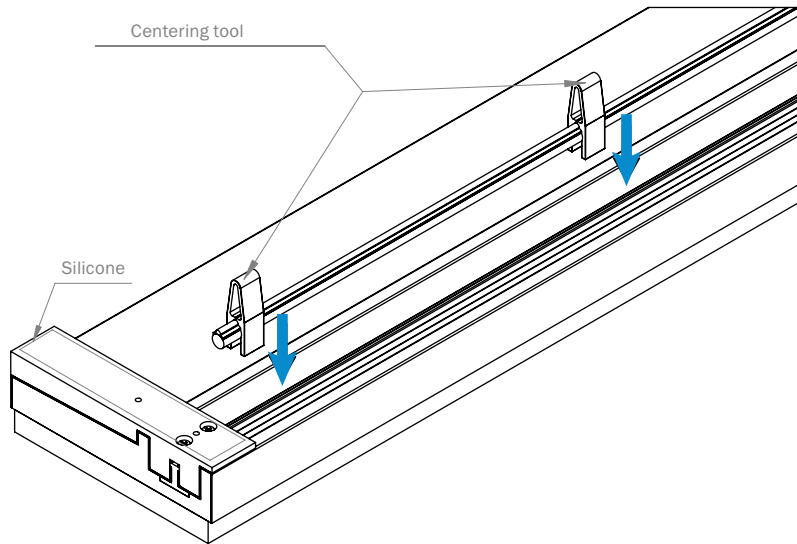

- 4** Apply the central cap and the fixed door support profile and fix the elements by using screws. Apply silicone to the bottom surface of the cap to ensure a correct seal.

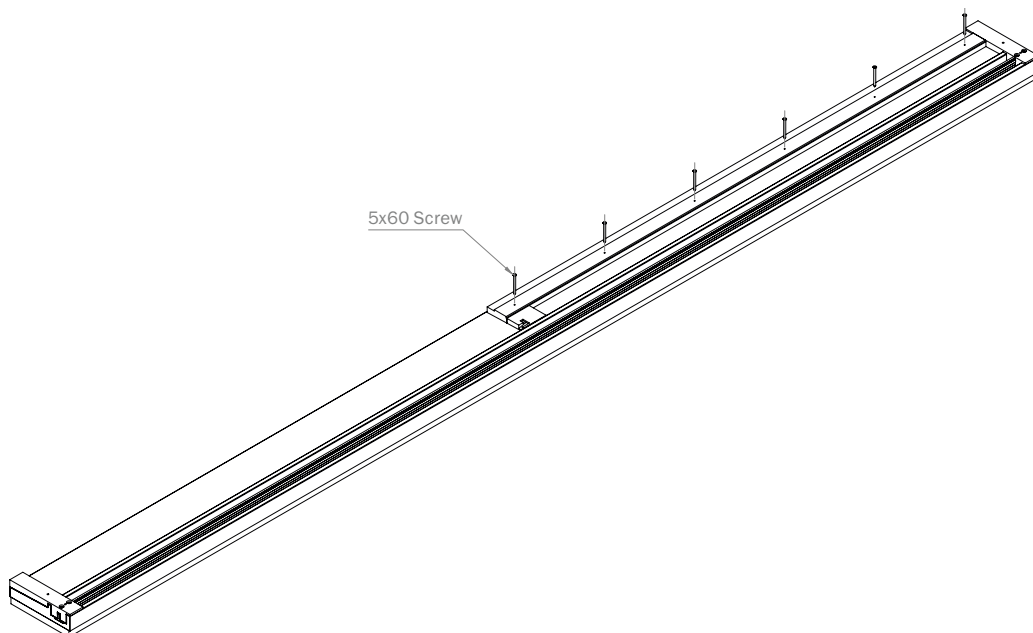

Link

Slim

Technical manual



Assembly instructions



Test certificates



Medium

Technical manual



Assembly instructions



Test certificates



ironlev

Ironlev One Srl
Via Luigi Galvani, 6/A
31027 Spresiano (TV)
Italy