

www.abcvalve.com

Your Worldwide
Reliable Supplier



WEARSTAR

ABCvalve

ABC valve in Wear Resistance

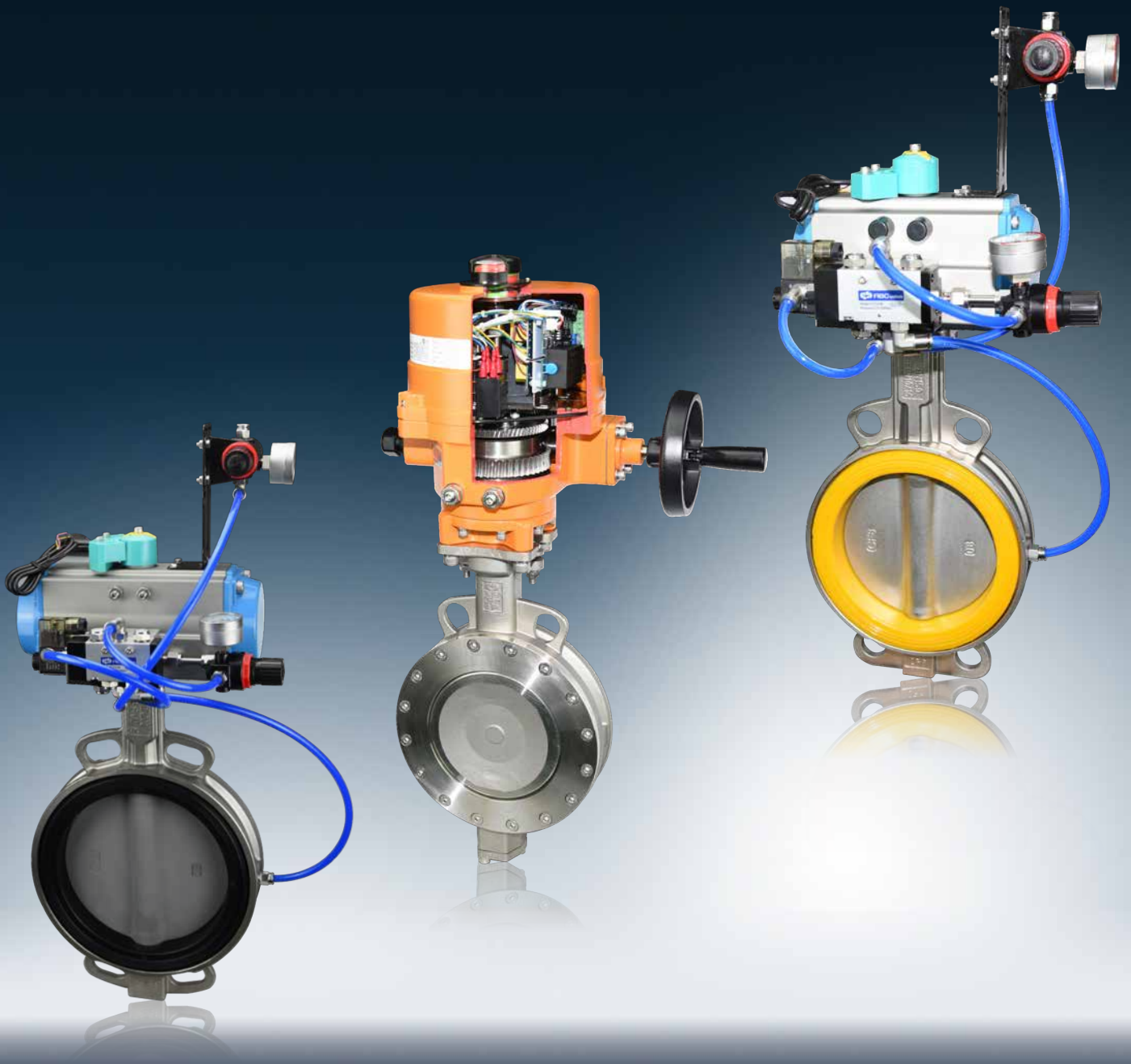

About ABC

ABC VALVE is an international company headquartered in Singapore and started from Automatic Butterfly valve Control. As the product is increasingly recognized by more and more customers, we have now 2 producing factories and 6 production lines in China. We have also producing factories in South Africa and Turkey, Warehouse in Singapore, Sweden, Netherlands, Denmark, American and distributors in many countries of world.

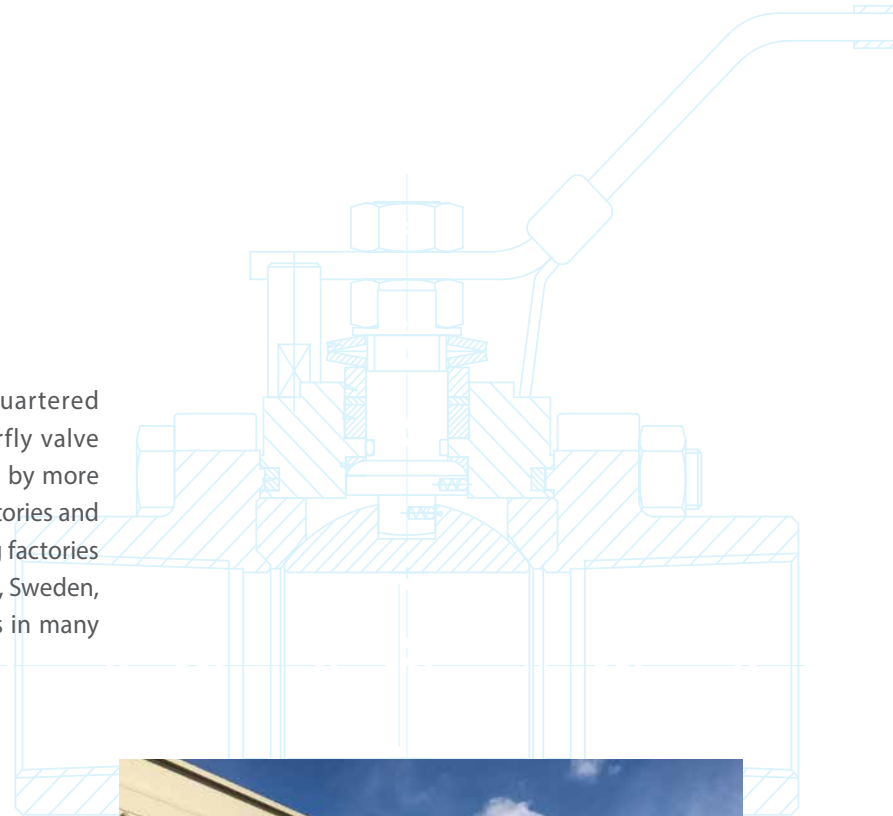

The specialty products are Wear resistant butterfly valve, High performance butterfly valve, Triple eccentric butterfly valve, Inflatable seat butterfly valve, Ceramic butterfly valve, PTFE lined butterfly valve, AWWA butterfly valve; High performance ball valve, Inflatable seat ball valve, Ceramic ball valve, PTFE lined ball valve, Segment ball valve, Dome valve, Semi Dome valve; High cycle thin swing check valve, Tilting disc check valve; Discharge control valve, Tank bottom valve, Star type discharge valve, Diverter valve; Modulating valve, Steam traps. Manufacturing systems and products are certified by ISO9001, BV Marine, PED CE, FDA, DVGW, WRAS, KTW, Fire Test Certification. These create good conditions for us to service customers worldwide with ABC high quality products.

With unique patent structures on wear resistance, reliable sealing, accurate control and modulating, special attention on user's experience from design, Emphasizing the interchangeability of valve parts, the valves are particularly preferred in battery materials, silicon powder, paints production, slurries and the more fields with high requirements for wear resistance, safe isolation and corrosion resistance. The valves are also widely well used in pharmaceuticals, food and beverage, automotive industry, shipbuilding, electronics, nuclear power, air separation, new materials, membrane technology, petroleum, chemical industry, thermal industry, papermaking and other fields.

The mission of ours is Making fluid control easier. With high attention on long term cooperation, ABC always work together with you!



ABC valve in High Temperature

Thanks to worldwide customer advice and technical accumulation, ABC valve has excellent user experience.



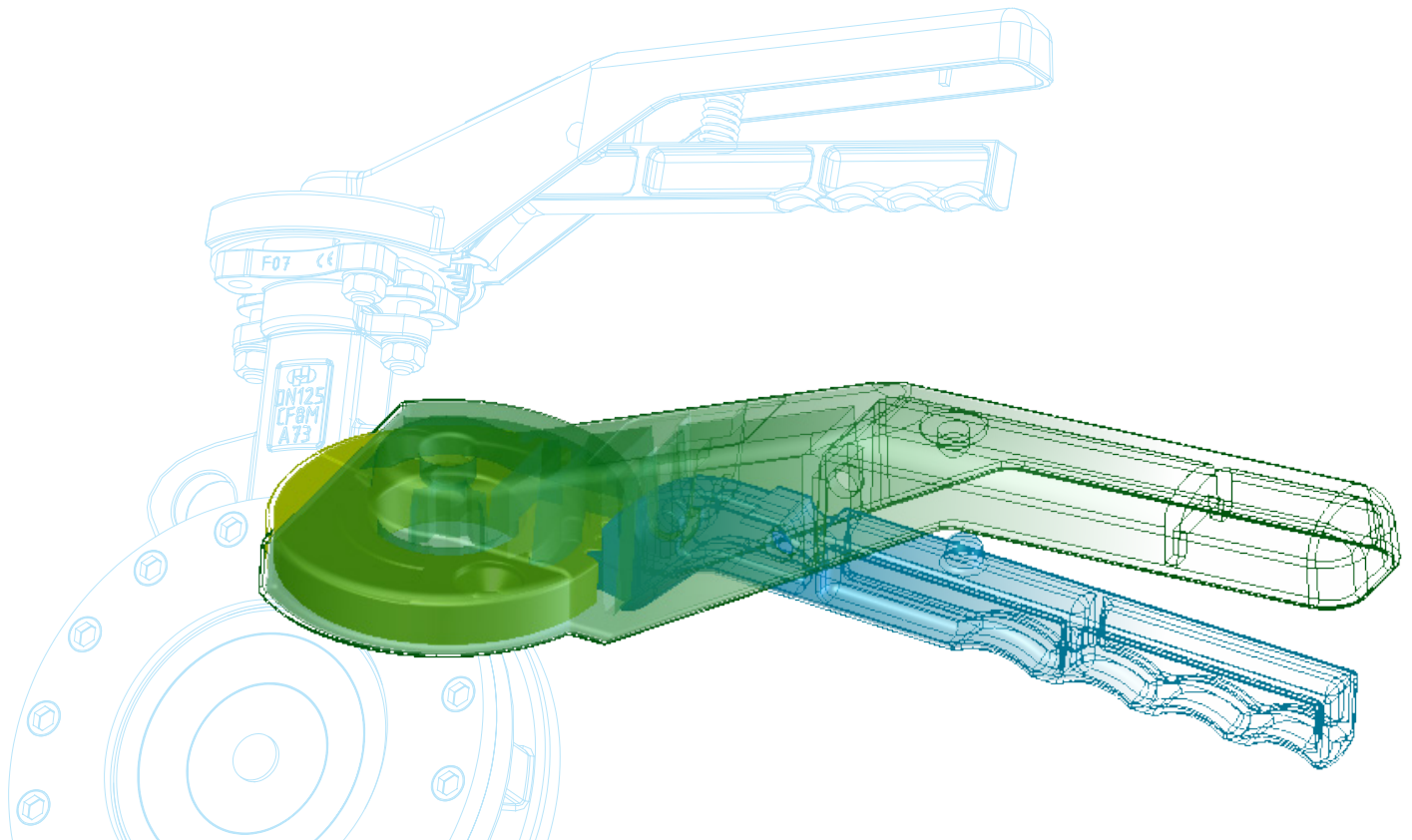

Each series of products developed by ABC valve is to solve the problems of similar others in the market, and to let users have a better experience. ABC lined butterfly valve has its rubber seat and PTFE seat interchangeable each other, as causes leap in butterfly valve production, storage and maintenance. ABC eccentric butterfly valve has its seat and packing self sealing in both direction even with metal seat, as multiplies the valve life time and brings revolution in application. Improvements of supersonic spray welding technology and welding alloy composition keep ABC metal seat ball valve working ability greatly enhanced. ABC standard valve torque, Kv and sealing life

make ABC valve a synonym of energy-saving valve. With more attention on safety, ABC valve will give you different experience.



Wax injection

Valve ball polishing

Stem ready

PTFE moulding

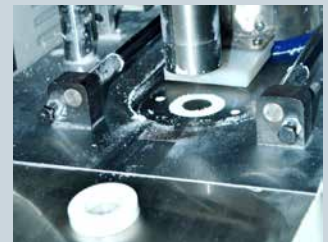

ABC Valve in Semiconductor Production Cleaning System



Material inspection

ABC strictly controls the production process and results from casting, carries out spectral analysis, metallographic analysis, tensile and impact tests on metal materials before and after furnace, strictly controls the heat treatment process, and batches of sealing materials such as rubber are tested from mixing to verify the properties of materials.

Raw material



Metallographic specimen



Tensile test rod



Sulfur characteristic specimen



Tensile test piece



Tear strength piece



Wear test block



Compressing test block



Dimension inspection

ABC uses advanced and effective three-coordinate measuring instrument, pendulum instrument, high-precision platform, special measuring tools and other professional equipment to measure the dimensions of valve components, to ensure that the dimensions meet the design requirements.

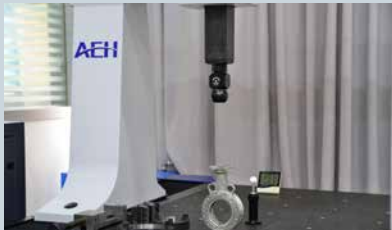

Flange surface inspection

ABC uses Professional Profiler to measure the sealing surface of flange to ensure that gasket and flange are pressed tightly and there is no leakage passage.

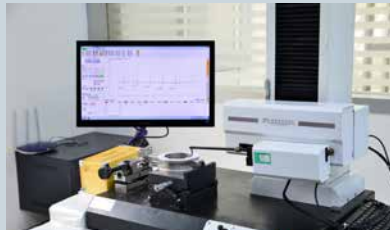

Smoothness test

ABC uses a quantitative roughness meter to measure the smoothness of materials and machined surfaces to ensure that the smoothness of parts meets the requirements of pipelines and sealing on reducing wear.



Inspection of spray thickness

ABC uses ultrasonic thickness gauge to measure spraying thickness and professional methods such as impact and pull out test to evaluate spraying quality.



Torque testing

ABC uses professional electronic digital torque meter to record the torque of each valve, and has buzzing overset to ensure that each valve meets the torque range before leaving the factory.



Pressure test

ABC carries out shell strength test of 1.5 times working pressure and seal test of 1.1 times working pressure on each valve to ensure that the valve is safe and no leakage.



Life testing

ABC carries out life sampling test for each batch of valves to ensure no accidental occurrence.

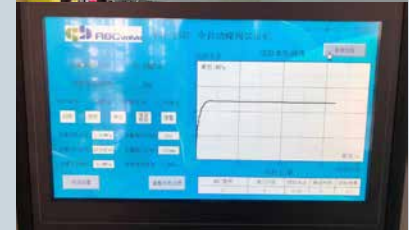

ABC valve in Water Treatment



A65 AWWA Butterfly Valve Design Features

High strength S30400 for Class150B and S17400 for Class250B and Class300. Shaft diameter and design according to AWWA C504

Adjustable packing gland.

Self-lubricated teflon-lined, fiberglass-backed bearings provide low friction service without grease lubrication.

High precision Stainless steel seat.

Ductile iron body thickness according to AWWA C504, excellent even for underground long life using.

Stainless Steel Taper Pins with lock nut and o-ring seal utilize tangential forces of the taper pin and lock nut to provide strong driving between stem and disc.

Factory-set thrust bearing assures proper centering of valve disc.

Specially formulated elastomers that are reinforced and capable of handling localized velocities of over 200 ft. /sec. and withstanding pressure of 50bar.



ABC Technique and Quality



A23, A24 Butterfly Valve Design Features

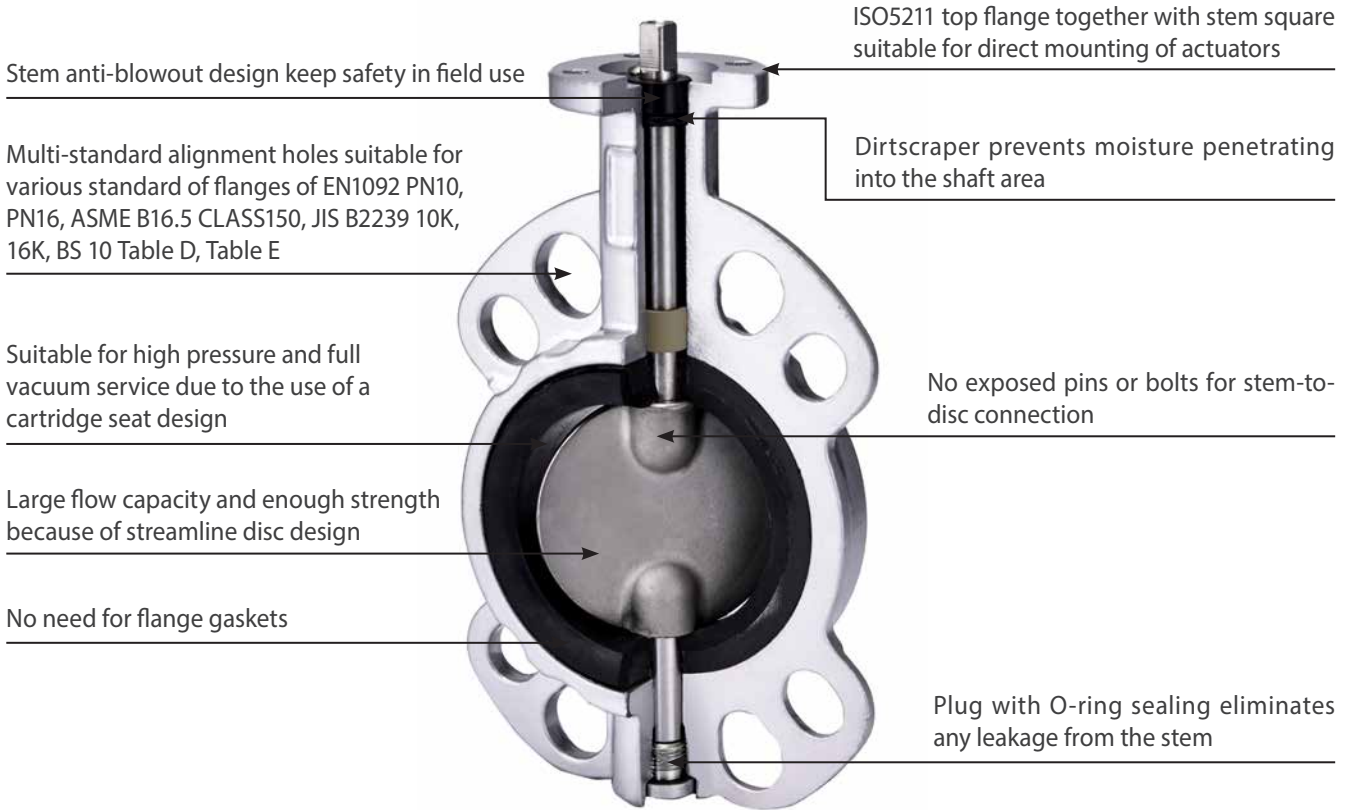

C14 Thin Wafer Check Valve Design Features

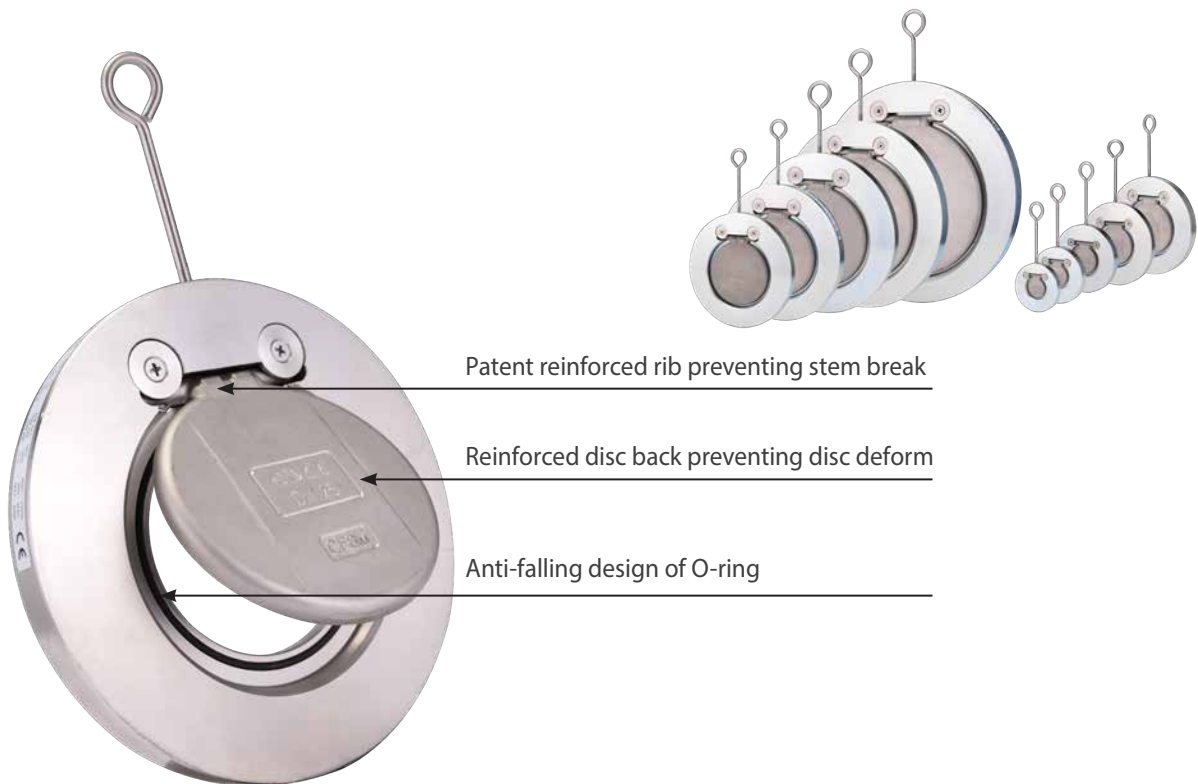

ABC valve in Battery material

ABC Y2 star type discharge valves are designed for distribution of materials under gravity, pressure and vacuum conditions. They are suitable for metering a wide range of dry solids, granular, pelleted and powdered type materials from the outlets of the silos, hopper, cyclones, mixers, weighers etc.

ABC Y2 star type discharge valves are also specially used in Lithium Battery Industry because of wear-resistant construction and stem sealing design. The valves also feature excellent isolation between valve metal body and medium, high strength Nylon or Ceramic are used as isolation materials for avoiding medium contacting with metal. Such kind isolation is very important to keep Lithium Battery materials safe.



A31, A32 Wear Resistant Butterfly Valve Design Features

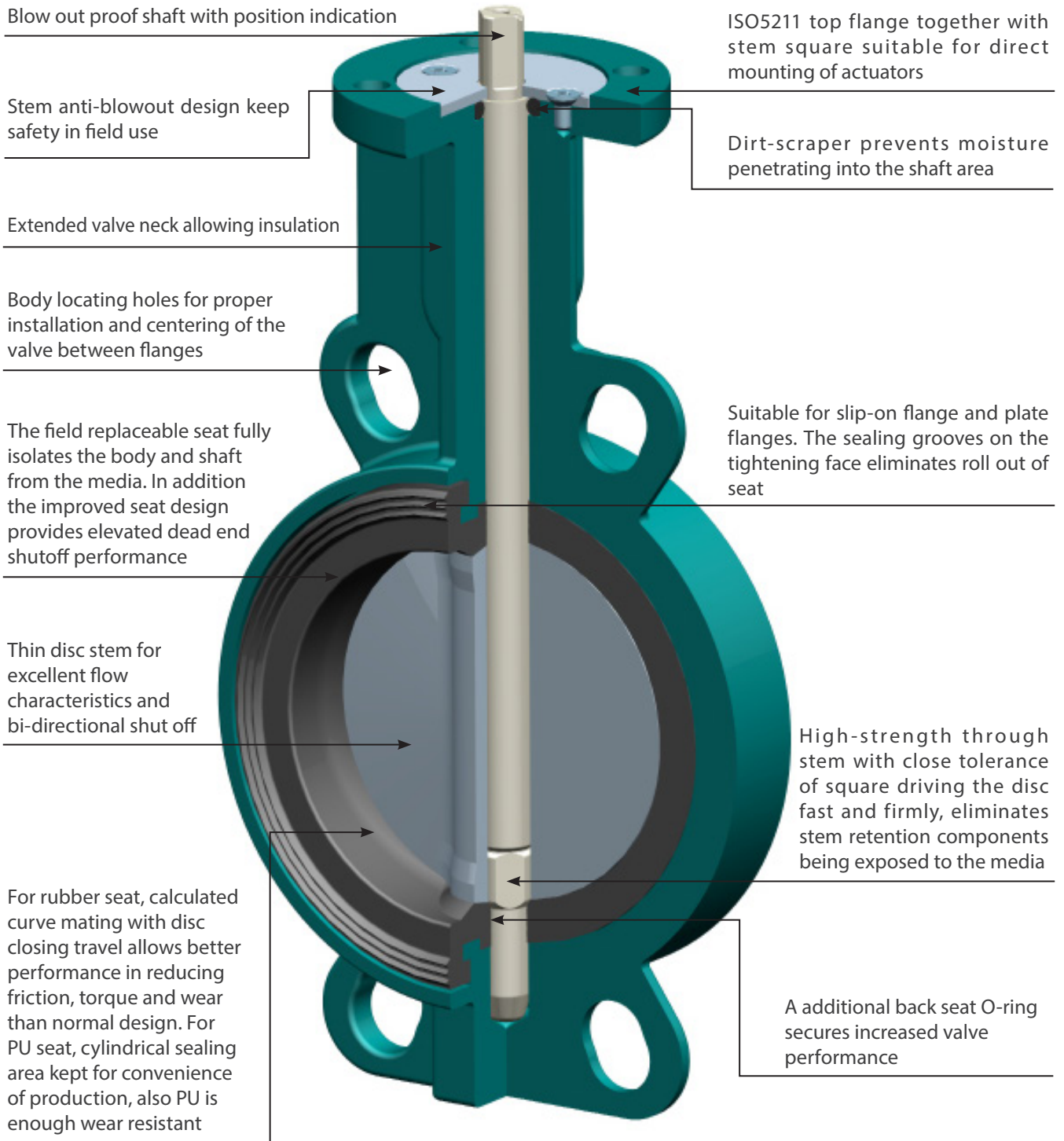

Battery material High Temperature & High Wear-resistance ABC Valve



A73, A74 High Performance Butterfly Valve Design Features

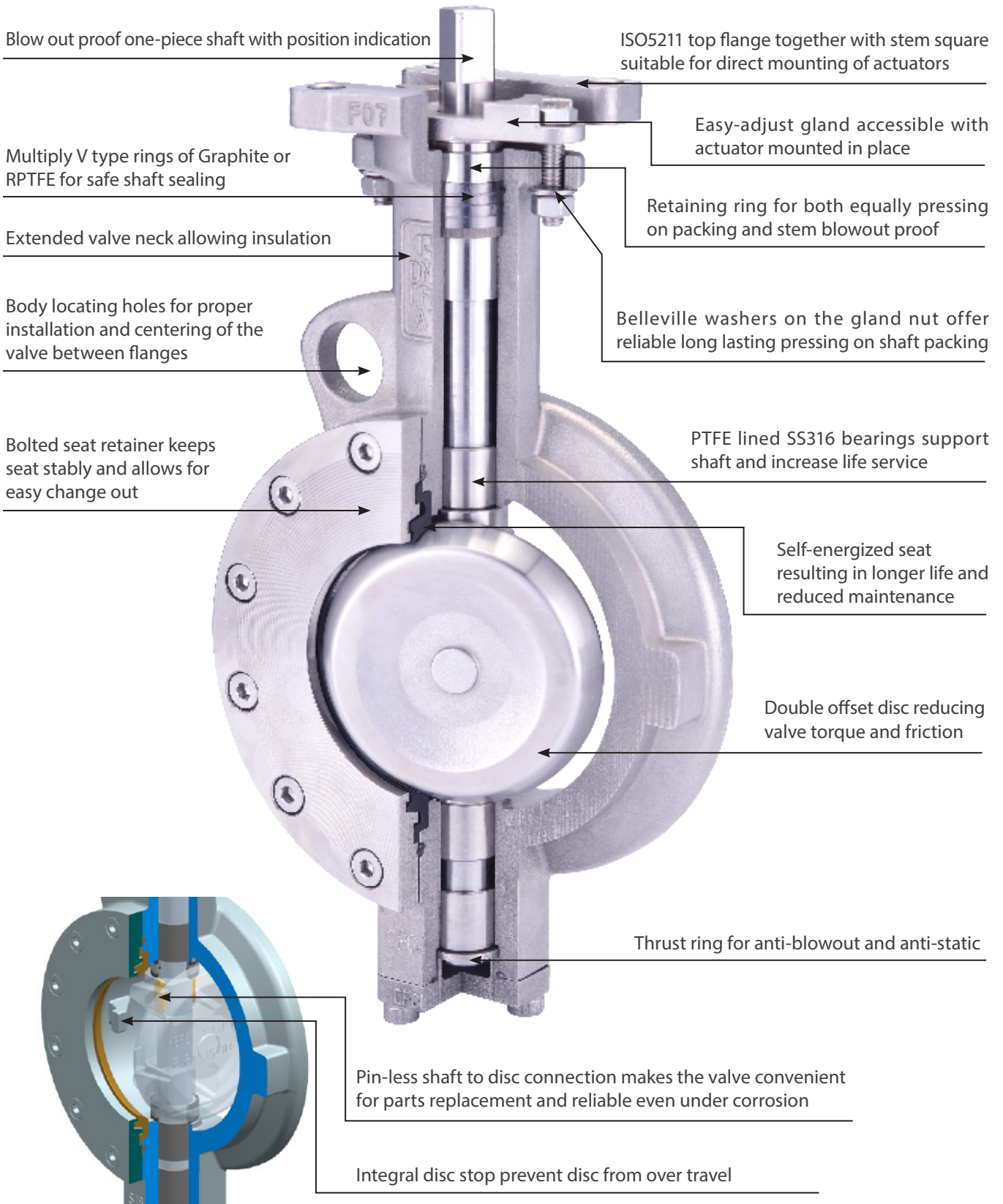

A31INF Inflatable Butterfly Valve Design Features

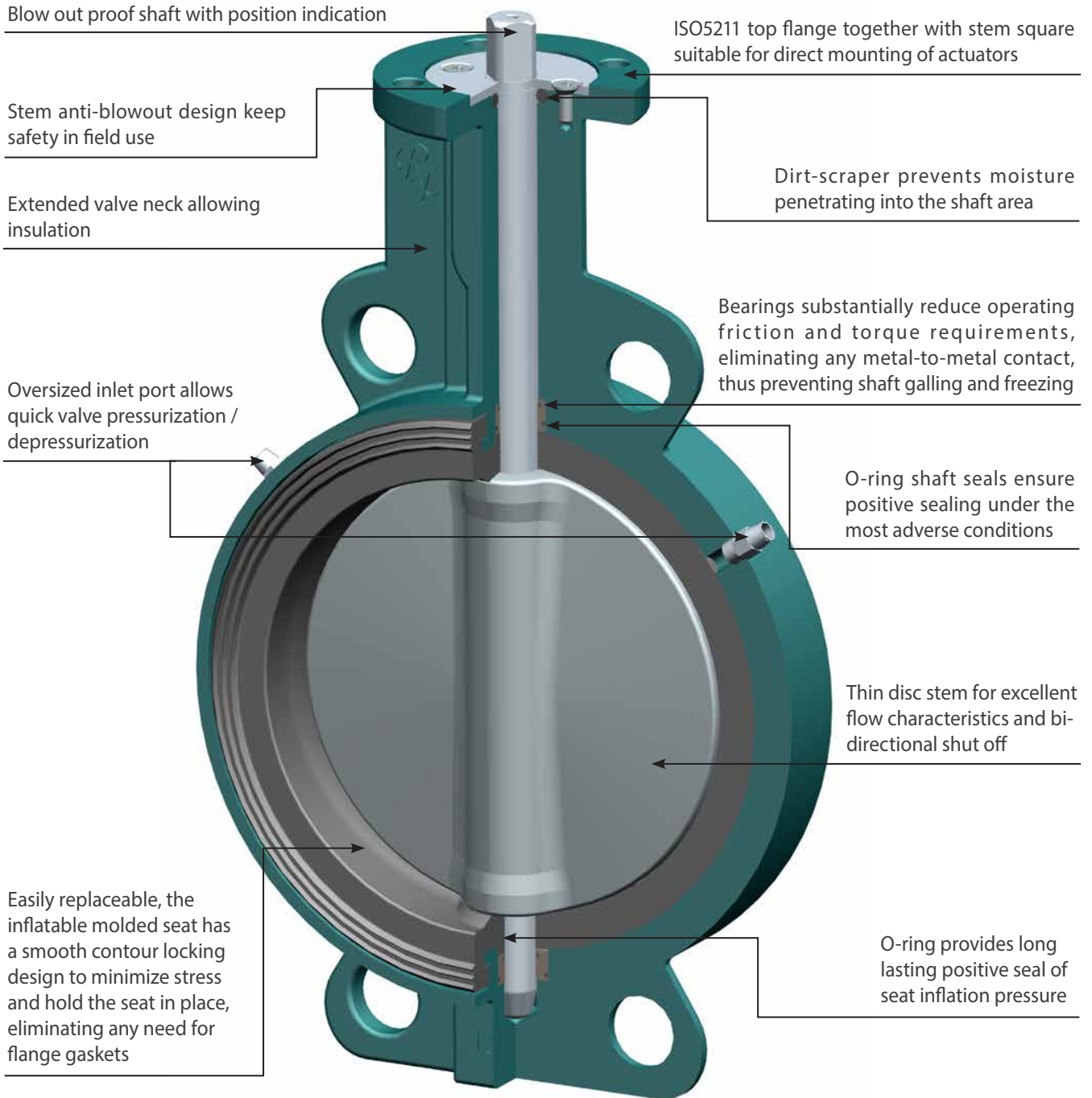

A31INF Inflatable Butterfly Valve Seat Principle

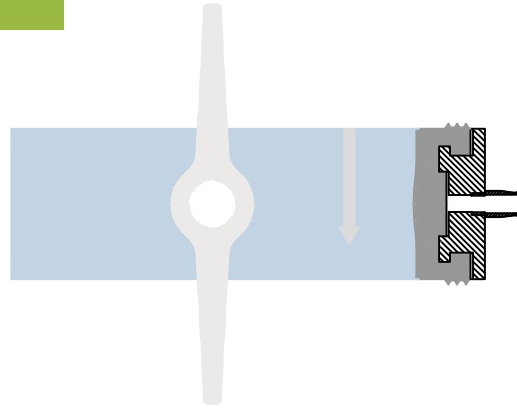

When the disc opening, the valve seat relax,
medium fully flow through.

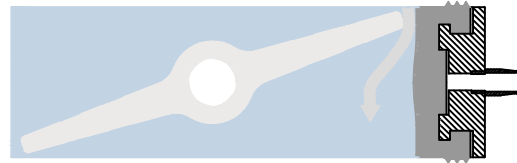

When the disc turning to the closed position, the
valve seat remains relaxed, small friction between the
disc and seat, small amount medium flow through.

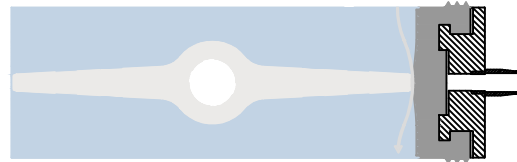

When the disc closed, the valve seat remains relaxed
in the closing moment, small friction between the
disc and seat, little medium flow through.

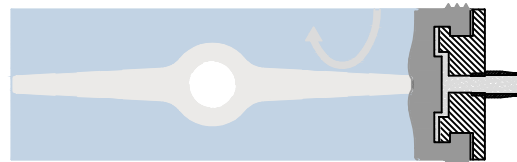

After the disc closed, the air room between the seat
and the body is inflated, the seat shrinks toward the
disc, providing a tighter seal between the seat and
the disc.

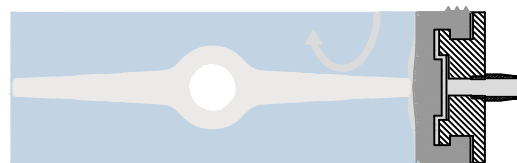

The disc is closed and the seat will not release until
receiving the signal of disc opening.

A23 Wafer Concentric Butterfly Valves



MATERIALS

Body	ASTM A536 65-45-12, WCB, CF8M
Disc	ASTM A536 65-45-12 Nylon coated, CF8, CF8M, 2507, 1.4462
Seat	EPDM, NBR, FPM
Stem	SS420, SS431

TECHNICAL DATA

Connection	Wafer
Nominal Diameter	DN50-DN2000
Operating Pressure	16bar for DN50-DN300, 10bar for DN350-DN2000
Flange Standard	DN50-DN300: EN1092 PN10/16, ASME B16.5 Class150, JIS B2239 10K/16K, BS10 Table D/E
	DN350-DN2000: EN1092 PN10/16, ASME B16.5 Class150, BS10 Table D/E
Face To Face	EN558 Series 20, API 609 Table 1
Top Flange	ISO 5211
Tightness Check	ISO 5208 Category 3, API 598 Table 5
Temperature Range	-40° C to + 180° C (Depending on pressure, medium and material)
Operation	Hand lever, gear box, pneumatic actuator, electric actuator

A24 Lug Concentric Butterfly Valves



MATERIALS

Body	ASTM A536 65-45-12, WCB, CF8M
Disc	ASTM A536 65-45-12 Nylon coated, CF8, CF8M, 2507, 1.4462
Seat	EPDM, NBR, FPM
Stem	SS420, SS431

TECHNICAL DATA

Connection	Lug
Nominal Diameter	DN50-DN2000
Operating Pressure	16bar for DN50-DN300, 10bar for DN350-DN2000
Flange Standard	DN50-DN300: EN1092 PN10/16, ASME B16.5 Class150, JIS B2239 10K/16K, BS10 Table D/E
	DN350-DN2000: EN1092 PN10/16, ASME B16.5 Class150, BS10 Table D/E
Face To Face	EN558 Series 20, API 609 Table 1
Top Flange	ISO 5211
Tightness Check	ISO 5208 Category 3, API 598 Table 5
Temperature Range	-40° C to + 180° C (Depending on pressure, medium and material)
Operation	Hand lever, gear box, pneumatic actuator, electric actuator

A31 Wafer Wear Resistant Butterfly Valves



MATERIALS

Body	ASTM A536 65-45-12, CF8, CF8M, nylon,
Disc	ASTM A536 65-45-12 Nickle plated, CF8, CF8M, 2507, 1.4462, CF8 Tungsten coated, CF8 Halar coated nylon,aluminum
Seat	EPDM, NBR, FPM, HNBR
Stem	SS420, SS431

TECHNICAL DATA

Connection	Wafer
Nominal diameter	DN50-DN2000
Operating pressure	16bar for DN50-DN300, 10bar for DN350-DN2000
Flange standard	EN1092 PN10/16, ASME B16.5 Class150
Face to face	EN558 Series 20, API 609 Table 1
Top flange	ISO 5211
Tightness check	ISO 5208 Category 3, API 598 Table 5
Temperature range	-40° C to + 260° C (Depending on pressure, medium and material)
Operation	Hand lever, Gear box, Pneumatic actuator, Electric actuator

A32 Lug Wear Resistant Butterfly Valves



MATERIALS

Body	ASTM A536 65-45-12, CF8, CF8M
Disc	ASTM A536 65-45-12 Nickle plated, CF8, CF8M, 2507, 1.4462, CF8 Tungsten coated, CF8 Halar coated
Seat	EPDM, NBR, FPM, HNBR
Stem	SS420, SS431

TECHNICAL DATA

Connection	Lug
Nominal diameter	DN50-DN2000
Operating pressure	16bar for DN50-DN300, 10bar for DN350-DN2000
Flange standard	EN1092 PN10/16, ASME B16.5 Class150
Face to face	EN558 Series 20, API 609 Table 1
Top flange	ISO 5211
Tightness check	ISO 5208 Category 3, API 598 Table 5
Temperature range	-40° C to + 260° C (Depending on pressure, medium and material)
Operation	Hand lever, Gear box, Pneumatic actuator, Electric actuator

A35T Wafer PTFE Lined Butterfly Valve



MATERIALS

Body CF8, CF8M
 Disc CF8 with PTFE lined,
 CF8M with PTFE lined,
 CF8 with tungsten coated
 CF8 with ceramic coated
 Seat PTFE
 shaft SS431

TECHNICAL DATA

Connection Wafer
 Nominal diameter DN50-DN600
 Operating pressure Full vacuum~10bar
 Flange standard EN1092 PN10/16, ASME B16.5 Class150
 Face to face EN558 Series 20, API 609 Table 1
 Top flange ISO 5211
 Tightness check ISO 5208 Category 3, API 598 Table 5
 Temperature range -40° C to + 180° C
 Operation hand lever , gear box, pneumatic actuator
 electric actuator

A35 2PC Body Wafer PTFE Lined Butterfly Valve



MATERIALS

Body ASTM A536
 65-45-12, CF8, CF8M
 Disc CF8, CF8M, CF8+PTFE
 CF8M+PTFE
 CF8 with tungsten coated
 CF8 with ceramic coated
 Seat PTFE
 Shaft Integrated with valve disc

TECHNICAL DATA

Connection Wafer
 Nominal diameter DN50-DN600
 Operating pressure Full vacuum~16bar
 Flange standard EN1092 PN10/16, ASME B16.5 Class150
 Face to face EN558 Series 20, API 609 Table 1
 Top flange ISO 5211
 Tightness check ISO 5208 Category 3, API 598 Table 5
 Temperature range -40° C to + 180° C
 Operation hand lever , gear box, pneumatic actuator
 electric actuator

A36 2PC Body Lug PTFE Lined Butterfly Valve



MATERIALS

Body ASTM A536
 65-45-12, CF8, CF8M
 Disc CF8, CF8M, CF8+PTFE
 CF8M+PTFE
 CF8 with tungsten coated
 CF8 with ceramic coated
 Seat PTFE
 Shaft Integrated with valve disc

TECHNICAL DATA

Connection Lug
 Nominal diameter DN50-DN600
 Operating pressure Full vacuum~16bar
 Flange standard EN1092 PN10/16, ASME B16.5 Class150
 Face to face EN558 Series 20, API 609 Table 1
 Top flange ISO 5211
 Tightness check ISO 5208 Category 3, API 598 Table 5
 Temperature range -40° C to + 180° C
 Operation hand lever , gear box, pneumatic actuator
 electric actuator

A31 INF Inflatable Butterfly Valves

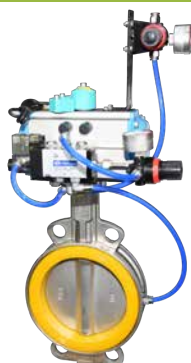

MATERIALS

Body ASTM A536 65-45-12, CF8,
 CF8M
 Disc ASTM A536 65-45-12
 Nickle plated, CF8, CF8M,
 CF8 Tungsten coated, CF8
 Halar coated
 Seat EPDM, NBR, FPM, HNBR
 Stem SS420, SS431

TECHNICAL DATA

Connection Wafer
 Nominal diameter DN50-DN600
 Operating pressure Full vacuum~10bar
 Flange standard EN1092 PN10/16, ASME B16.5 Class150
 Face to face EN558 Series 20, API 609 Table 1
 Top flange ISO 5211
 Tightness check ISO 5208 Category 3, API 598 Table 5
 Temperature range -40° C to + 260° C (Depending on pressure,
 medium and material)
 Operation Pneumatic module

Y2 Star type Discharge Valves



MATERIALS

Body	P200 high strength & high wear-resistance nylon, PU Polyurethane, SS304, SS304 with ceramic lining, TA2
Rotor	P200 high strength & high wear-resistance nylon, PU Polyurethane, SS304, ceramic, TA2
Seal	Lip seal, Mechanical seal, Inflatable seal

TECHNICAL DATA

Connection Flange	PN10,PN16
Nominal diameter	DN150-DN300
Face to face	As the drawing
Rotor Sealing	Air-rate type, Air-lock type
Temperature	P200 : -29°C to +100°C PU : -20°C to +90°C Ceramic : -29°C to +200°C SS304 : -29°C to +300°C
Operation	Fixed-frequency motor Variable frequency motor, chain wheel, belt

A73INF Dome Type Butterfly Valves



MATERIALS

Body	CF8, CF8M CF8 with Halar or PTFE coating CF8 with tungsten coating CF8+Ceramic
Disc	CF8, CF8M CF8 with Halar or PTFE coating CF8 with tungsten coating CF8+Ceramic
Seat	EPDM, H160, F260
Stem	SS304, SS316L

TECHNICAL DATA

Connection	Wafer
Nominal diameter	DN50-DN300
Operating pressure	10bar
Flange standard	EN1092 PN10/16
Face to face	As the drawing
Top flange	ISO 5211
Pressure test	ISO 5208
Temperature range	-29° C to + 360° C (Depending on pressure, medium and material)
Operation	pneumatic

A45 Double Flanged Butterfly Valves



MATERIALS

Body	ASTM A536 65-45-12, WCB, CF8M bonded with NBR or EPDM
Disc	ASTM A536 65-45-12, Nylon coated, CF8, CF8M, 2507, 1.4462
Stem	SS420, SS431

TECHNICAL DATA

Connection	Double flange
Nominal diameter	DN50-DN2200
Operating pressure	16bar for DN50-DN300, 10bar for DN350-DN2200
Flange standard	EN1092 PN10/16, ASME B16.5 Class150
Face to face	EN558 Series 13
Top flange	ISO 5211
Tightness check	ISO 5208 Category 3, API 598 Table 5
Temperature range	-40° C to + 130° C (Depending on pressure, medium and material)
Operation	Hand lever, gear box, pneumatic actuator, electric actuator

A65 AWWA Flanged Butterfly Valves



MATERIALS

Body	ASTM A536 65-45-12, CF8, CF8M, 2507,
Disc	ASTM A536 65-45-12, CF8, CF8M, 2507, 1.4462
Seat	EPDM, NBR,HNBR
Stem	SS30400, S17400

TECHNICAL DATA

Connection	Double flange
Nominal diameter	DN200-DN2000
Operating pressure	10bar~50bar
Flange standard	EN1092 PN10/16/25/40, ASME B16.5 Class150/Class300
Face to face	AWWA C504, ISO5752 Series 13, Series 14
Top flange	ISO 5211
Tightness check	AWWA C504, ISO5208 Category 3
Temperature range	-29° C to + 260° C (Depending on pressure, medium and material)
Body protection	Epoxy coating, heavy anti-corrosion coating
Operation	Gear box, Pneumatic actuator, Electric actuator

A73 Wafer Double Offset Butterfly Valves



MATERIALS

Body	WCB	CF8M
Disc	CF8*	CF8M*
Seat	RPTFE, SS316+RPTFE, SS316 P287	
Shaft	17-4 PHSS,1.4462	

TECHNICAL DATA

Connection	Wafer
Size	3"-24"
Pressure	Class150,Class300
Flange standard	ASME B16.5 Class150, Class300; EN1092 PN16, PN25, PN40
Face to face	API 609 Category B valve Wafer
Pressure test	API 598
Temperature	PTFE seat - 40° C to +287° C
Operator	Lever, Gear box, Pneumatic actuator, Electric actuator

A74 Lug Double Offset Butterfly Valves



MATERIALS

Body	WCB	CF8M
Disc	CF8*	CF8M*
Seat	RPTFE, SS316+RPTFE, SS316	
Shaft	17-4 PHSS,1.4462	

TECHNICAL DATA

Connection	Lug
Size	3"-24"
Pressure	Class150,Class300
Flange standard	ASME B16.5 Class150, Class300; EN1092 PN16, PN25, PN40
Face to face	API 609 Category B valve Lug
Pressure test	API 598
Temperature	PTFE seat - 40° C to +287° C
Operator	Lever, Gear box, Pneumatic actuator, Electric actuator

A75 Flanged Double Offset Butterfly Valves



MATERIALS

Body	WCB, CF8,CF8M
Disc	WCB,CF8,CF8M
Seat	PTFE,RPTFE,P287,
Shaft	17-4 PHSS

TECHNICAL DATA

Connection	Double flange
Size	DN50-DN1600
Pressure	Full vacuum-50bar
Flange standard	EN1092 PN10/16,PN25,PN40 ASME B16.5 Class150,Class300
Face to face	ISO5752, ASME B16.10, API 609,double flange short pattern
Top flange	ISO 5211
Pressure test	ISO 5208 Category 3, API 598 Table 5
Temperature	-40° C to + 287° C
Operator	Lever,Gear box,Pneumatic actuator,Electric actuator

A83 Wafer Triple Offset Butterfly Valves



MATERIALS

Body	WCB,CF8,CF8M
Disc	WCB,CF8,CF8M
Seat	Metal seat
Shaft	17-4PHSS

TECHNICAL DATA

Connection	Wafer
Size	DN50-DN1200
Pressure	Full vacuum-50bar
Flange standard	EN1092 PN10/16,PN25,PN40 ASME B16.5 Class150,Class300
Face to face	API 609 category B valve wafer
Top flange	ISO 5211
Pressure test	API 598,
Temperature	-40° C to + 500° C
Operator	Lever,Gear box,Pneumatic actuator,Electric actuator

A84 Lug Triple Offset Butterfly Valves



MATERIALS

Body	WCB,CF8,CF8M
Disc	WCB,CF8,CF8M
Seat	Metal seat
Shaft	17-4PHSS

TECHNICAL DATA

Connection	Lug
Size	DN50-DN1200
Pressure	Full vacuum-50bar
Flange standard	EN1092 PN10/16,PN25,PN40 ASME B16.5 Class150,Class300
Face to face	API 609 category B valve wafer
Top flange	ISO 5211
Pressure test	API 598,
Temperature	-40° C to + 500° C
Operator	Lever,Gear box,Pneumatic actuator,Electric actuator

B10 Unibody Threaded Ball Valves



MATERIALS

Body	CF8
Ball	SS304
Seat	PTFE
Stem	SS304

TECHNICAL DATA

Connection	Threaded BSPP, Alternative NPT, BSPT
Nominal diameter	1/4"-2"
Pressure rating	PN63
Temperature range	-20° C to + 200° C
Operation	Hand lever with lockable device

B20 2PC Threaded Ball Valves



MATERIALS

Body	CF8
Ball	SS304
Seat	PTFE
Stem	SS304

TECHNICAL DATA

Connection	Threaded BSPP, Alternative NPT, BSPT
Nominal diameter	1/4"-4"
Pressure rating	PN63
Temperature range	-20° C to + 200° C
Operation	Hand lever with lockable device

B33 High Performance 3PC Ball Valves



MATERIALS

Body	WCB,CF8,CF8M, CF3M,2507,904L
Ball	SS304L,SS316L, 2507,904L
Seat	PTFE,RPTFE,P287
Stem	SS304L,SS316L, 2507,904L

TECHNICAL DATA

Connection	Threaded ,Butt weld , Somet weld
Nominal diameter	DN15-DN50
Pressure rating	1500PSI
threaded standard	BSPP,ISO228/1,NPT
butt weld standard	ISO1127,EN12627,SMS3008
socket weld standard	ANSI B16.11
Face to face	Bolt circle diameter and face to face dimensions of the body is equal to Worcester, Valtac and Mecafrance. This means that the valve body can be installed between existing end caps.
Top Flange	ISO 5211
Tightness Check	API 598
Temperature range	-40°C to +287°C
Operation	Hand lever, pneumatic actuator, electric actuator

B50 High Performance 2PC Flanged Ball Valve



MATERIALS

Body	WCB,CF8,CF8M,CF3M, 2507,904L
Ball	SS304L,SS316L, 2507,904L
Seat	PTFE,RPTFE,P287, Hard seal
Stem	SS304L,SS316L, 2507,904L

TECHNICAL DATA

Connection	Double flange
Nominal diameter	DN15-DN600
operating pressure	10bar,16bar,25bar,50bar
flange standard	EN1092 PN10/PN16/PN25/PN40, ASME B16.5 CLASS150/300
Applicable medium	Water, oil, gas, solution, slurry, powder, particle
top flange	ISO 5211
tightness check	API 598
Temperature range	-40°C to +500°C
Operation	Hand lever, Pneumatic actuator, Electric actuator

B55 Ceramic Flanged Ball Valves



MATERIALS

Body	WCB, CF8
Body lining	Ceramic
Ball	Ceramic
Seat	Ceramic
Stem	SS304

TECHNICAL DATA

Connection	Double flange
Nominal diameter	DN15-DN300
Operating pressure	10bar, 16bar
Flange standard	EN1092 PN10,PN16
Face to face	Show in drawings
Top flange	ISO 5211
Tightness check	ISO5208 Category 3
Temperature range	-29° C to + 200° C (Depending on pressure, medium and material)
Operation	Gear box, Pneumatic Actuator, Electric actuator

B55F Teflon Lined Ball Valve

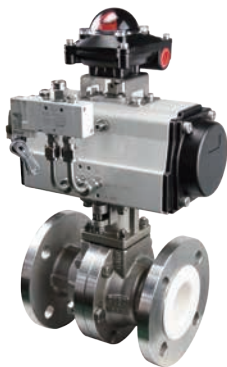

MATERIALS

Body	WCB+PTFE/F46/PFA CF8+PTFE/F46/PFA CF8M+PTFE/F46/PFA
Ball	SS304+PTFE/F46/PFA SS316L+PTFE/F46/PFA
Stem	SS304+PTFE/F46/PFA SS316L+PTFE/F46/PFA

TECHNICAL DATA

Connection	Double flange
Nominal diameter	DN15-DN200
Operating pressure	10bar, 16bar
Flange standard	EN1092 PN10,PN16
Face to face	Show in drawings
Top flange	ISO 5211
Tightness check	ISO5208
Temperature range	-29° C to + 200° C (Depending on pressure, medium and material)
Operation	Gear box, Pneumatic Actuator, Electric actuator

B70 Wafer Flanged Ball Valves



MATERIALS

Body	CF8M CF8 WCB
Ball	SS316L SS304 SS304
Seat	PTFE, RPTFE
Stem	SS316L SS304 SS304

TECHNICAL DATA

Connection	Wafer suitable for flange of EN1092-1
Nominal diameter	1/2"-6"
Pressure rating	PN40
Face to face	Industrial standard
Temperature range	-20°C ~ + 200°C
Operation	Hand lever, Pneumatic actuator, Electric actuator

B72 INF Dome Valve



MATERIALS

Body	CF8 CF8M CF8 with Halar coating CF8 spray with Tungsten coating CF8+ Ceramic
Ball	SS304 SS316L SS304 with Halar coating SS304 with Tungsten coating SS304+Ceramic 100% Ceramic
Stem	SS304 SS316L

TECHNICAL DATA

Connection	Double flange
Nominal diameter	DN50-DN200
Operating pressure	10bar
Flange standard	EN1092 PN10, PN16
Face to face	Show in drawings
Top flange	ISO 5211
Tightness check	API598
Temperature range	-29° C to + 360° C (Depending on pressure, medium and material)
Operation	Pneumatic Actuator,
Gasbag pressure alarm	Optional

B80 Threaded 3 Way Ball Valves



MATERIALS

Body	CF8M
Ball	SS316
Seat	PTFE,RPTFE
Stem	SS316

TECHNICAL DATA

Connection	Threaded BSPP,NPT, BSPT
Size	1/2"-2"
Pressure	PN63
Temperature	-20° C to + 200° C
Operator	Lever,Pneumatic actuator

Z15 Downward Discharge Valves



MATERIALS

Body	CF8,CF8M,CF3M, CF8 with PTFE lined
Ball	SS304L,SS316L, CF8 with PTFE lined
Seat	PTFE,RPTFE,P287,metal seat, inflatable seat

TECHNICAL DATA

Connection	flange
normal diameter	DN80-DN250
Pressure	6bar,10bar
Flange standard	EN1092 PN10/PN16, ASME B16.5 CLASS150
Applicable medium	Water, oil, gas, solution, slurry, powder, particle
tightness check	API 598
Temperature range	-40°C to +500°C
Operation	Hand lever, Pneumatic actuator, Electric actuator

C11 Wafer Lift Check Valves

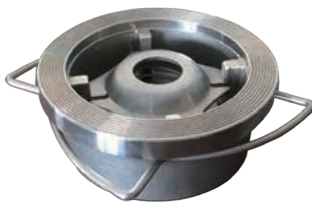

MATERIALS

Body	Steel galvanized,SS316L
Disc	SS304,SS316L,SS304/SS316+EPDM/NBR/VITON
Seat	SS316L

TECHNICAL DATA

Connection	Wafer
Nominal diameter	DN15-DN200
Pressure rating	PN6, PN10, PN16, PN25, PN40; ANSI CLASS150,CLASS300
Face to face	EN558 Series 49 (DIN 3202 K4)
Temperature range	-20° C to +95° C for NBR seat -20° C to +130° C for EPDM seat -20° C to +180° C for FPM seat -29° C to +400° C for metal to metal seat
Coating	Galvanization for steel

C12 Wafer Dual Check Valves



MATERIALS

Body	ASTM A536 65-45-12
Disc	CF8, CF8M
Seat	SS304, SS316

TECHNICAL DATA

Connection	Wafer
Nominal diameter	DN50-DN1200
Pressure rating	PN10, PN16, PN25, ANSI CLASS150
Face to face	EN558 Series 16
Temperature range	-20° C to +85° C for NBR seat -20° C to +130° C for EPDM seat -20° C to +180° C for FPM seat
Coating	Fusion bonded epoxy

C14 Thin Wafer Swing Check Valves



MATERIALS

Body	Steel galvanized, SS316L
Disc	CF8, CF8M
Seat	NBR, EPDM, FPM, Metal to metal

TECHNICAL DATA

Connection	Wafer
Nominal diameter	DN40-DN1000
Standard pressure rating	PN16
Maximum pressure rating	PN40 for DN40-DN100, PN20 for DN125-DN600
Flange accommodation	PN10, PN16, PN25, PN40; ANSI CLASS150
Face to face	Industrial standard
Temperature range	-20° C to +85° C for NBR seat -20° C to +130° C for EPDM seat -20° C to +180° C for FPM seat -29° C to +400° C for metal to metal seat
Coating	Galvanization for steel

C22 Wafer Dual Check Valves



MATERIALS

Body	WCB, CF8, CF8M
Disc	CF8, CF8M
Seat	Metal to metal, NBR, EPDM, FPM
Stem	SS304, SS316

TECHNICAL DATA

Connection	Wafer
Nominal diameter	DN50-DN1200
Pressure rating	PN10, PN16, PN25, ANSI CLASS150
Face to face	EN558 series 16 for rubber seat, API 594 for metal seat
Coating on steel body	Painting system B

C23 Wafer Dual Check Valves



MATERIALS

Body	WCB, CF8, CF8M
Disc	CF8, CF8M
Seat	Cr13, Stellite
Stem	SS304, SS316

TECHNICAL DATA

Connection	Wafer
Nominal diameter	DN50-DN600
Pressure rating	ANSI CLASS300, ANSI CLASS600, ANSI CLASS900, ANSI CLASS1500
Face to face	API 594
Coating on steel body	Painting system B

D11 Knife Gate Valves



MATERIALS

Body	ASTM A536 65-45-12, CF8M
Disc	SS304, SS316
Seat	EPDM, NBR, FPM, PTFE
Stem	AISI 430

TECHNICAL DATA

Connection	Semi-lug
Size	DN50-DN1200
Pressure	16bar for DN50-DN125, 10bar for DN150-DN300, 6bar for DN350-DN600, 4bar for DN700-DN1200
Flange standard	EN1092 PN10/16, ASME B16.5 Class150, JIS B2238 10K, BS10 Table D/E
Face to face	MSS SP-81, TAPPI TIS 405-8
Top flange	ISO 5210
Pressure test	MSS SP-81
Temperature range	NBR seat -15° C to +100° C, EPDM seat -20° C to +130° C, FPM seat -15° C to +180° C, Metal seat -29° C to +400° C
Corrosion protection	Fusion bonded epoxy for DI, Passivation for SS
Operator	Lever, Gear box, Pneumatic actuator, Electric actuator

E01 Basic Electric Actuators



MATERIALS

Body	Aluminum
Weather proof	IP67, IP68

TECHNICAL DATA

Connection	ISO 5211
Torque range	50~2000NM
Switching time	19~155S
Noise Level	Below 75dB within 1M
Space heater	Standard
Motor	Class F insulation, overheating protection

E02 Integrated Electric Actuators



MATERIALS

Body	Aluminum
Weather proof	IP67, IP68

TECHNICAL DATA

Connection	ISO 5211
Torque range	50~2000 NM
Switching time	19~155 S
Noise Level	Below 75dB within 1M
Space heater	Standard
Motor	Class F insulation, overheating protection
Prototype cycle test	100,000 cycles

G20,G21 Angle Pneumatic Valves



MATERIALS

Body	CF8M
Disc	SS316
Seat	PTFE
Stem	SS316
Actuator material	SS304, Aluminum, Plastic

TECHNICAL DATA

Medium for pneumatic	Dry or lubricated air, non-corrosive gas
Pipe medium	Water, neutral gas, oil, water steam, weak acid or weak alkalis
Controlling pressure range	3bar ~ 10bar
Pipe pressure	0.3bar ~ 16bar
Size	DN15-DN65
Air connection	G1/8", G1/4"
Environment temperature	-10 ~ 60°C
Medium temperature	-10 ~ 180°C
Pneumatic acting	G20 double acting, G21 single acting

G33 Forged Globe Valves



MATERIALS

Body	A105, F304, F316
Disc	A105, F304, F316
Seat	Cr13 overlay, Stellite overlay
Stem	SS410, SS304, S316

TECHNICAL DATA

Connection	Butt welding/Socket weld/Screwed ends
Nominal diameter	1/4"-2"
Operating pressure	ANSI Class 800/1500/2500
Tightness check	API 598
Temperature range	-29° C to +400° C (Depending on pressure, medium and material)
Operation	Manual, Pneumatic actuator, Electric actuator

G51 Flanged Globe Valves



MATERIALS

Body	WCB, CF8, CF8M
Disc	WCB, CF8, CF8M
Seat	Same as body, Cr13 overlay, Stellite overlay
Stem	SS410, SS304, S316

TECHNICAL DATA

Connection	Flange
Nominal diameter	2"-24"
Operating pressure	PN10, PN16, PN40; ANSI Class 150/300/600/900
Face to face	Show in drawings
Tightness check	API 598
Temperature range	-29° C to +400° C (Depending on pressure, medium and material)
Operation	Manual, Pneumatic actuator, Electric actuator

H33 Forged Gate Valves



MATERIALS

Body	A105, F304, F316
Disc	A105, F304, F316
Seat	SS304, SS316, Cr13 overlay, Stellite overlay
Stem	SS410, SS304, S316

TECHNICAL DATA

Connection	Butt welding/Socket weld/Screwed ends
Nominal diameter	1/4"-2"
Operating pressure	ANSI Class 800/1500/2500
Tightness check	API 598
Temperature range	-29° C to +400° C (Depending on pressure, medium and material)
Operation	Manual, Pneumatic actuator, Electric actuator

H51 Flanged Gate Valves



MATERIALS

Body	ASTM A536 65-45-12, WCB, CF8, CF8M
Disc	ASTM A536 65-45-12 with EPDM lined, WCB, CF8, CF8M
Seat	Same as body, SS304, SS316, Cr13 overlay, Stellite overlay
Stem	SS410, SS304, S316

TECHNICAL DATA

Connection	Flange
Nominal diameter	2"-60"
Operating pressure	PN10, PN16, PN40; ANSI Class 150/300/600/900
Face to face	Show in drawings
Tightness check	API 598
Temperature range	-29° C to +400° C (Depending on pressure, medium and material)
Operation	Manual, Pneumatic actuator, Electric actuator

MCCS Multipoint Centralized Control System

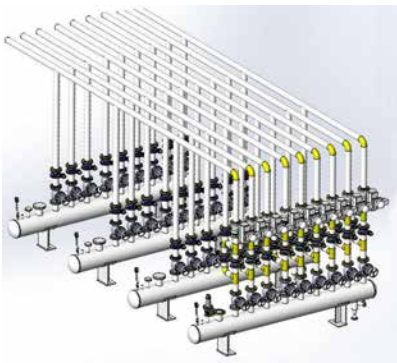

MATERIALS

Human-computer interaction	LCD touch screen, mobile phone, computer
Control	Pneumatic valves, electric valves
Application	Remote centralized control

TECHNICAL DATA

Points	Hundreds of valves can be controlled independently or jointly
Flow control	Programmable
Switch linked	Programmable
Man/auto switch	Yes
System reset	Yes
Parameter setting button	Yes
Working pressure alarm	Yes
Emergency stop	Yes

J12 Threaded Double Sphere Rubber Expansion Joints



MATERIALS

Rubber	EPDM, CR, NBR, FPM
Fabric	Nylon
Threaded connection	Malleable iron

TECHNICAL DATA

Connection	Thread BSPP,NPT
Nominal diameter	1/2"-3"
Pressure rating	PN10
Vacuity	400mmHg
Temperature range	-20° C to +200° C (depending on rubber material)

J13 Flanged Single Sphere Rubber Expansion Joints



MATERIALS

Rubber	EPDM, CR, NBR, FPM
Fabric	Nylon
Reinforcement ring	Steel galvanized
Flange	Steel galvanized

TECHNICAL DATA

Connection	Flanged PN16, PN10, PN6
Nominal diameter	DN25-DN1600
Pressure rating	PN16 for DN25-DN300, PN10 for DN350-DN600, PN6 for DN700-DN1600
Vacuity	750mmHg for DN25-DN300, 500mmHg for DN350-DN600, 300mmHg for DN700-DN1600
Temperature range	-20° C to +200° C (depending on rubber material)

J14 Flanged Double Sphere Rubber Expansion Joints



MATERIALS

Rubber	EPDM, CR, NBR, FPM
Fabric	Nylon
Reinforcement ring	Steel galvanized
Flange	Steel galvanized

TECHNICAL DATA

Connection	Flanged PN16, PN10, PN6
Nominal diameter	DN32-DN500
Pressure rating	PN16 for DN32-DN200, PN10 for DN250-DN500
Vacuity	500mmHg for DN32-DN200, 400mmHg for DN250-DN500
Temperature range	-20° C to +200° C (depending on rubber material)

P01 Intelligent EP Valve Positioner



TECHNICAL DATA

Input signal	4 ~ 20mA(2 wire), minimum 3.6mA	Linearity	0.5%F.S.
Supply pressure	0.14Mpa ~ 0.7Mpa (1.4Bar ~ 7Bar)	Hysteresis	±1%F.S.
Stroke	Linear: 10 ~ 100mm, Rotary: 30°~ 120°	Repeatability	0.2%F.S.
Air connection	1/4BSPP, 1/4NPT	Air consumption	< 36L/H
Conduit	M20-1.5, 1/2BSPP, 1/2NPT	Vibration effect	2G
Weather proof	IP65	Dimension	170x96x96mm
Explosion proof	Exia II CT4-6, or Exd II CT6	Material	Aluminum alloy with polyester powder
Ambient temperature	-20°C~ 70°C	Weight	2.0Kg

P02 Electric-Pneumatic Valve Positioner



TECHNICAL DATA

Input signal	4 ~ 20mA DC	Explosion proof	Exia II CT4-6, or Exd II CT6
Impedance	250±15 Ohm	Ambient temperature	-20°C~ 70°C (Operating), -20°C~ 60°C (Explosion)
Supply pressure	0.14Mpa ~ 0.7Mpa (1.4Bar ~ 7Bar)	Linearity	±1%F.S. for single acting, ±2%F.S. for double acting
Stroke	Linear: 10 ~ 150mm, Rotary: 0°~ 90°	Hysteresis	±1%F.S.
Air connection	PT(NPT)1/4"	Sensitivity	±0.4%F.S. for single acting, ±0.8%F.S. for double acting
Gauge connection	PT(NPT)1/8"	Repeatability	±0.5%F.S.
Conduit	PF1/2"(G1/2")	Material	Aluminum alloy with polyester powder
Weather proof	IP65	Weight	2.7Kg

P04 Valve Indicator



TECHNICAL DATA

Encase material	ABS	Sensor position	-45°/+45° ±10°
Contact form	Normally Open(NO)	Operating Temp.	-40°C~ +85°C
Output type	2 wire	Proximity distance	1 ~ 6mm
Switching capacity	1W ~ 10W	Mounting	Standard: 30x80 H:20,30 Requiring: 30x130 H:20,30
Switching voltage	5VDC/240VAC	Fasteners	Stainless steel
Switching current	0 ~ 300mA	Wiring	FL: Flying lead(70mm) P4: M12-4p wiring connector
Switching frequency	0 ~ 4.8KHz		

P22 Solenoid Valve



TECHNICAL DATA

Spool valve/ Body	Extruded aluminum	Fasteners	Stainless steel
Coating	Anodized coated, or Nickel coated in chemical	Environment	Indoor and outdoor
Seal	Buna N	Medium Temperature	-25°C~ 80°C
Materials in contact with fluid	Aluminum, Glass-filled PA, POM, Buna N	Working Pressure	2 ~ 8 bar
Function	5/2 and 3/2 NC, Monostable CV=1.1(19.63mm ²), 1082 l/ min	Working Medium	Less than 40um filtered and dried air
Air Ports	Air ports 1/4" BSPP or NPT	Bistable	Available on requiring
Assembly and connection	24x32 Namur, Manual override on body	Working life	More than 1000,000 cycle (On the normal working condition) P4: M12-4p wiring connector

P30 Air Pressure Regulator



TECHNICAL DATA

Operating medium	Air
Adjustable pressure range	0.15 ~ 0.9MPa
Max. adjustable pressure	1.0MPa
Pressure resistance ensurance	1.5MPa
Operating Temp. range	-20 ~ 70°C
Connection	G thread (PT,NPT are available on request)

P31 Air Pressure Filter



TECHNICAL DATA

Operating medium	Air
Joint pipe bore	G thread (PT,NPT are available on request)
Filter element roughness	40um & 5um
Adjustable pressure range	0.15 ~ 0.9MPa
Max. adjustable pressure	1.0MPa
Pressure resistance ensurance	1.5MPa
Operating temperature range	5 ~ 60°C
Suggested lubricant	ISO VG 32 or same grade oil
Max adjustable pressure for low pressure type	0.4MPa

P40,P41 Pneumatic Actuators



TECHNICAL DATA

Operating medium	Dry or lubricated air, non-corrosive gas
Air supply pressure	2.5bar ~ 8bar
Travel adjustment	Adjustable +5° /-5° by 0° and 90° position
Lubrication	Pre-lubricated for life of actuator on assembly under normal operating conditions
Operating temperature	-20 ~ 80°C ,NBR O-ring -35 ~ 80°C ,Silicon O-ring -15 ~ 150°C ,FPM O-ring
Connection	ISO5211
Max adjustable pressure for low pressure type	0.4MPa

P60 Limit Switch



TECHNICAL DATA

Weather proof	IP67	
Explosion proof	Exd II CT6	
Temperature range	-25°C~ +85°C	
Cable entry	2x3/4NPT	PT3/4, PF3/4
Terminal strips	8	9 ~ 24
Position range	0 ~ 90°	0 ~ 180°
Position indicator	Open-Yellow; Close-Red	
Switches	Mechanical, proximity, magnet	
Potentiometer	1KΩ(0 ~ 5KΩ, 0 ~ 10KΩ)	
Current feedback	4 ~ 20mA	

P61 Limit Switch



TECHNICAL DATA

Weather proof	IP67	
Temperature range	-25°C ~ +85°C	
Cable entry	2x1/2NPT	PT1/2, PF1/2, M20 PG13.5
Terminal strips	8	9 ~ 24
Position range	0 ~ 90°	0 ~ 180°
Position indicator	Open-Yellow; Close-Red	
Switches	Mechanical, proximity	

P70 Solenoid Valve



TECHNICAL DATA

Construction	5/2, 3/2 way	Temperature	-25°C to +80°C
Air consumption	1100 L/min at 5bar	Connection	NAMUR, 1/4" inlet/outlet. Optional: NAMUR, 1/2" inlet/ outlet
Flow rate	Kv=0.95 m³/h	Medium	Air or inert gas
Pressure single coil	2bar to 8bar	Air quality	DIN/ISO 8573-1 Class3
Coils	24VDC, 24VAC, 230VAC. Optional 110 V	Wire connection	DIN 46244
Voltage indication	LED(Light emitting diode)	Protection class	IP65 NEMA 4, 4X coil
Current consumption	24VDC-4W, 24VAC-4VA, 230VAD-4VA	Surface	Hard anodized-20µ

S12 Flanged Ductile Iron Y Strainers



MATERIALS

Body	ASTM A536 65-45-12
Screen	SS304

TECHNICAL DATA

Connection	Flange
Nominal diameter	DN50-DN600
Pressure rating	PN16
Face to face	EN558-1 series 1
Temperature range	-20° C to +230° C
Coating	Fusion bonded epoxy

S21 Threaded Stainless Steel Y Strainers



MATERIALS

Body	CF8M
Screen	SS316

TECHNICAL DATA

Connection	Threaded BSSPP, NPT
Nominal diameter	1/4"-3"
Pressure rating	PN60
Temperature range	-20° C to +230° C

S22 Flanged Cast Steel Y Strainers



MATERIALS

Body	WCB, CF8, CF8M
Screen	SS304, SS316

TECHNICAL DATA

Connection	Flange
Nominal diameter	DN50-DN600
Pressure rating	PN16
Face to face	EN558-1 series 1
Temperature range	-20° C to +230° C
Coating	Painting system B

Valve Selection Table

classification	shut-off valve						check valve
	blocking type	sliding type	rotary type			clamp type	
	globe valve	gate valve	plug valve	ball valve	butterfly valve	diaphragm valve	
construction feature	simple structure and easy to manufacture and maintain.	short face to face dimension, good manufacture process, wide range of application and complex structure	simple structure, relatively small volume and light weight, easy to maintain and be made three way or four way valve	simple structure, relatively small volume and light weight, easy to maintain and be made three way or four way valve	simple structure, small volume and light weight, larger size and more advantaged, not suitable for high pressure	smoothing cavity and east to catch hygiene requirement	open automaically at downflow and close automatically at upflow
tightness	good tightness, small friction between seals and long lifetime	The seal surface is slightly washed and erodde by medium. It is difficult to maintain when the seal surface is grazed.	good tightness	good tightness	good tightness under low and medium pressure	good tightness under low pressure	with self-sealing performance
medium	The flow direction of medium should be consistent with the direction of arrow on body. This is not suitable for medium with large particle viscosity and easy coking.	The flow direction of medium is out of restriction. No flow obstruction and small resistance.	The install direction is out of restriction. It is suitable for low temperature and high pressure situation and medium with large viscosity.	The install direction is out of restriction and suitable for medium under high pressure.	With opitimized desision, it can delivery slurry and accumulate less medium at pipe.	According to the corrosion resistance of diaphragm and lining materials, it is suitable for various corrosive media.	Different structures and materials are suitable for different media.
regulation performance	good regulation performance	only to be full-open and full-closed, no regulation performance and throttle fuction	poor regulation performance	poor regulation performance	good regulation performance	good regulation performance	Part of check valves have throttle fuction
fluid resistance	great fluid resistance	low fluid resistance	low fluid resistance	low fluid resistance	low fluid resistance	low fluid resistance	low fluid resistance for swing type and great fluid resistance for lift type
operation	The working stroke is small. It takes a lot of time and force to open and close.	It is more labor-saving to open, but it needs a certain space to open and close, and it takes a long time.	The valve can be operated frequently and convenient to open and close.	The valve can be operated frequently and convenient to open and close.	The valve can be operated frequently and convenient to open and close.	It's easy to operate but the force is larger when close the valve.	automatic open and close

valve Selection Table

Condition	Rating						Medium				Hand lever(wheel), Pneumatic, Electric, Hydraulic		Self function
	Vacuum to PN16	PN20	PN25	PN50	PN100 and higher	Temperature (°C)	W.O.G.	Granule	Slurry	Corrosive	On-off	Regulating	Non-return
A23	●	●	●	●	●	-40~180	●	●	●	●	●	●	●
A25	●	●	●	●	●	-40~200	●	●	●	●	●	●	●
A31	●	●	●	●	●	-40~200	●	●	●	●	●	●	●
A73	●	●	●	●	●	-40~400	●	●	●	●	●	●	●
B10	●	●	●	●	●	-40~200	●	●	●	●	●	●	●
B20	●	●	●	●	●	-40~200	●	●	●	●	●	●	●
B25	●	●	●	●	●	-40~200	●	●	●	●	●	●	●
B33	●	●	●	●	●	-40~200	●	●	●	●	●	● V-port	●
B35	●	●	●	●	●	-40~200	●	●	●	●	●	● V-port	●
B50	●	●	●	●	●	-40~200	●	●	●	●	●	● V-port	●
B53	●	●	●	●	●	-40~200	●	●	●	●	●	● V-port	●
B61	●	●	●	●	●	-40~400	●	●	●	●	●	● V-port	●
B63	●	●	●	●	●	-40~400	●	●	●	●	●	● V-port	●
C12	●	●	●	●	●	-40~200	●	●	●	●			●
C14	●	●	●	●	●	-40~400	●	●	●	●			●
C15	●	●	●	●	●	-40~400	●	●	●	●			●
C22	●	●	●	●	●	-40~200	●	●	●	●			●
C23	●	●	●	●	●	-40~400	●	●	●	●			●
D11	●	●	●	●	●	-40~600	●	●	●	●	●	●	●

Legend

Excellent	●
Good	●
Not Recommend	●

Valve material chemistry chart

Materials	316 SS	416 SS	EPDM	Aluminium bronze	Nickel plated ductile iron	Butyl rubber	fluororubber	Polytetra fluoroethylene
acetate-pure	●	●	●	●	●	●	●	●
acetone	●	●	●	●	●	●	●	●
Air (dry)	●	●		●	●	●		●
Alcohol - butyl	●	●	●	●	●	●	●	●
alcohol-ethyl	●		●	●	●	●	●	●
alcohol-methyl	●		●	●	●	●	●	●
amines	●	●	●		●	●		●
ASTM Oil #1	●	●	●	●	●	●		●
ASTM Oil #3	●	●	●	●	●	●		●
pitch	●	●	●	●	●	●		●
Beer (beverage)	●	●	●	●	●	●		●
Benzene (benzene)70° F	●	●	●	●	●	●	●	●
Bleach powder - wet	●	●	●	●	●	●	●	●
Brine chlorination			●					●
Butane -- butene	●	●	●	●	●	●	●	●
butanol	●		●		●	●	●	●
Calcium carbonate 60° F			●		●	●	●	●
Calcium hydroxide 50% 175° F	●	●	●	●	●	●	●	●
Carbon dioxide	●	●	●	●	●	●	●	●
Castor oil	●	●	●	●	●	●	●	●
Chlorine gas - Dry 70°	●	●	●	●	●	●	●	●
Liquid chlorine	●	●	●			●	●	●
chlorobenzene 90% 70° F	●	●	●	●	●	●	●	●
Citric acid 5% 150° F	●	●	●	●	●	●	●	●
Coal slurry			●			●		●
Coconut Oil (Food)	●	●	●	●	●	●	●	●
Coffee (food)	●	●	●	●	●	●	●	●
Cottonseed oil	●	●	●	●	●	●	●	●
abluent	●		●			●		●
Diesel oil	●	●	●	●	●	●	●	●
Epsom salt			●			●		●
Ethylene glycol			●			●		●
Ethylene glycol (antifreeze)	●	●	●	●	●	●	●	●
Ethylene oxide	●	●	●		●	●	●	●
formaldehyde 70° F	●	●	●	●	●	●	●	●
Fuel oil	●	●	●	●	●	●		●
Gelatin (food)	●	●	●	●	●	●	●	●

Valve material chemistry chart

Materials	416 SS	EPDM	Aluminium bronze	Nickel plated ductile iron	Butyl rubber	fluororubber	Polytetrafluoroethylene	Polytetrafluoroethylene
Ethylene glycol 70° F						●	●	●
Sulfate green liquor	●	●	●	●	●	●		●
35% hydrochloric acid at 60° F	●	●	●	●	●	●	●	●
90% hydrogen peroxide	●	●	●	●	●	●	●	●
isobutanol			●			●	●	●
Isopropyl alcohol	●	●	●	●	●	●	●	●
Jet fuel JP-6			●			●	●	●
Lubricating oil	●	●		●	●	●	●	●
butanone	●	●	●	●	●	●	●	●
Milk (food)	●		●	●	●	●		●
monochlorobenzene			●			●	●	●
Natural gas	●	●	●	●	●	●	●	●
Olive oil			●			●		●
Breath	●	●	●	●	●	●		●
perchloroethylene	●	●	●		●	●	●	●
10% phosphoric acid 70° F	●	●	●	●	●	●	●	●
25% phosphoric acid 70° F	●	●	●	●	●	●	●	●
Potassium carbonate	●		●	●	●	●	●	●
Potassium chloride	●		●	●	●	●	●	●
propane	●	●	●	●	●	●	●	●
Propyl alcohol	●	●	●			●	●	●
propanediol 70° F			●			●		●
seawater 70° F	●	●	●	●	●	●	●	●
sewage	●	●	●	●	●	●	●	●
Silicone oil	●	●	●	●	●	●	●	●
Silicone oil	●	●	●	●	●	●	●	●
Liquid soap (stearate) 70° F	●	●	●	●	●	●	●	●
Sodium bicarbonate	●	●	●	●	●	●	●	●
Sodium bisulfate	●	●	●		●	●	●	●
Sodium chlorate	●		●		●		●	●
50% Sodium hydroxide	●	●	●	●	●	●	●	●
5% Sodium hypochlorite 60° F	●		●	●	●	●	●	●
225° F steam	●	●	●	●	●	●	●	
300° F steam	●	●		●	●	●	●	
60° F Sulfur dioxide	●	●		●	●	●	●	●
Sulfur trioxide	●	●	●		●	●		●
0-7% vitriol 70° F	●	●	●	●	●	●	●	●

Valve material chemistry chart

	316 SS	416 SS	EPDM	Aluminium bronze	Nickel plated ductile iron	Butyl rubber	fluororubber	Polytetrafluoroethylene	Polytetrafluoroethylene
7-40% vitriol 70° F	●	●	●	●	●	●	●	●	●
40-75% vitriol 70° F	●	●	●	●	●	●	●	●	●
75-95% vitriol	●	●	●	●	●	●	●	●	●
95-100% vitriol	●	●	●	●	●	●	●	●	●
80% Sulfurous acid 100° F	●	●	●	●	●	●	●	●	●
Tall oil	●	●	●	●	●	●	●	●	●
Tannic acid 150° F	●	●	●	●	●	●	●	●	●
Tar oil	●	●	●	●	●	●	●	●	●
Tartaric acid 150° F	●	●	●	●	●	●	●	●	●
Lead tetraethyl				●			●	●	●
tetrahydrofuran	●			●			●		●
Toluene and toluene	●	●	●	●	●	●	●	●	●
Transformer oil	●	●	●	●			●	●	●
Tributyl phosphate	●	●	●	●		●	●	●	●
Trichloroacetic acid			●	●	●			●	●
trichloroethylene	●	●	●	●	●	●	●	●	●
Triethanolamine			●	●		●		●	●
triethylamine							●	●	●
Trisodium phosphate			●	●		●	●	●	●
Tung oil	●	●	●	●		●	●	●	●
turpentine	●	●	●	●	●	●	●	●	●
urea	●			●		●		●	●
varnish	●	●	●		●	●		●	●
70° F vinegar	●			●		●	●	●	●
Acid mine water	●			●		●	●	●	●
Deionized water	●	●	●	●	●	●	●	●	●
180° F Fresh water	●	●	●	●	●	●	●	●	●
225° F Fresh water	●	●	●	●	●	●	●	●	●
180° F Salt water	●	●	●	●	●	●	●	●	●
80° F sewage	●	●	●	●	●	●	●	●	●
Whisky and wine	●	●	●	●	●	●	●	●	●
White spirit	●			●		●	●	●	●
xylene	●	●	●	●	●	●	●	●	●
Zinc acetate				●			●	●	●
5% Zinc chloride 160° F	●	●	●	●	●	●	●	●	●
25% Zinc sulfate 180° F	●	●	●	●	●	●	●	●	●

Due to improvement, all the recorded contents in the catalogue may change without notice. Please kindly understand that the products shown may vary slightly compared with actuals in terms of color, etc. due to printing and other factors.

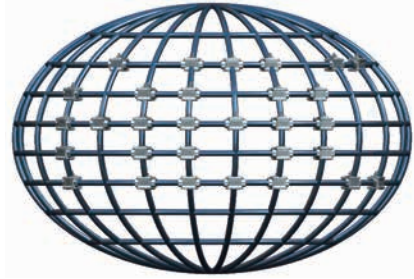

Manufacture:
ABC VALVE WUXI CO., LTD.

Add: U Valley Industrial Park, 58 Jinghong Road, Xibei Town, Xishan District, Wuxi, Jiangsu, China
Zip Code: 214195
Tel: +86-510-88786886
Email: info@abcvalve.com
Web: www.abcvalve.com

Manufacture in Singapore:
ABC VALVE PTE. LTD.

Add: 10 ANSON ROAD
#13-15
INTERNATIONAL PLAZA
SINGAPORE (079903)
Email: sg@abcvalve.com

