

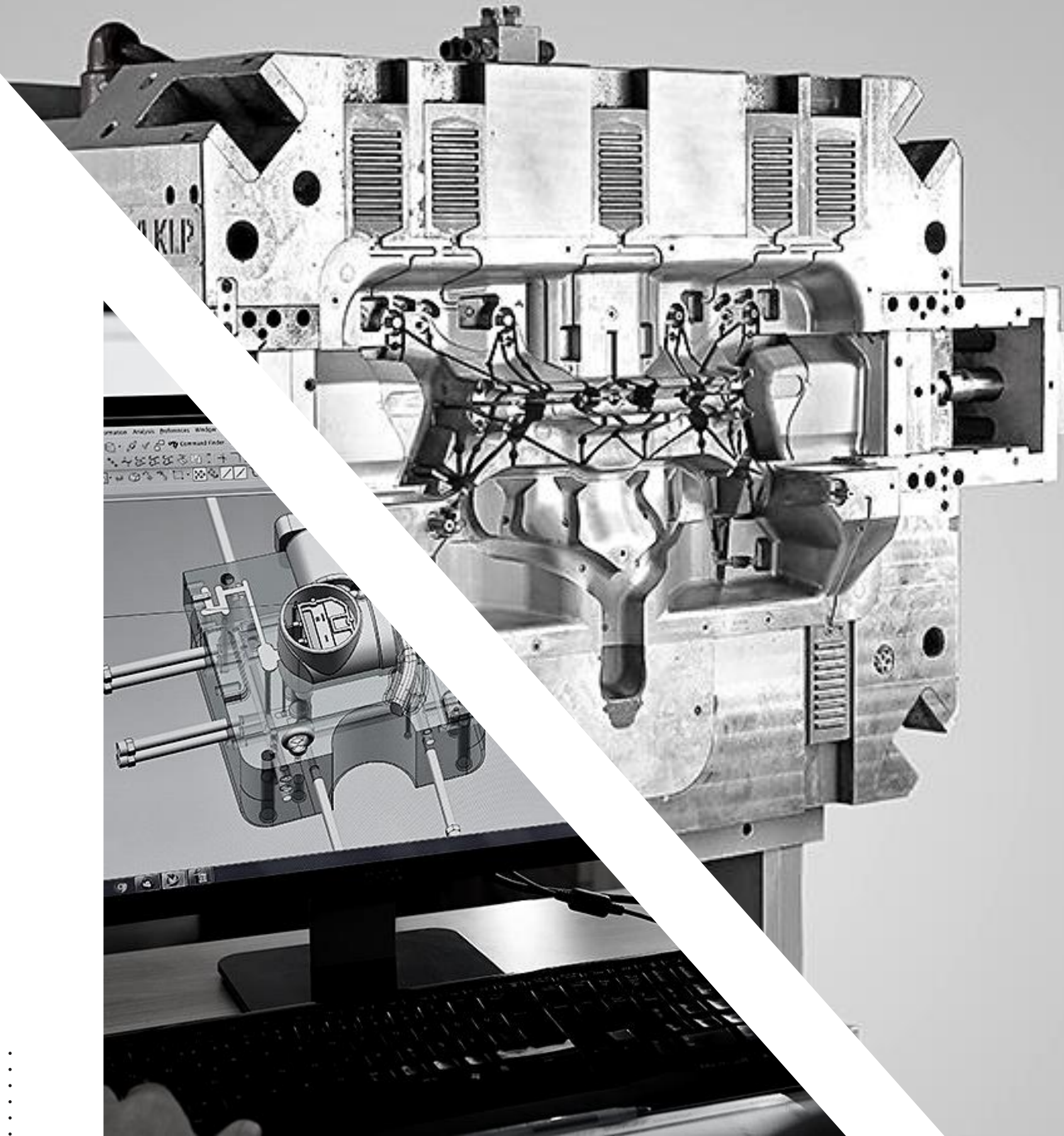

**MODERN KALIP**

*Forming your ideas*

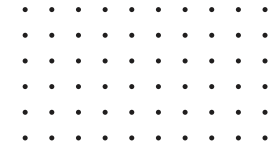

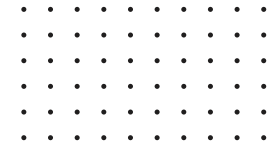
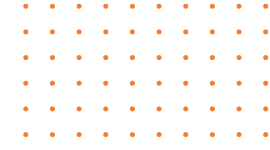

# WELCOME TO OUR COMPANY

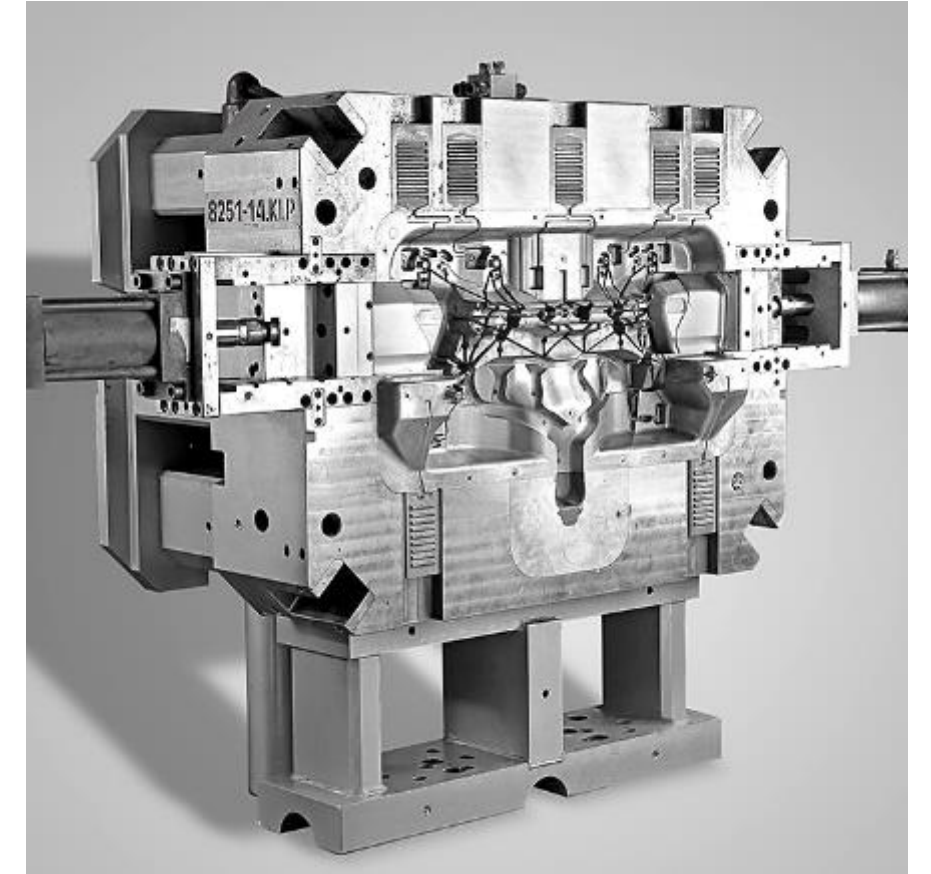

One of the biggest HPDC mold design and manufacture company in TÜRKİYE

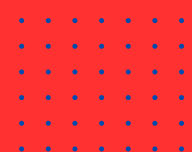

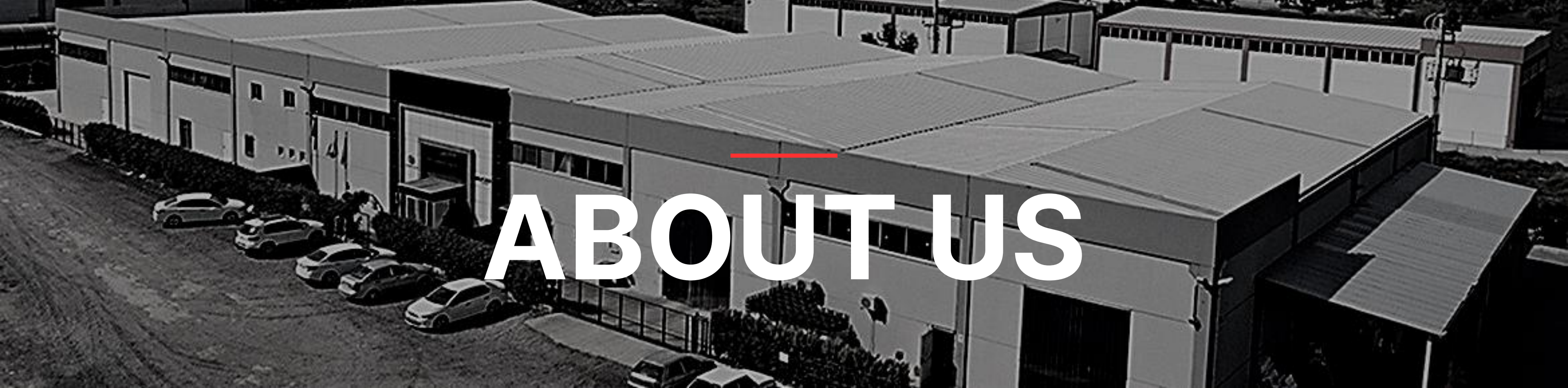

# ABOUT US

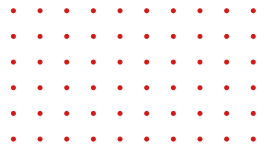

MODERN KALIP was founded in 1998 in Manisa Kenan Evren Industrial Zone. The company had 1 CNC band in a 100 m2 area at the time. In their first years, company generally produced metal injection moulds. By growing at a trot, the company extended its service and business capacity by opening a new facility in Manisa Medium-Sized Industry Zone in 2007. MODERN KALIP which extended its quality and service by adding new CNC bands with high- quality working capacity,increased its client portfolio by entering also the foreign markets.

MODERN KALIP which had a new facility in 2014 with 3500 m2 indoor and totally 6000 m2 central molding room and other subsidiary organs,continues to serve with its experienced and professional staff and cutting-edge technological devices in the fields of high pressured die casting, low pressured die casting and plastic injection molds.

MODERN KALIP which has the motto of "Solution partner", always takes providing clients with the best,themost economical and the highest quality service on as a duty.

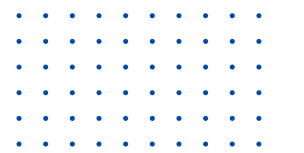

MODERN KALIP

---

# OUR HISTORY

**1998**

Established in Manisa Kenan Evren Industrial Zone

**2007**

Extended its production capacity by moving new facility in Manisa Medium-Sized Industry Zone

**2014**

Moved new facility with its subsidiary company and extend its manufacturing capacity.

**2023**

Extend and develop its machinery plan and has total 8 CNC machine.



# WHY US?



*We bear the responsibility of being a fair, honest, trustworthy and innovative establishment. We are in the hot pursuit of the technology and innovations related to our sector such as mould manufacturing, plastic injection mould design, aluminum mould design and production. We provide with human and logistics resources and work with our clients with the sense of solution partnership...*

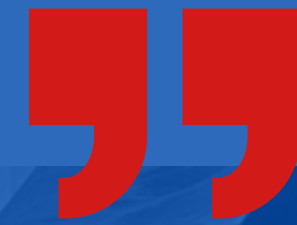

[www.modernkalip.com](http://www.modernkalip.com)

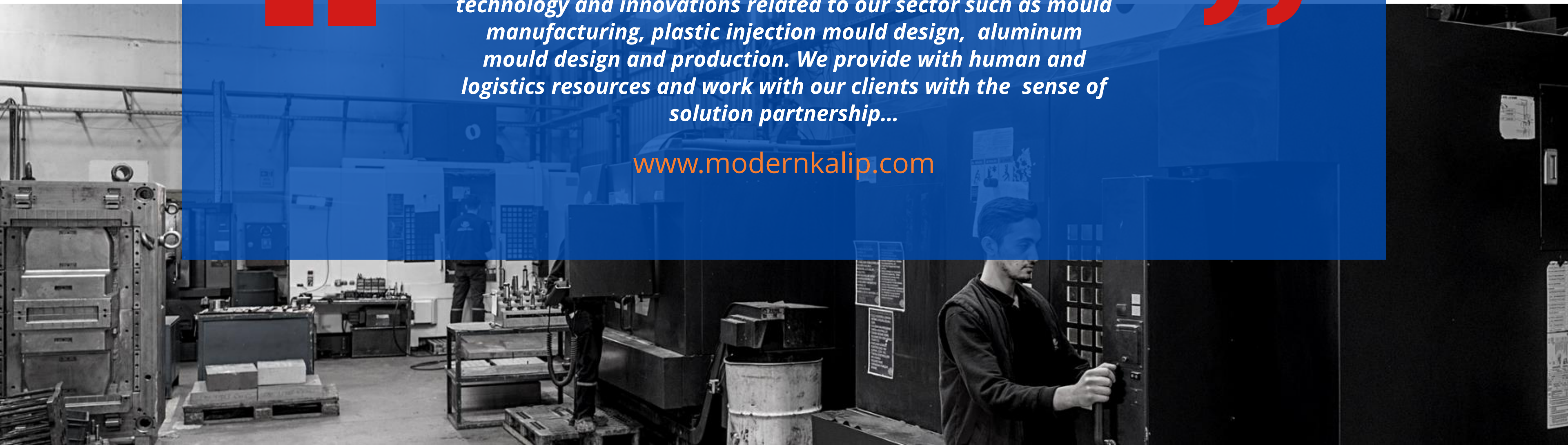

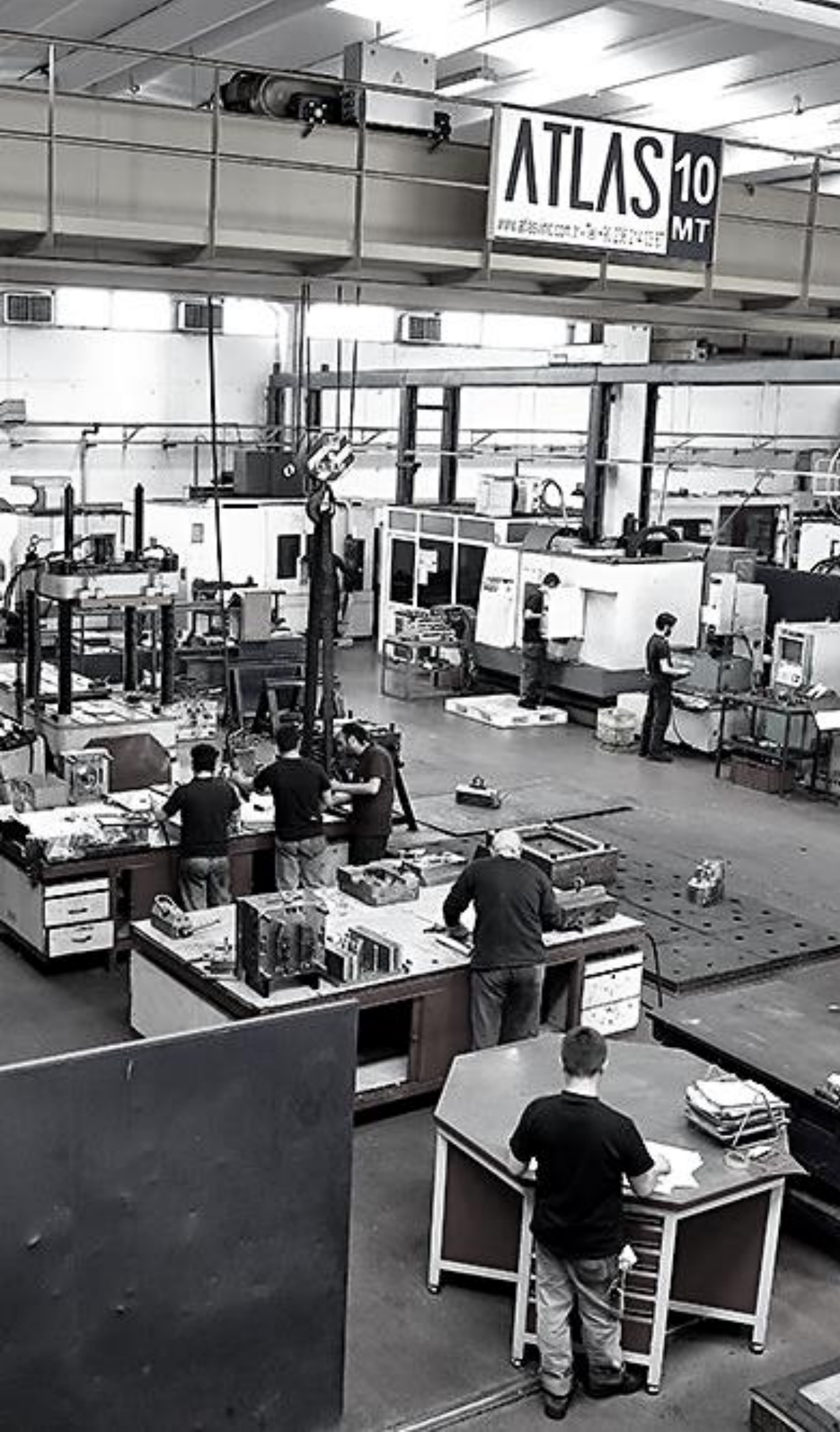

---

# OUR MISSION



## 01.

As MODERN KALIP we approach our clients' demands as a service with which we can provide with the most suitable and the fastest solution; for this reason, it is not just a mould manufacturing for us

## 02.

We believe that we are not just a mould producer but we are a "Solution Partner" for our clients and we do our best to achieve that.

# OUR VISION

01.

Our objective is to become the leading company in the sector and in the area with cutting-edge technological devices as well as with the innovative, experienced and expert staff of MODERN KALIP, to carry out investments which are beneficial for the economy of the country and to provide foreign market with the high quality and economical solutions.

02.

MODERN KALIP aims to design and produce the most suitable and high quality moulds in the light of client demands.

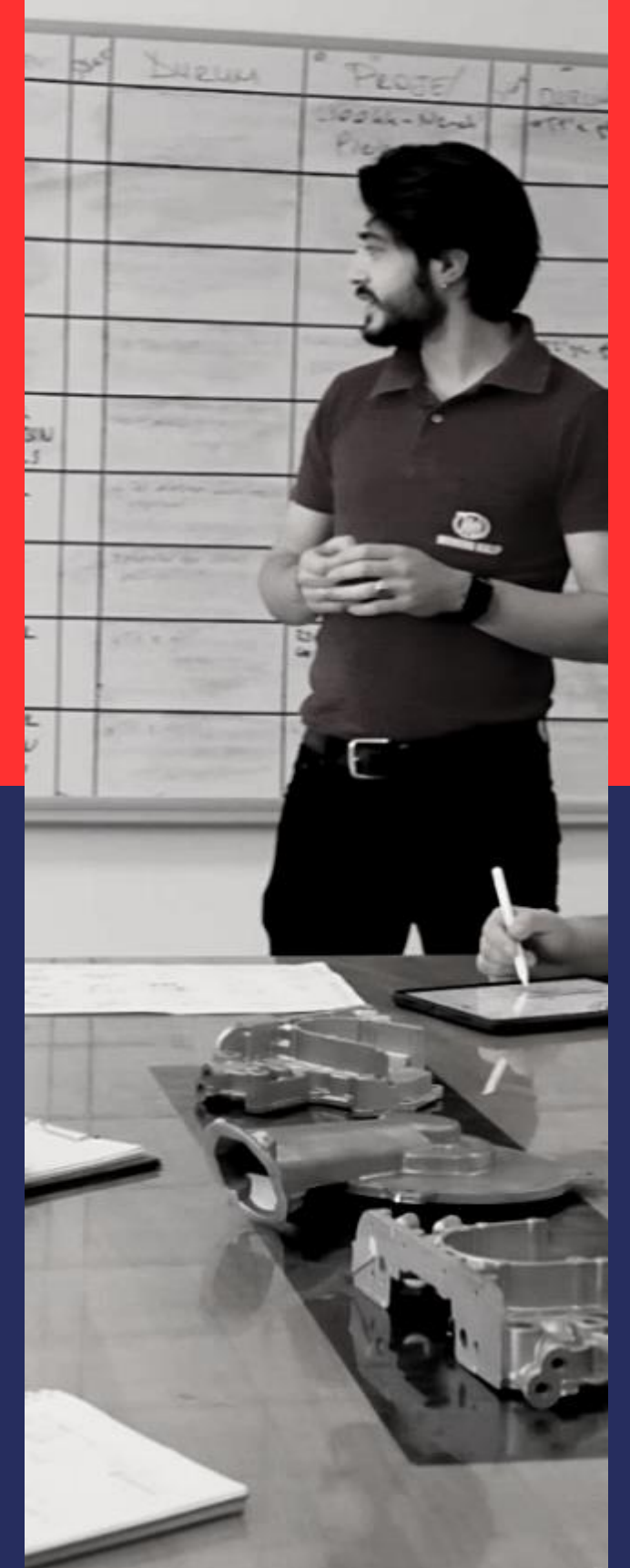
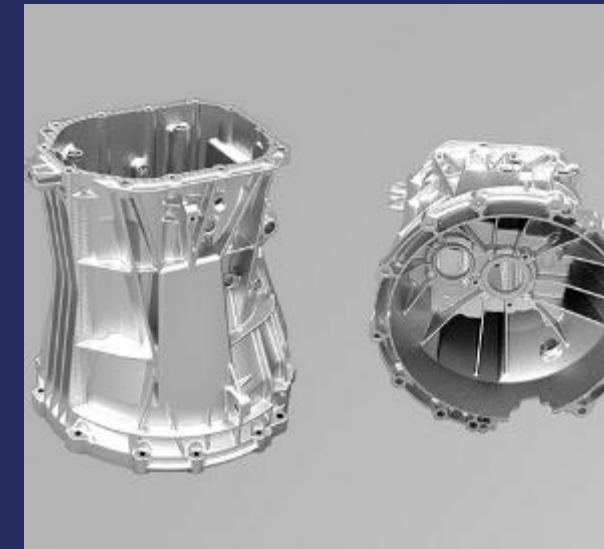

---

# SPECIALITIES

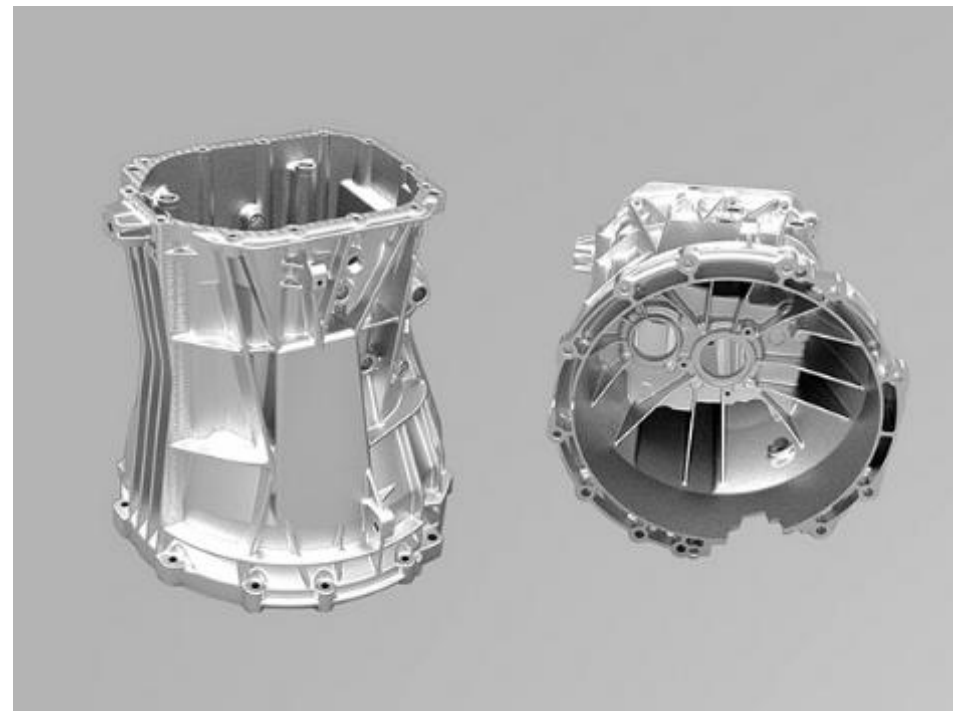
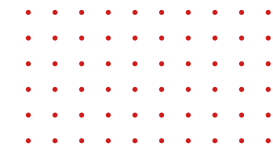
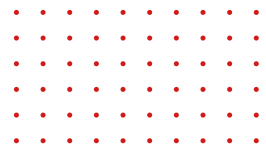

## HIGH PRESSURED & LOW PRESSURED DIE CASTING

- Product / Part Analysis for Moulding
- Runner Design
- Mold Design
- Mold Manufacturing
- Reverse Engineering
- Background know-how for and experience for high tonnaged die casting tools

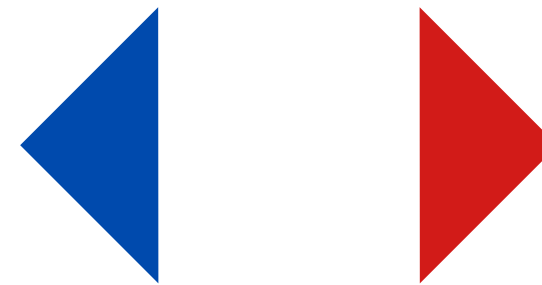

## PLASTIC INJECTION

- Product Design
- Customer oriented production design
- Market Search
- Part analysis
- Hot Runner Analysis (flow simulation)
- Product Technical design
- Reverse engineering
- Mold Design
- Mold Manufacturing



---

# RESEARCH & DEVELOPMENT

With its experienced R&D team, MODERN KALIP approaches its customers' demands with the point of view of solution and business partner. Before analyzing the products in terms of molding, MODERN KALIP provides with the most proper and most qualified solution to the customers by making analysis for the market, user problems, reclamation and reverse engineering.

With the help of cutting edge software such as Solidworks and Unigraphics, the designs are made. At the same time, the company has a point of view which is open to improvement and innovative as it internalizes the knowledge and experiences obtained from each project. In order to take these experiences, knowledge and skills one step further, MODERN KALIP carries out projects with universities. By using university-industry cooperation, it contributes to the economy of the country and to the innovation.

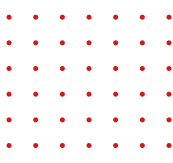
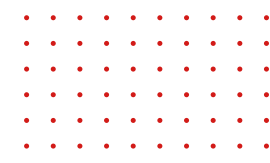
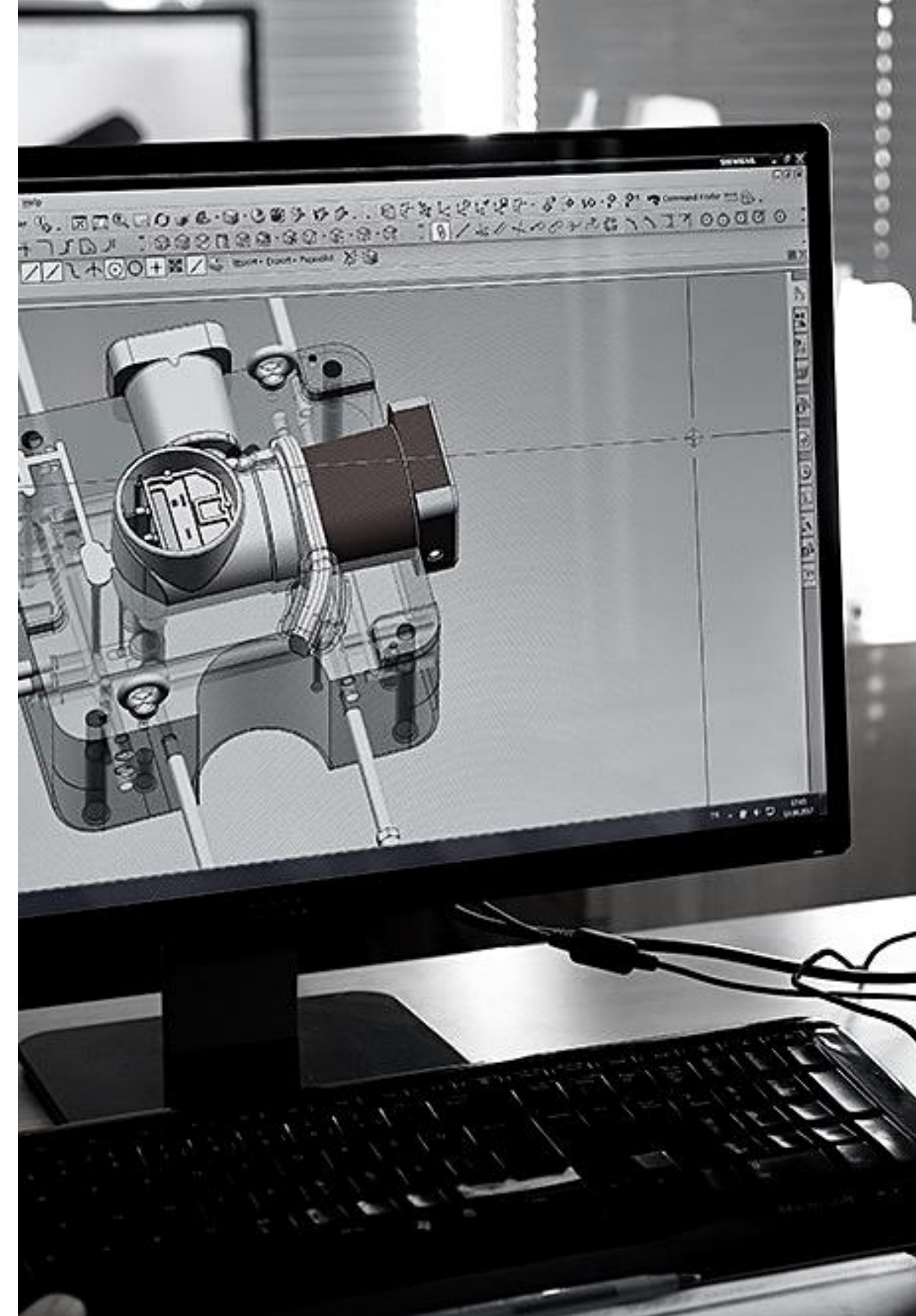

---

# ANALYSIS

MODERN KALIP provides its customers with constructive, of high quality and fast solutions by carrying out the necessary analysis before manufacturing the products with the help of programs such as CAD/CAE which are used within R&D and with the help of its experienced staff. The analysis such as Statics, Dynamics, Deformation, Stress, Drop-Crush tests for plastics are done thanks to ANSYS program. Thanks to these analyses, delivery of the most proper and ideal product is prepared by minimizing the foreseen problems before manufacturing the product. MODERN KALIP is going forward for being a R&D company with the perfection of ANSYS program which is not usual for a standard mold producing company. The most proper mold and injection parameters can be decided by making filling analyses of the plastic parts. The company can design proper gate and air ducts for the metal injection parts thanks to its R&D and know-how experiences.

Solidworks Plastics is used for flow simulations of the plastic parts.

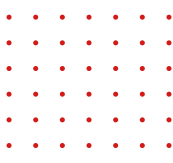
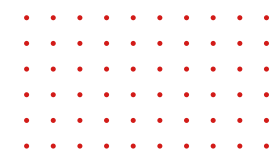
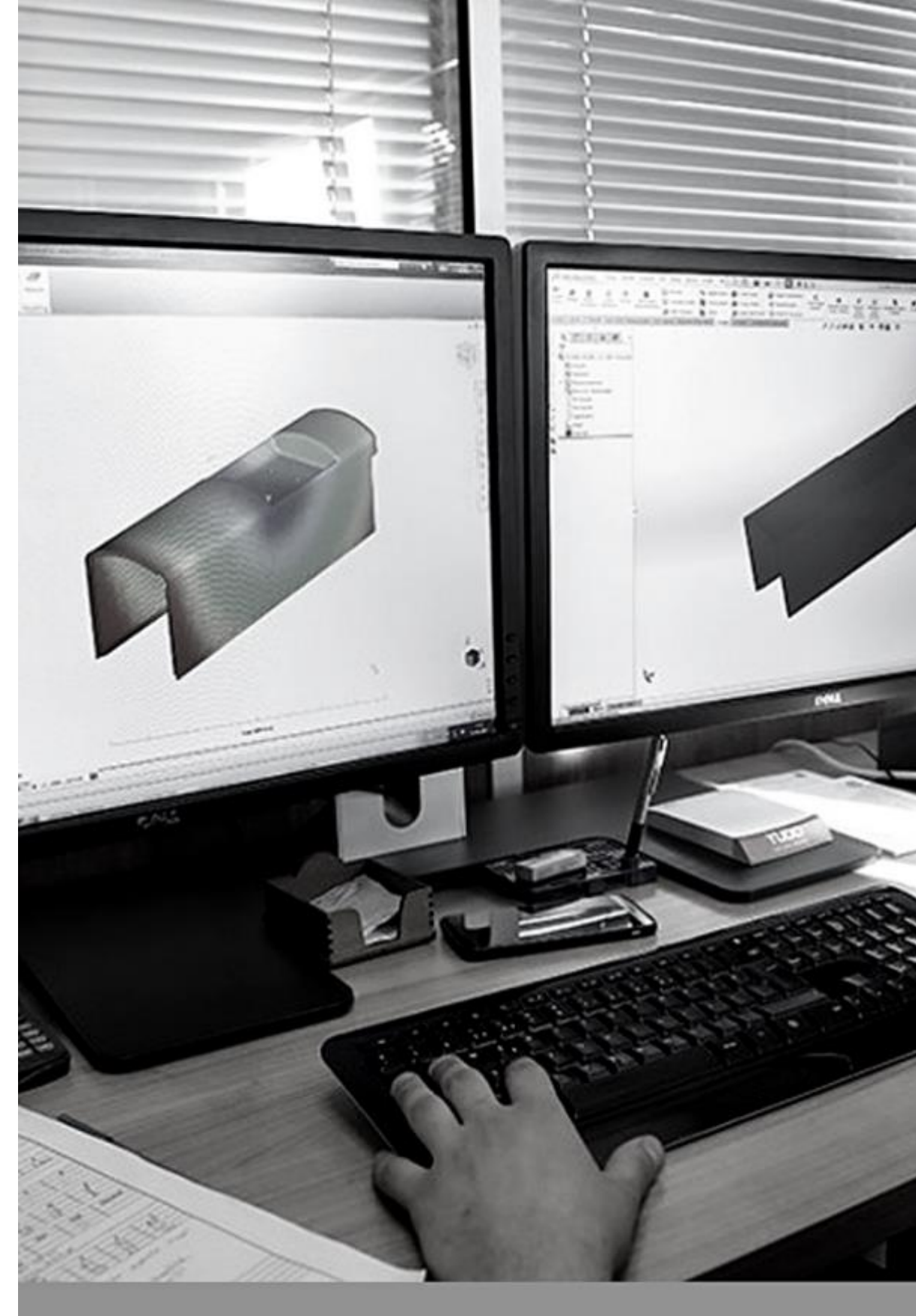

---

## QUALITY CONTROL & REVERSE ENGINEERING

FaroArm Quantum S portable laser scanner is used for quality control of the mould parts and also products. With the help of Geomagic Control X software, FaroArm Quantum S is also have prob control part.

With using Geomagic Design X software, 3D scanned .stl parts can be modified to 3D model.

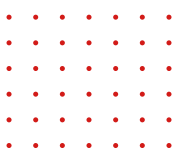
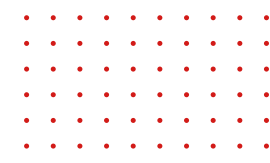
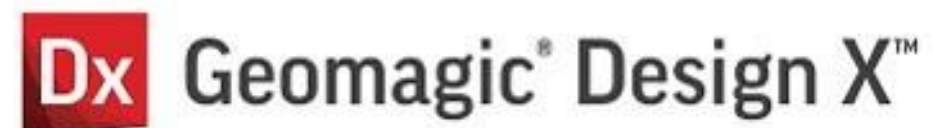

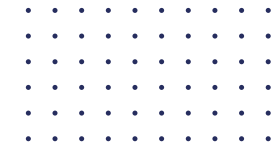
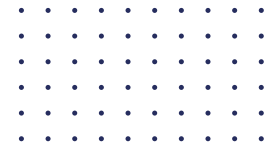

# R&D CAPABILITIES



Siemens NX (Unigraphics)  
SolidWorks + Plastics  
PowerMILL  
Ansys  
Geomagic ControlX  
Geomagic DesignX

4 Licence  
4+1 Licence  
2 Licence  
1 Licence  
1 Licence  
1 Licence



# MACHINERY

<u>MACHINE TYPE</u>	<u>TRADEMARK</u>	<u>QUANTITY</u>	<u>SIZE OF WORKING</u>
<u>CNC</u>	<u>AWEA - LP-3021YZ</u>	<u>1</u>	<u>3000 X 2100 X 1200</u>
<u>CNC</u>	<u>MAXXTRON B14</u>	<u>1</u>	<u>1400 X 1000 X 600</u>
<u>CNC</u>	<u>MAKINO V77</u>	<u>1</u>	<u>1200 X 700 X 700</u>
<u>CNC</u>	<u>MAKINO V77 LONG</u>	<u>1</u>	<u>1500 X 700 X 650</u>
<u>CNC</u>	<u>MAKINO V56</u>	<u>1</u>	<u>900 X 550 X 450</u>
<u>CNC</u>	<u>MAKINO F5</u>	<u>1</u>	<u>900 X 500 X 450</u>
<u>CNC</u>	<u>MAS - MVC1016</u>	<u>1</u>	<u>1000 X 600 X 700</u>
<u>GRAPHITE CNC</u>	<u>MAXXTRON i6</u>	<u>1</u>	<u>600 X 500 X 400</u>
<u>EDM</u>	<u>OSCAR 1050 3R</u>	<u>1</u>	<u>1000 X 500 X 500</u>
<u>EDM</u>	<u>OSCAR S430 3R</u>	<u>1</u>	<u>400 X 300 X 300</u>
<u>WIRE EDM</u>	<u>SPM S64</u>	<u>1</u>	<u>600 X 400 X 350</u>
<u>HOLE EDM</u>	<u>NSD 1000K</u>	<u>1</u>	<u>1050 X 600 X 640</u>
<u>GRINDING</u>	<u>PROTH</u>	<u>1</u>	<u>800 X 400 X 300</u>
<u>RADIAL</u>	<u>INVEMEA</u>	<u>1</u>	<u>1000 X 600</u>
<u>LATHE</u>	<u>TOS UNIVERSAL</u>	<u>1</u>	<u>1000</u>

# DIE CASTING EXAMPLE

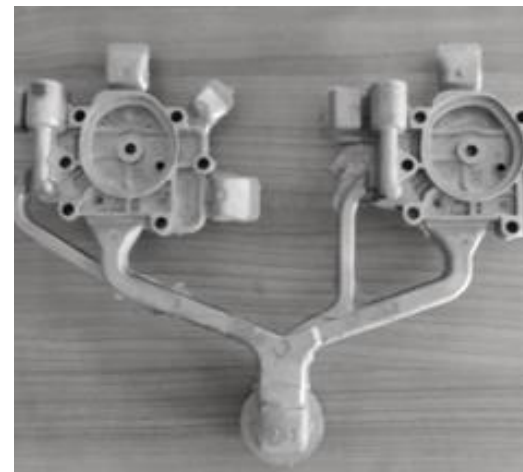
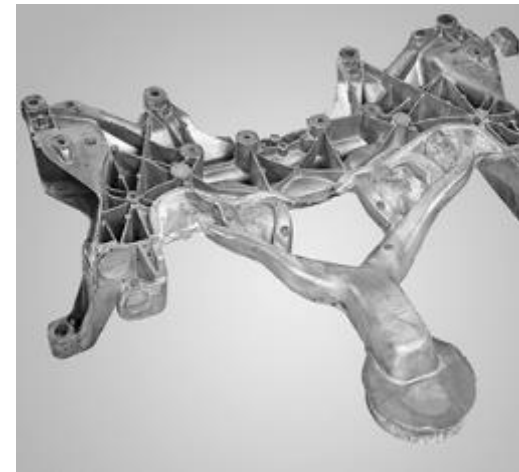
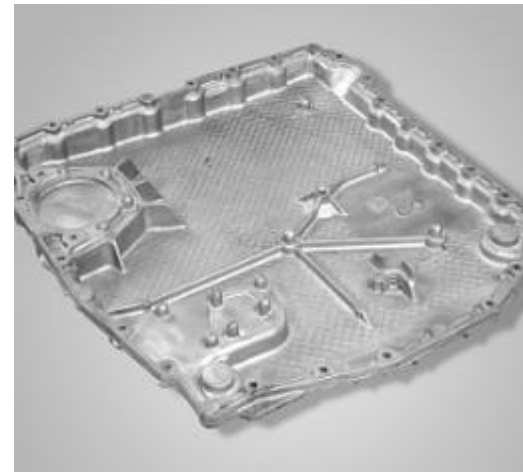
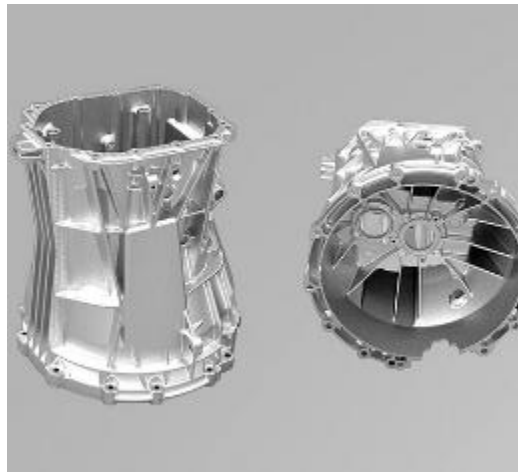
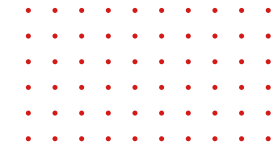
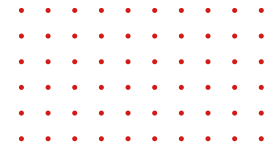

# DIE CASTING GLOBAL BRANDS



**CORE OF THE GLOBAL  
AUTOMOTIVE BRANDS**

 <b>SCANIA</b>	 <b>VOLVO</b>	 <b>RENAULT</b>	 <b>BMW</b>	 Mercedes-Benz
 PORSCHE	 <i>Ford</i>	 <b>Audi</b>	 <b>VW</b>	 <b>Togg</b>

# HPDC MOLD EXAMPLE

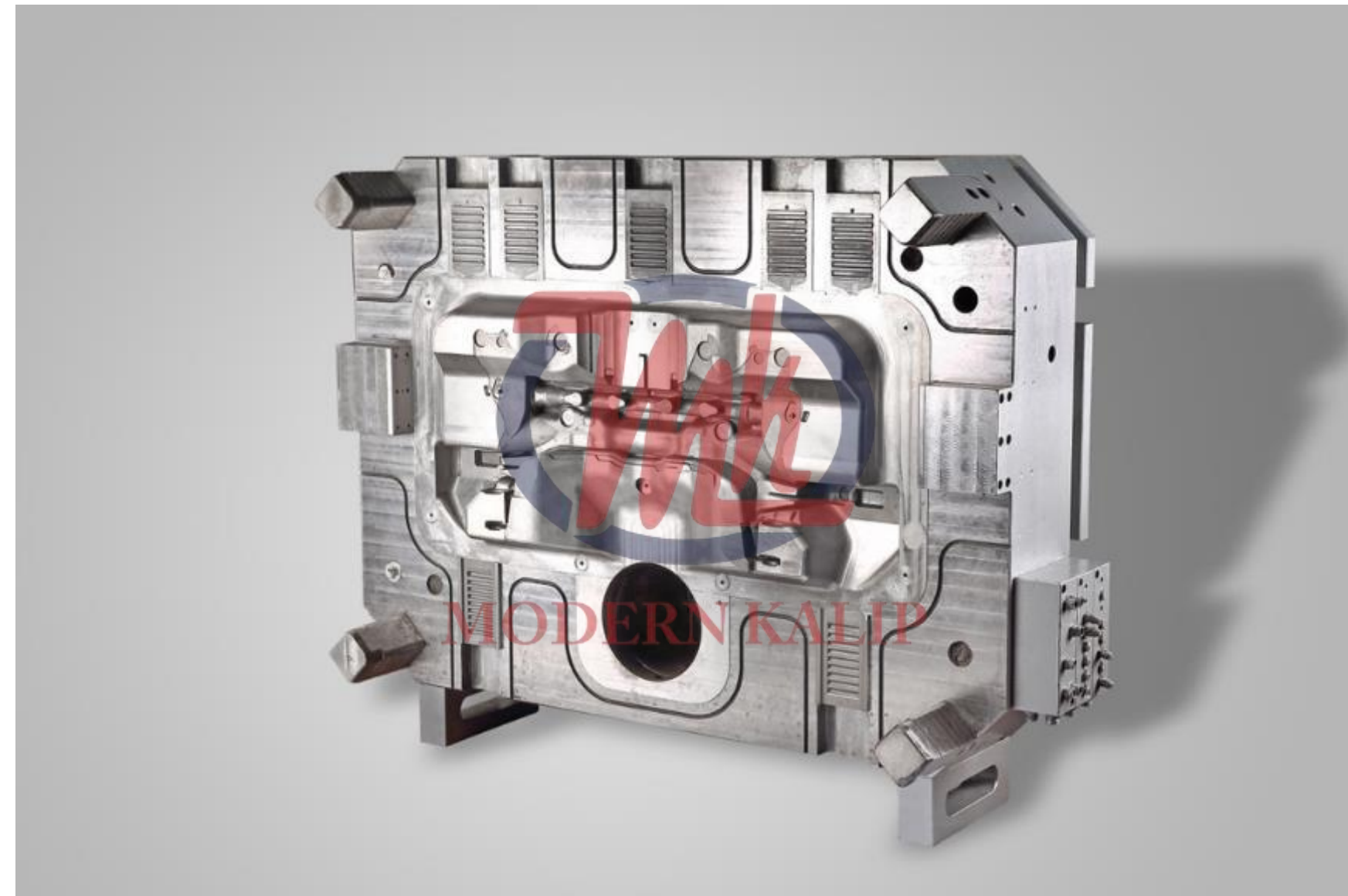
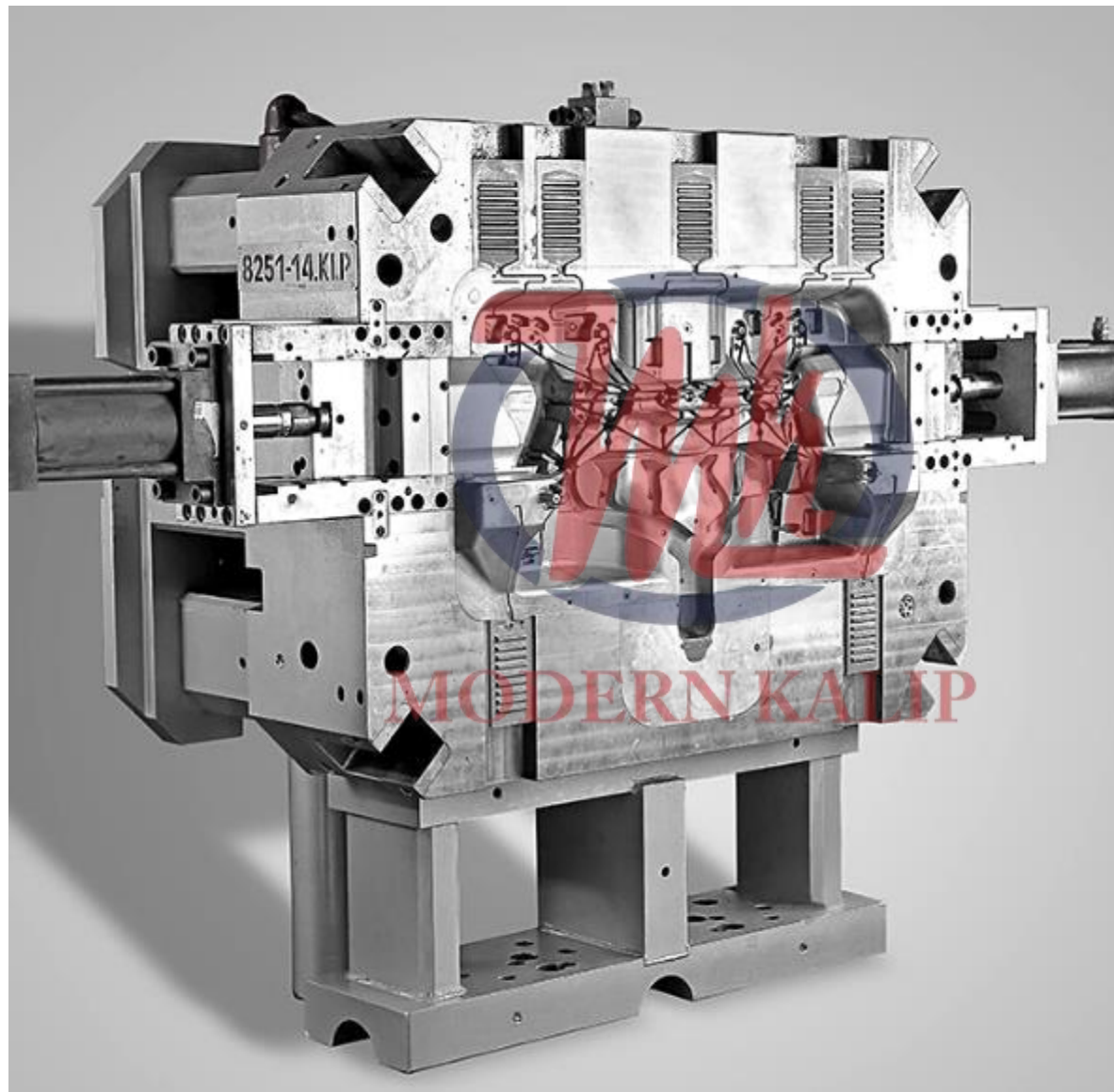

\*3000 T PRESS  
MACHINE

\*27 T TOOL  
WEIGHT

# HPDC MOLD EXAMPLE

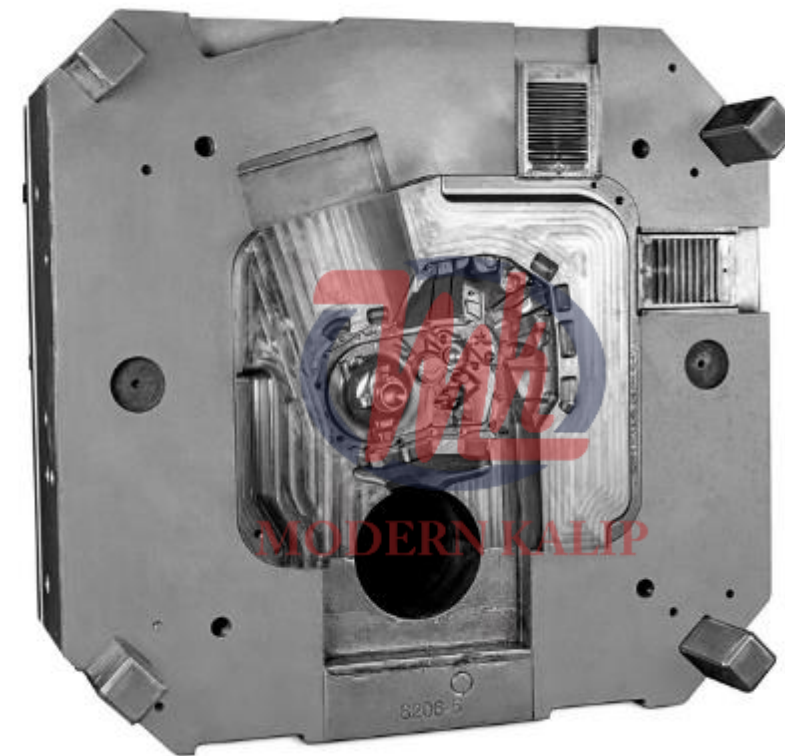
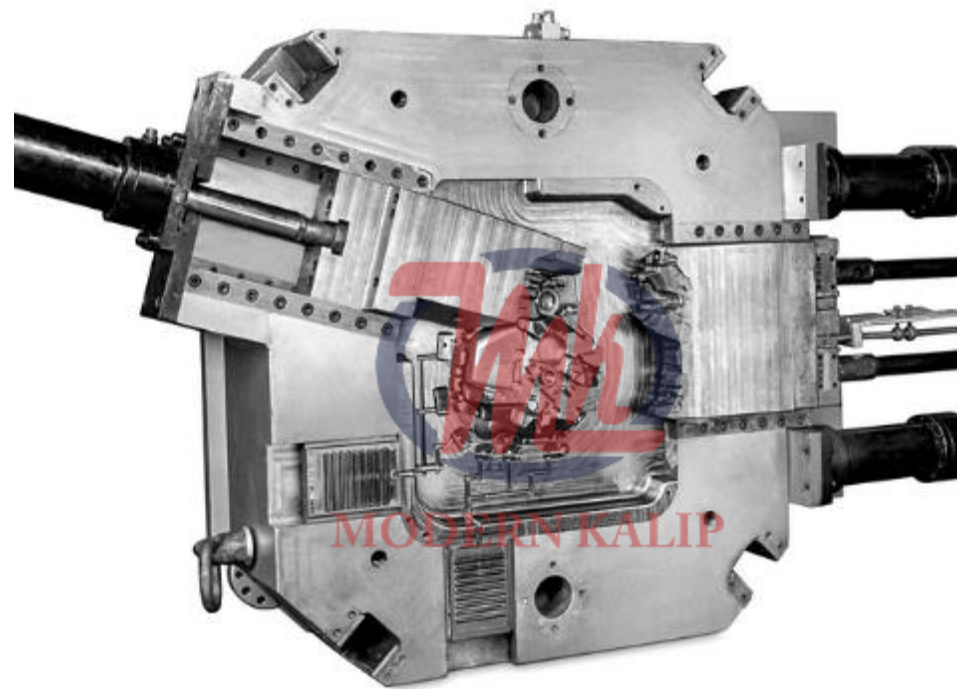

\*16 T TOOL  
WEIGHT

\*1490\*1400\*1000  
TOOL DIMENSION

# HPDC MOLD EXAMPLE

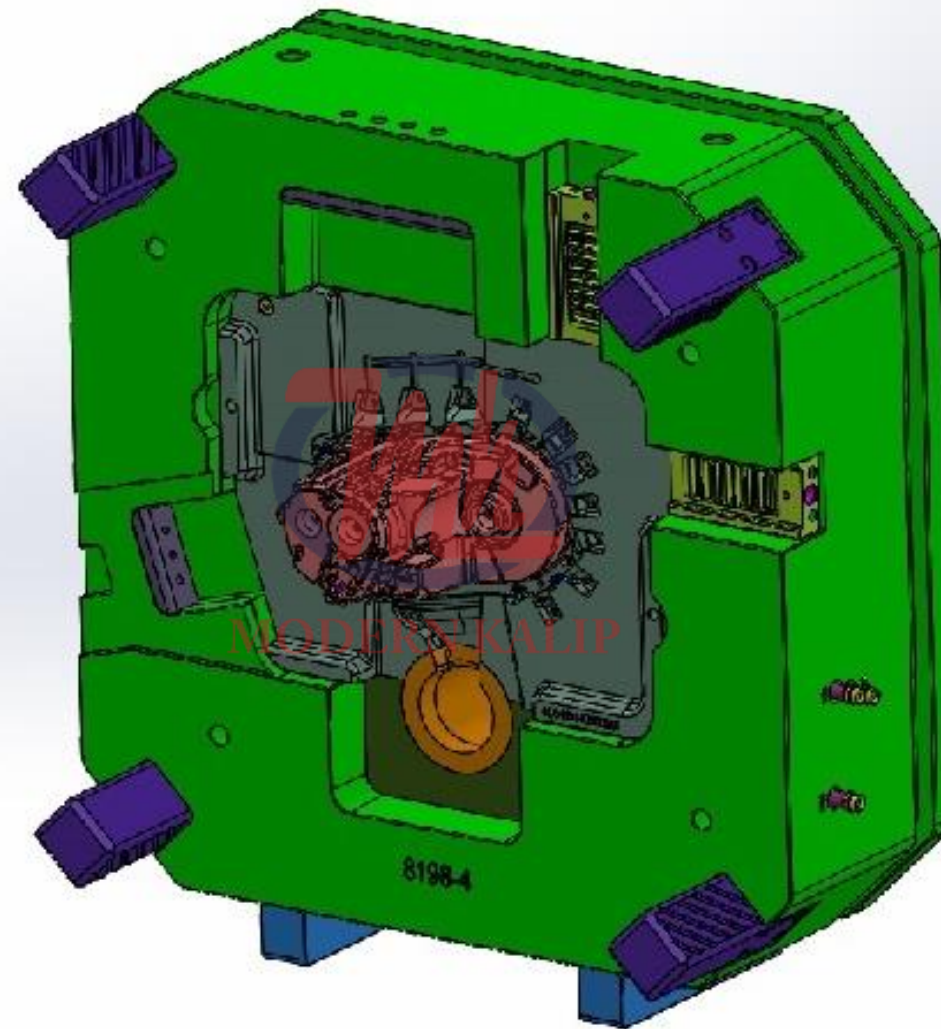
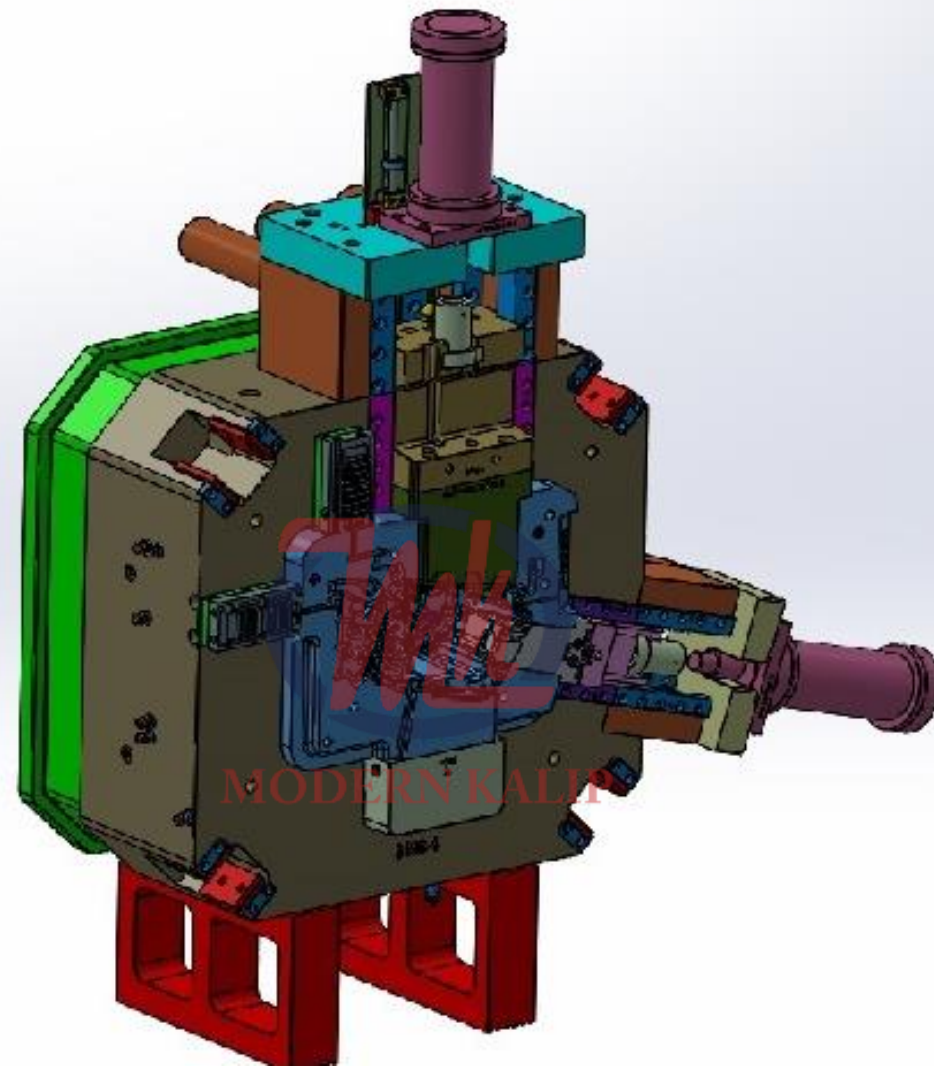

\*15 T TOOL  
WEIGHT

\*1350\*1300\*1000  
TOOL DIMENSION

# HPDC MOLD EXAMPLE

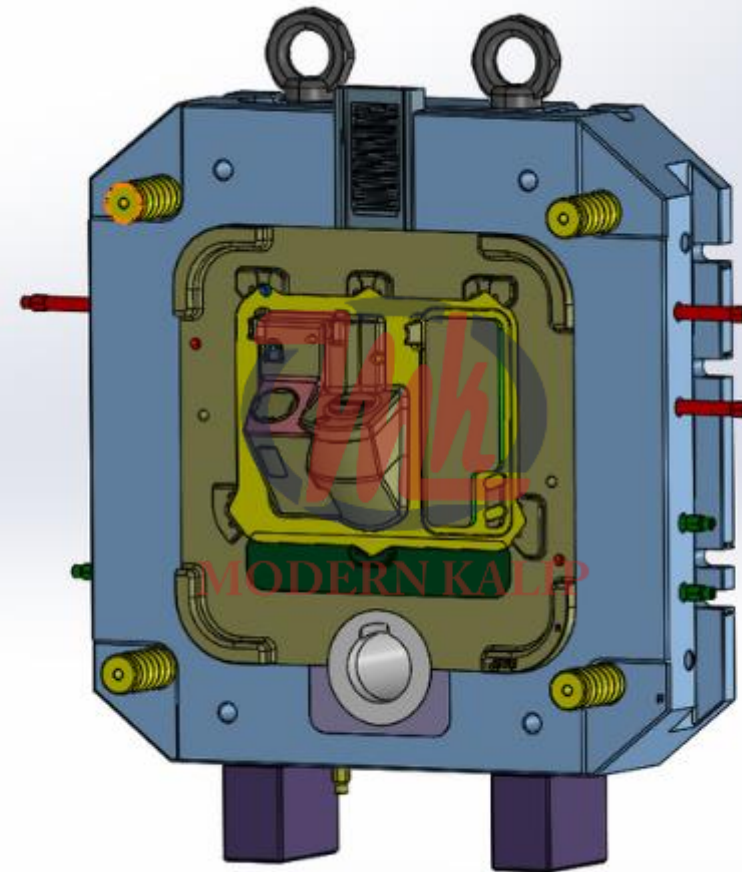
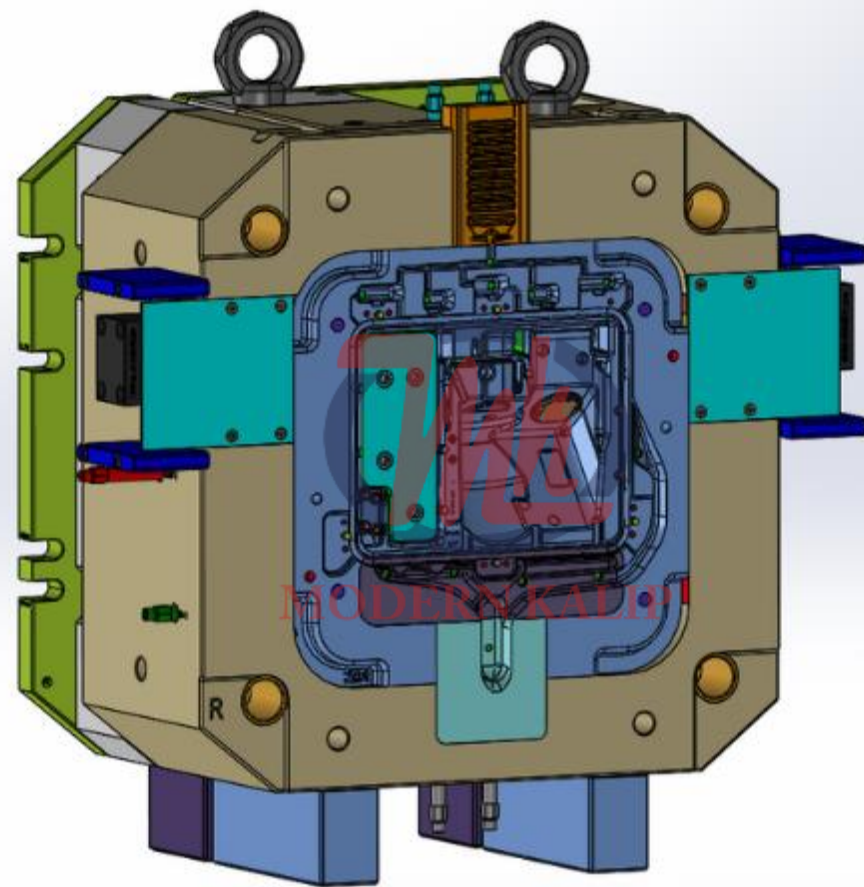

\*1100 T PRESS

\*5 T TOOL WEIGHT

\*1200\*1150\*390  
TOOL DIMENSION

# HPDC MOLD EXAMPLE

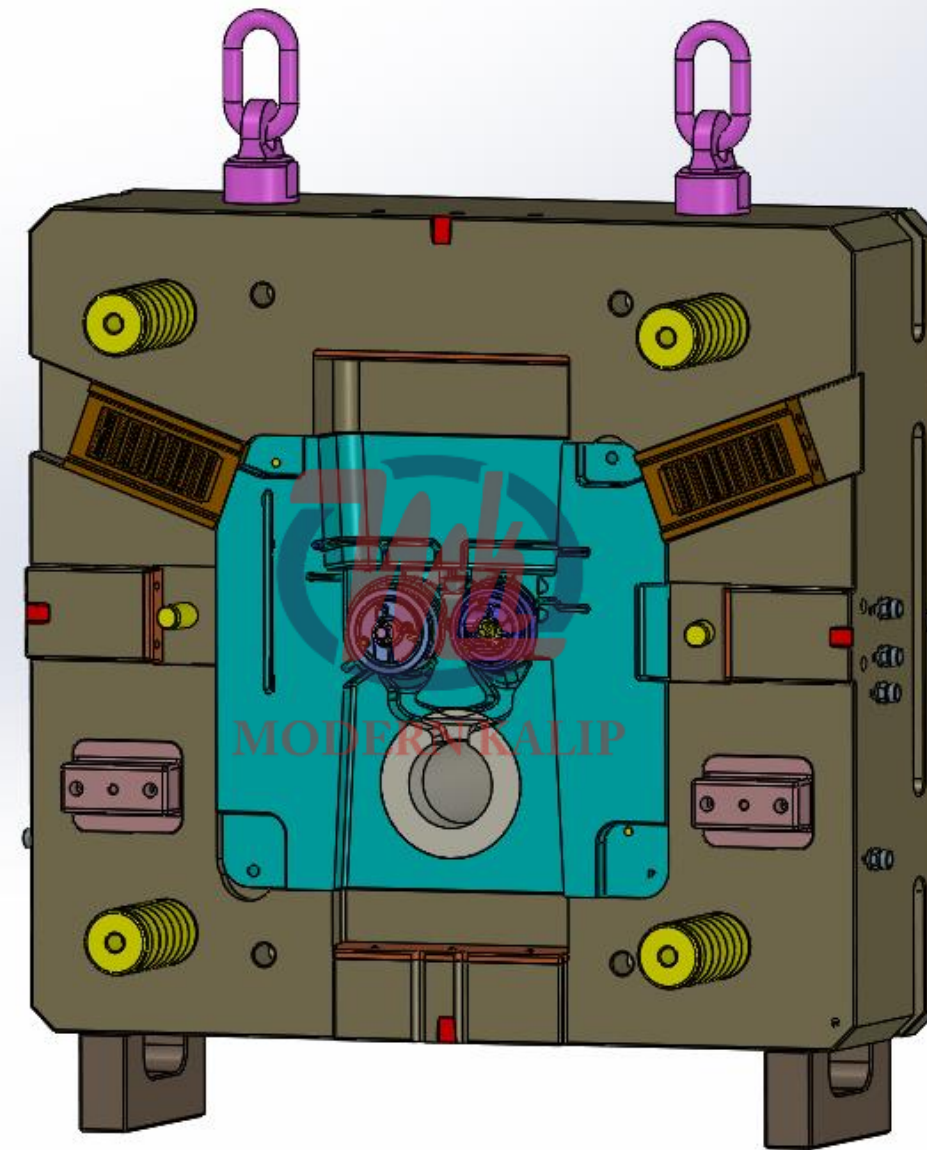
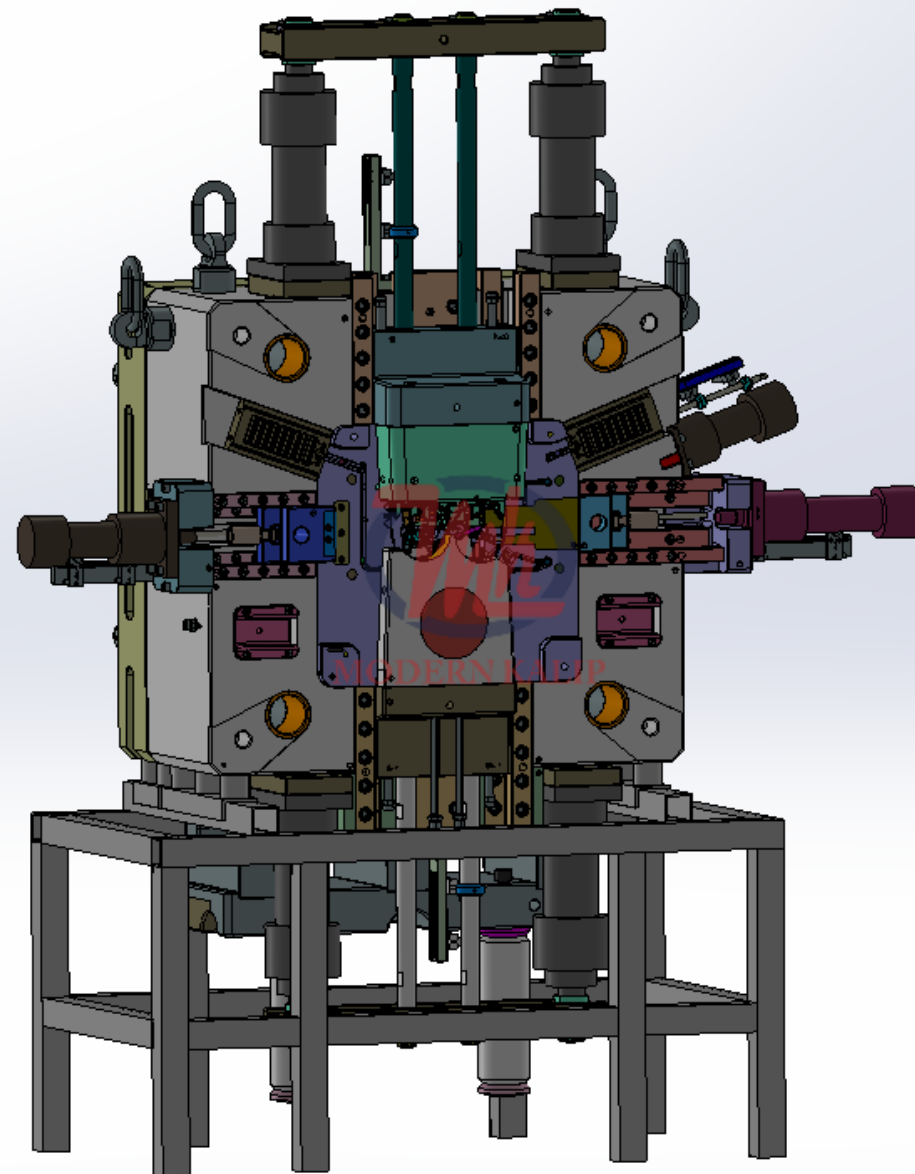

\*1650 T PRESS

\*8 T TOOL WEIGHT

\*1980\*2300\*1550  
TOOL DIMENSION

# HPDC MOLD EXAMPLE

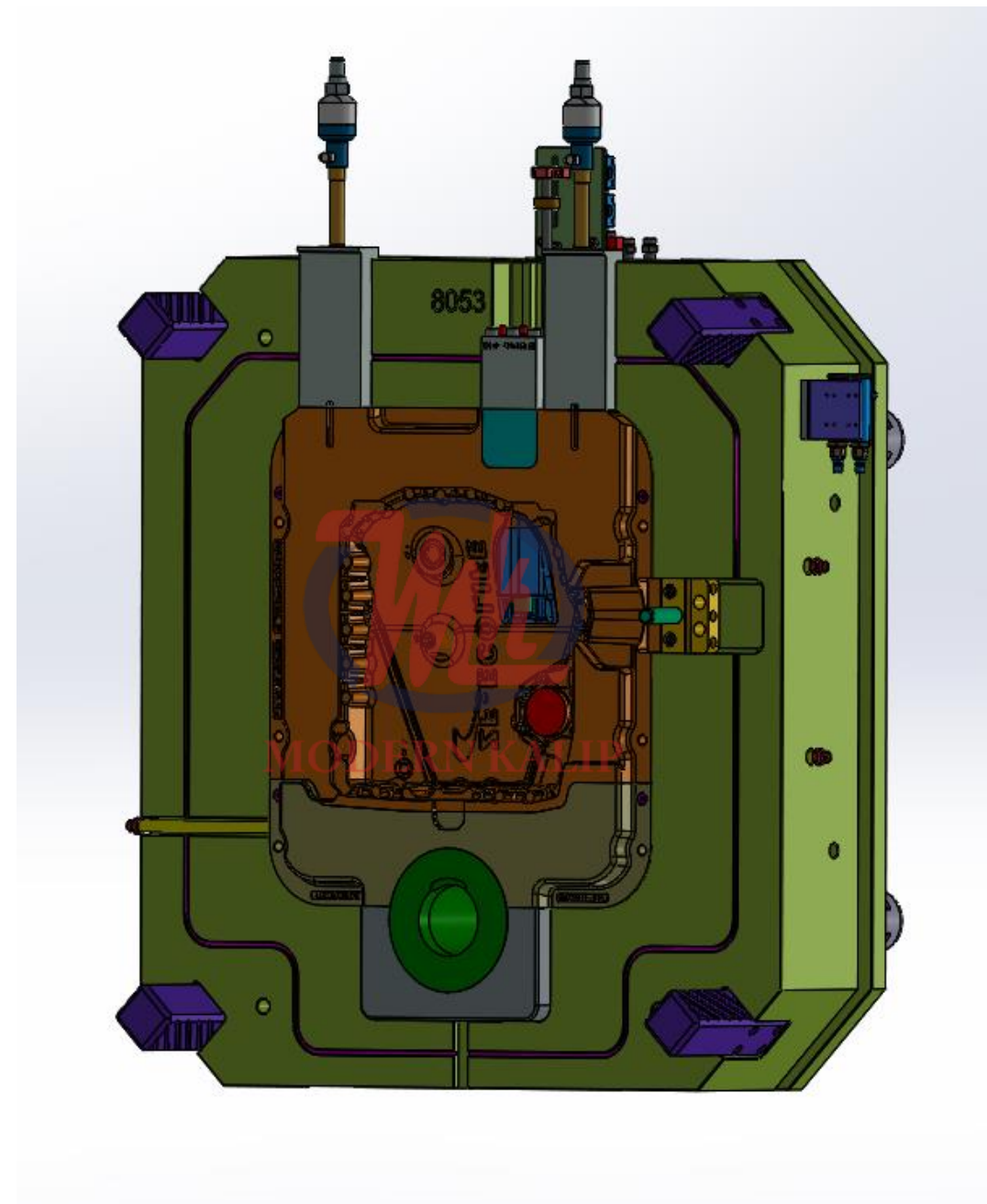
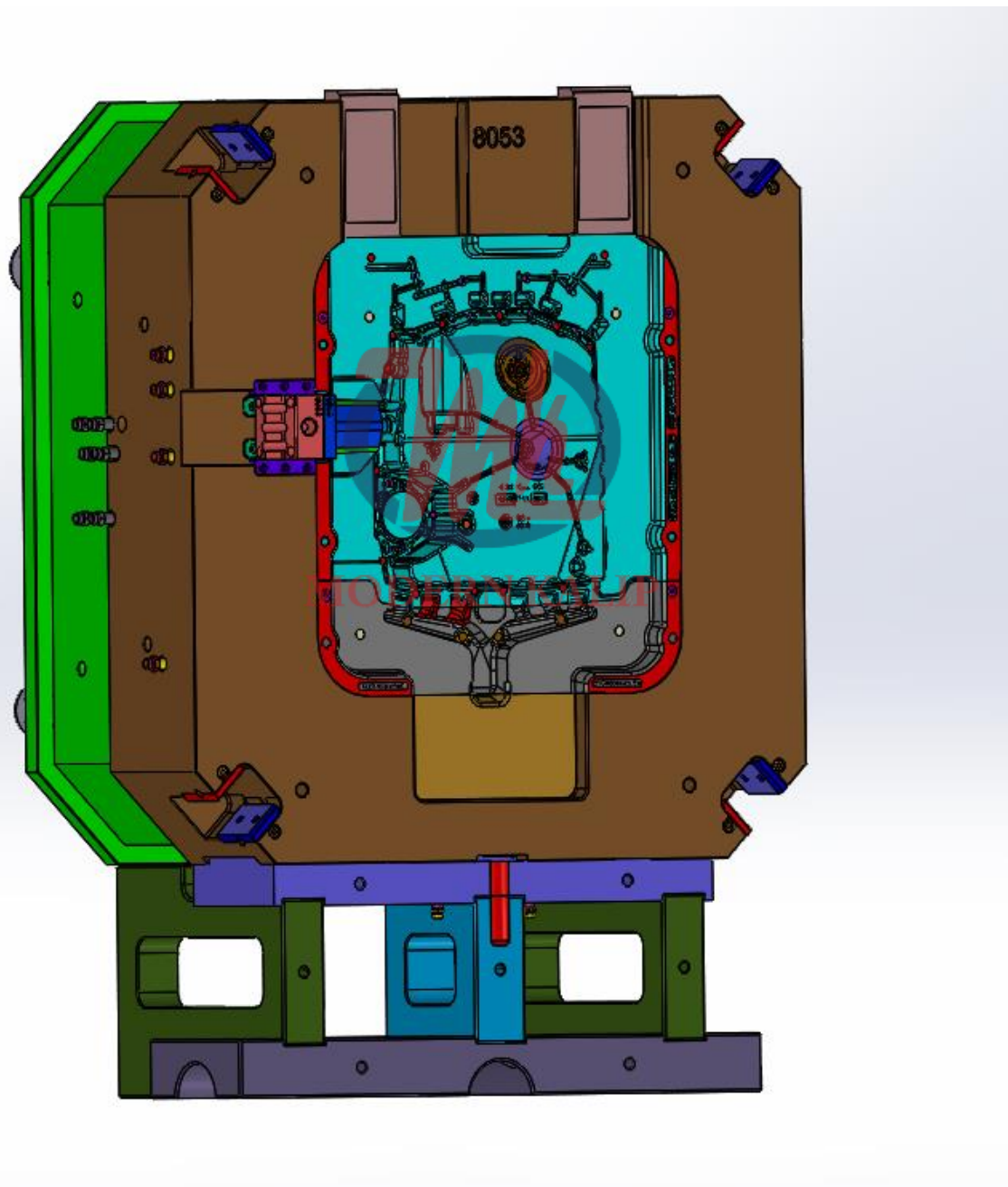

\*20 T TOOL  
WEIGHT

\*1465\*2045\*1000  
TOOL DIMENSION

# HPDC MOLD EXAMPLE

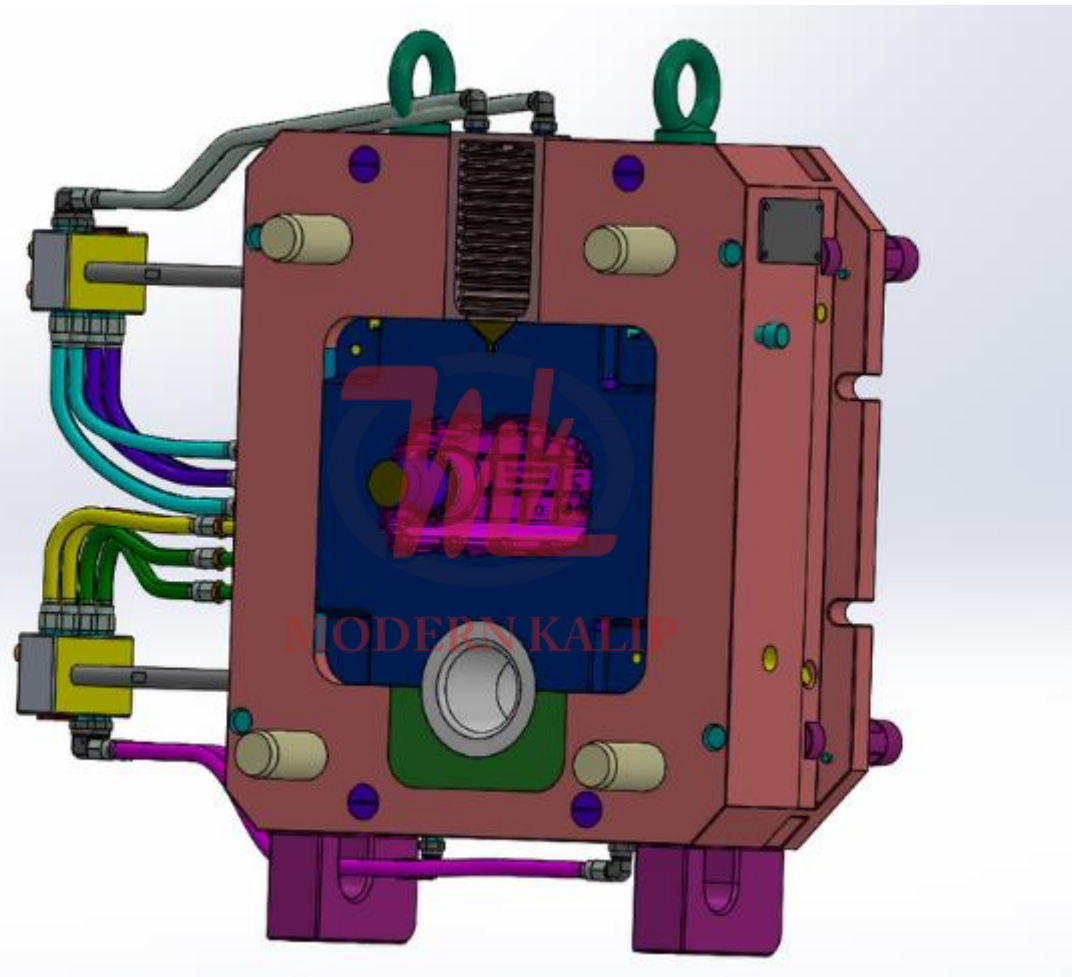
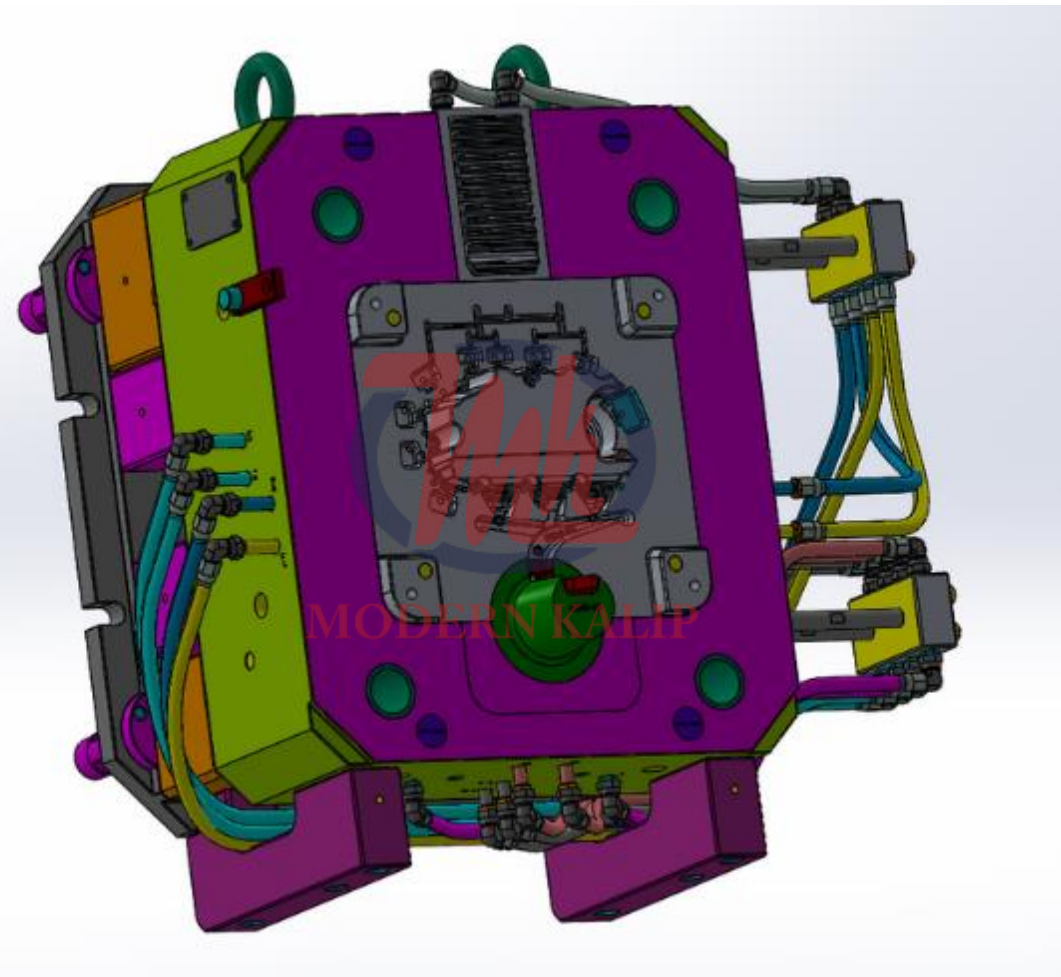

\*11 T TOOL  
WEIGHT

\*850\*1000\*750  
TOOL DIMENSION

# LPDC MOLD EXAMPLE

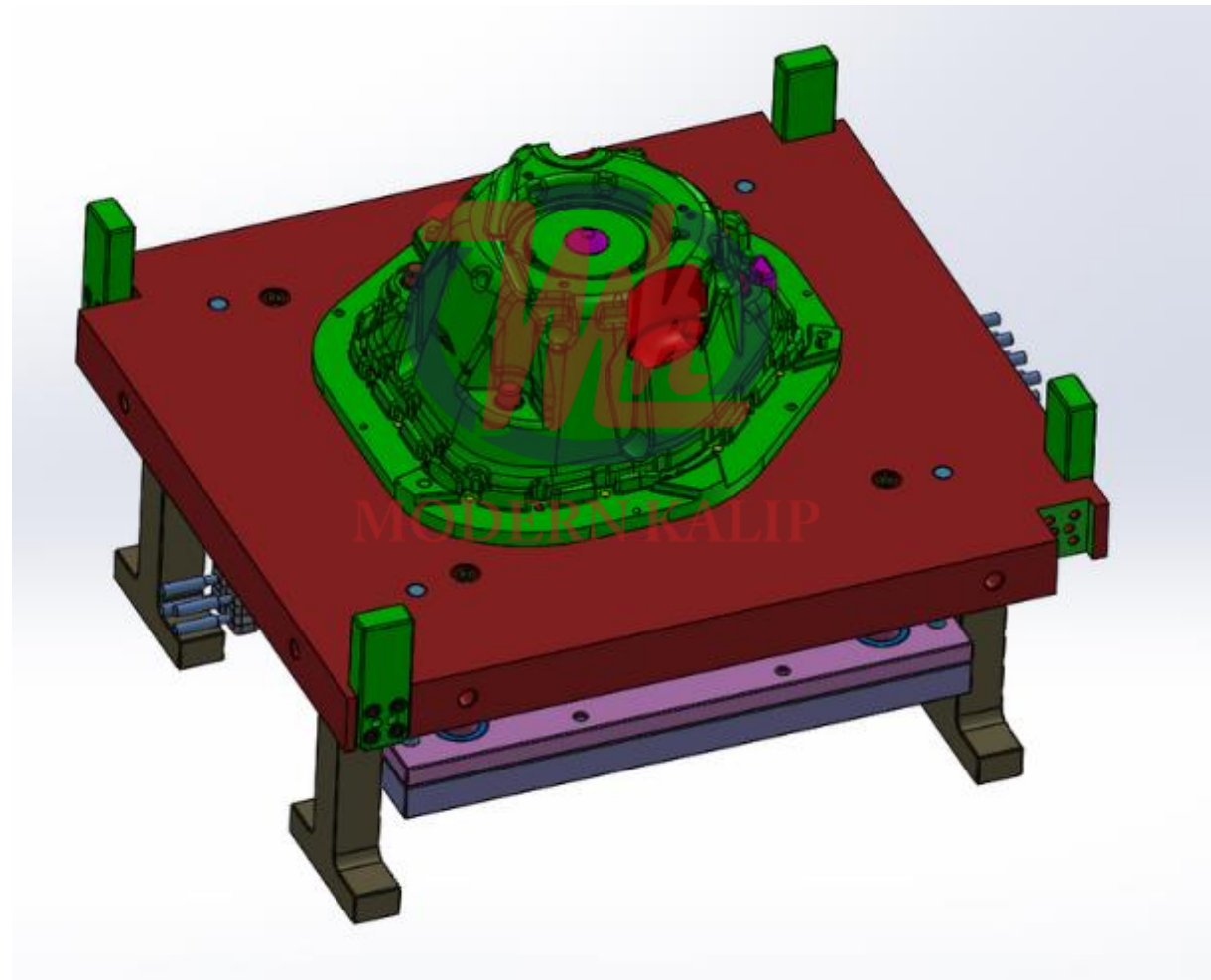
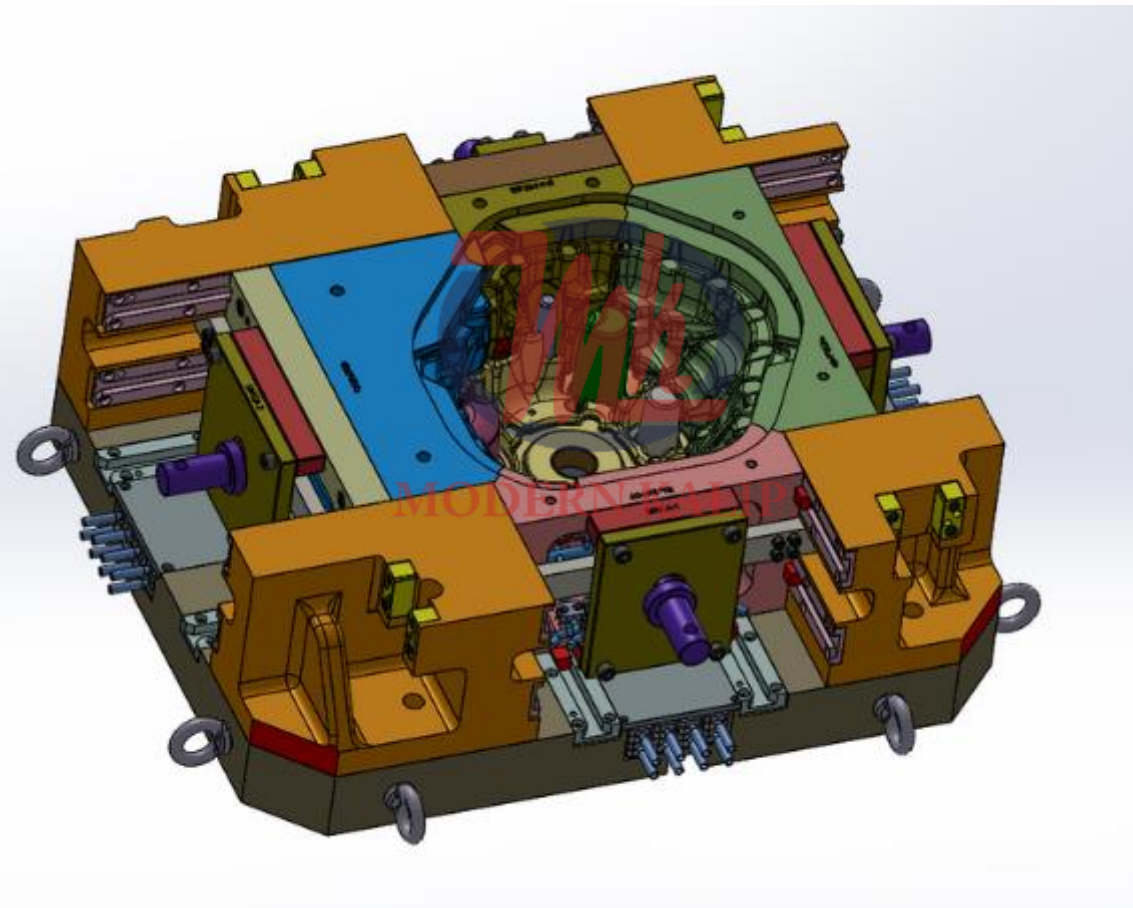

\*1200\*1100\*400  
LOWER SIDE TOOL  
DIMENSION

\*1200\*1100\*640  
UPPER SIDE TOOL  
DIMENSION

# LPDC MOLD EXAMPLE

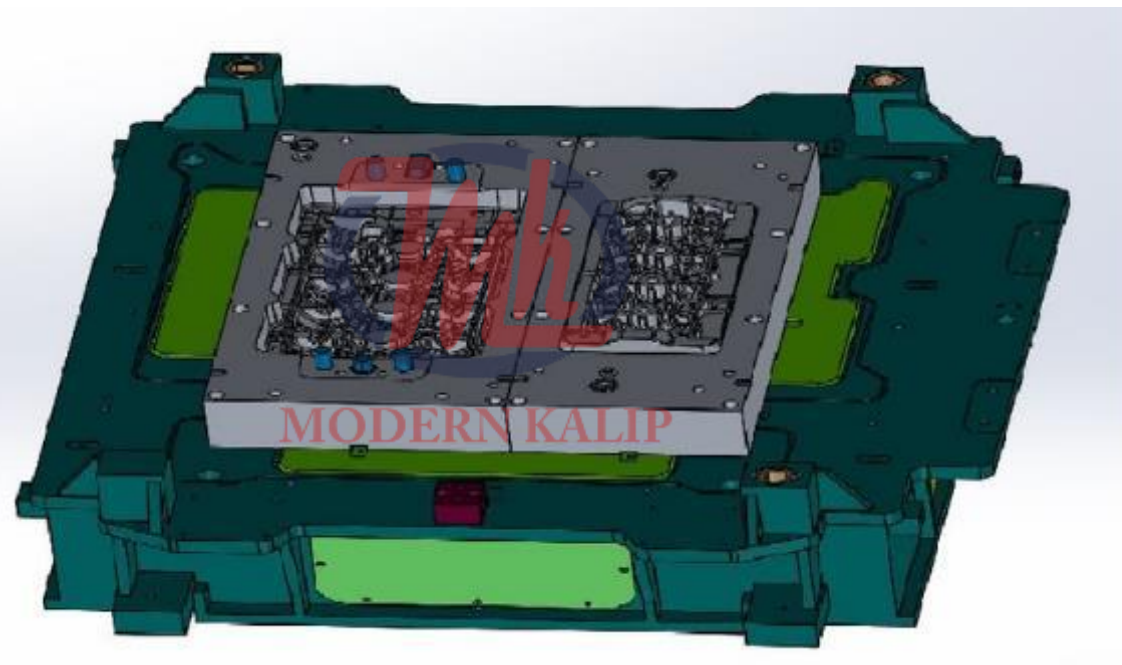

\*3 T TOOL  
WEIGHT

\*1290\*1245\*570  
TOOL DIMENSION

# LPDC MOLD EXAMPLE

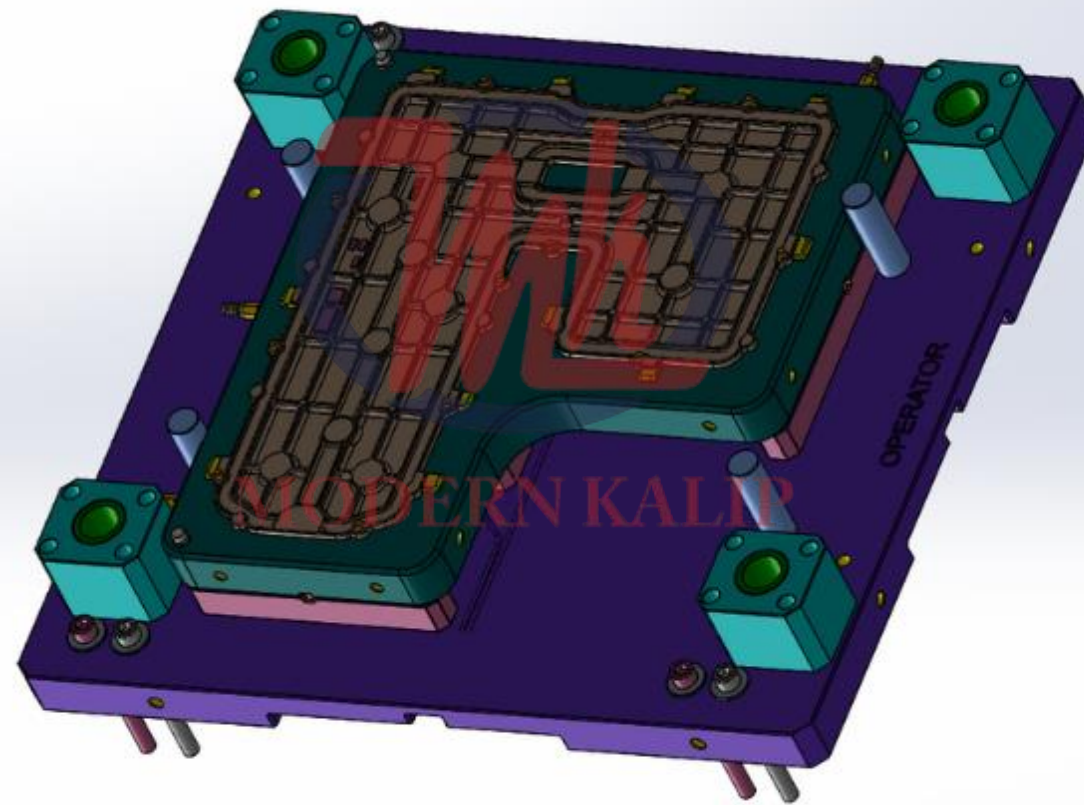
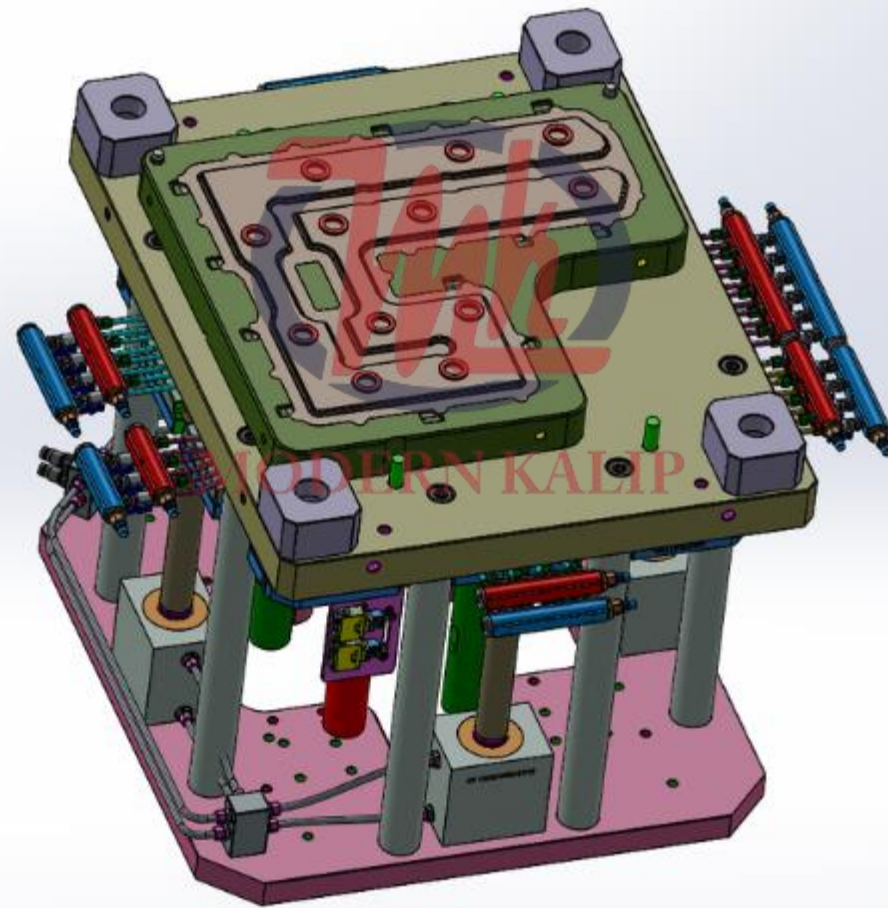

\*1120\*1145\*1000  
UPPER TOOL  
DIMENSION

- 1120\*1145\*210
- LOWER TOOL  
DIMENSION

# LPDC MOLD EXAMPLE

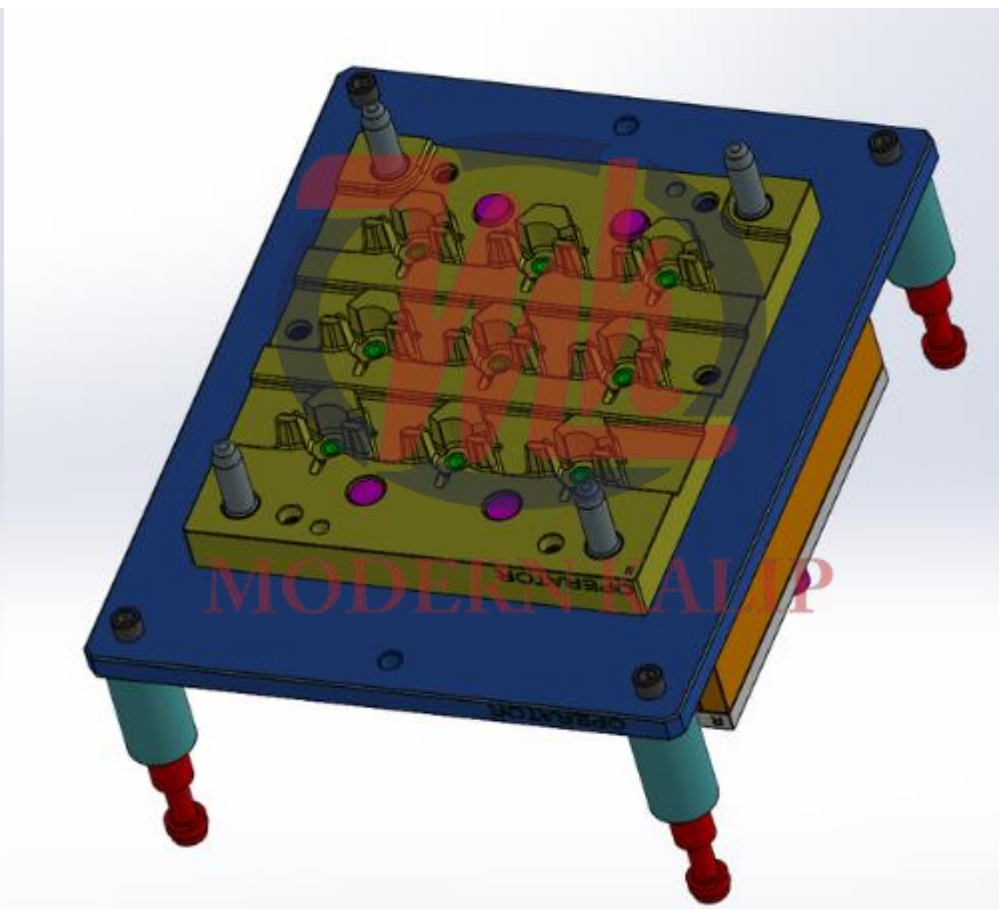
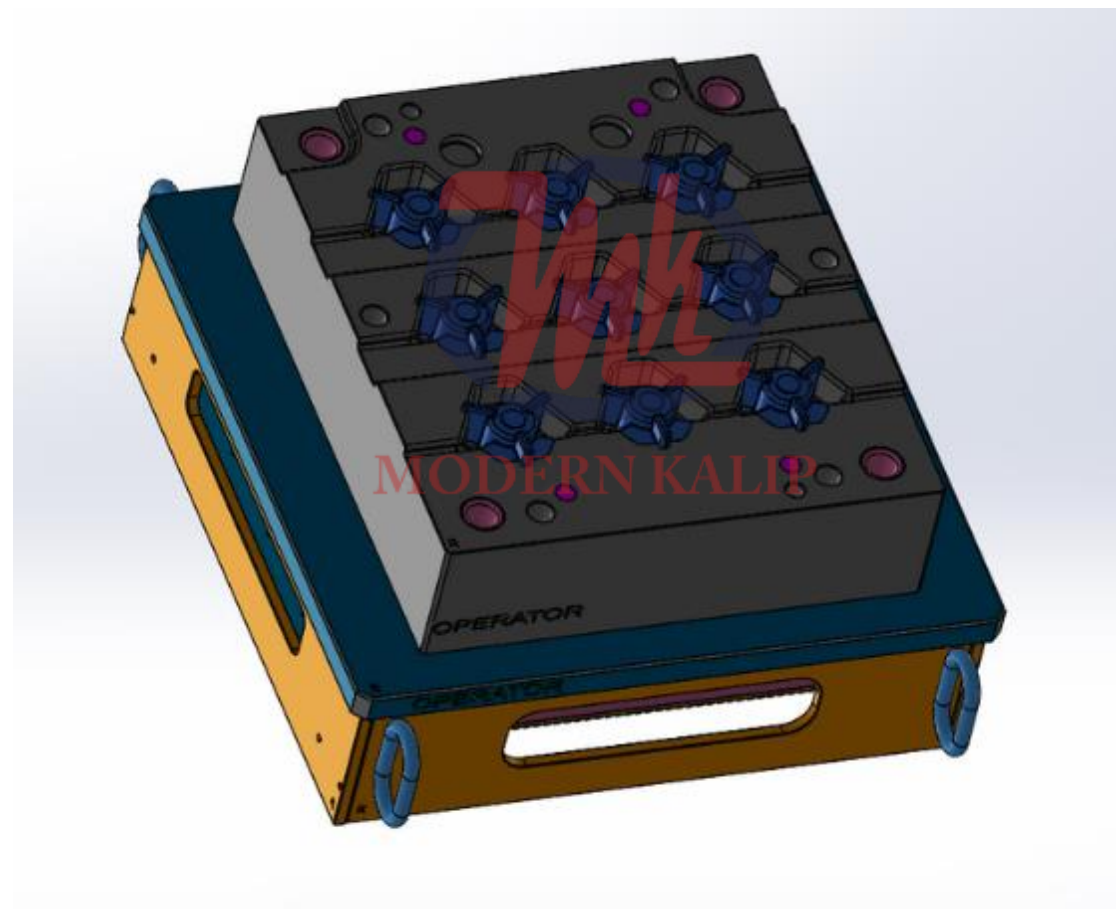
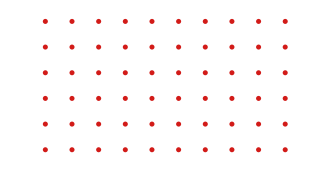
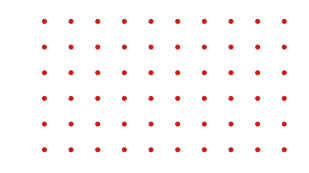

\*665\*520\*225  
UPPER TOOL  
DIMENSION

\*520\*520\*275  
LOWER TOOL  
DIMENSION

# LPDC MOLD EXAMPLE

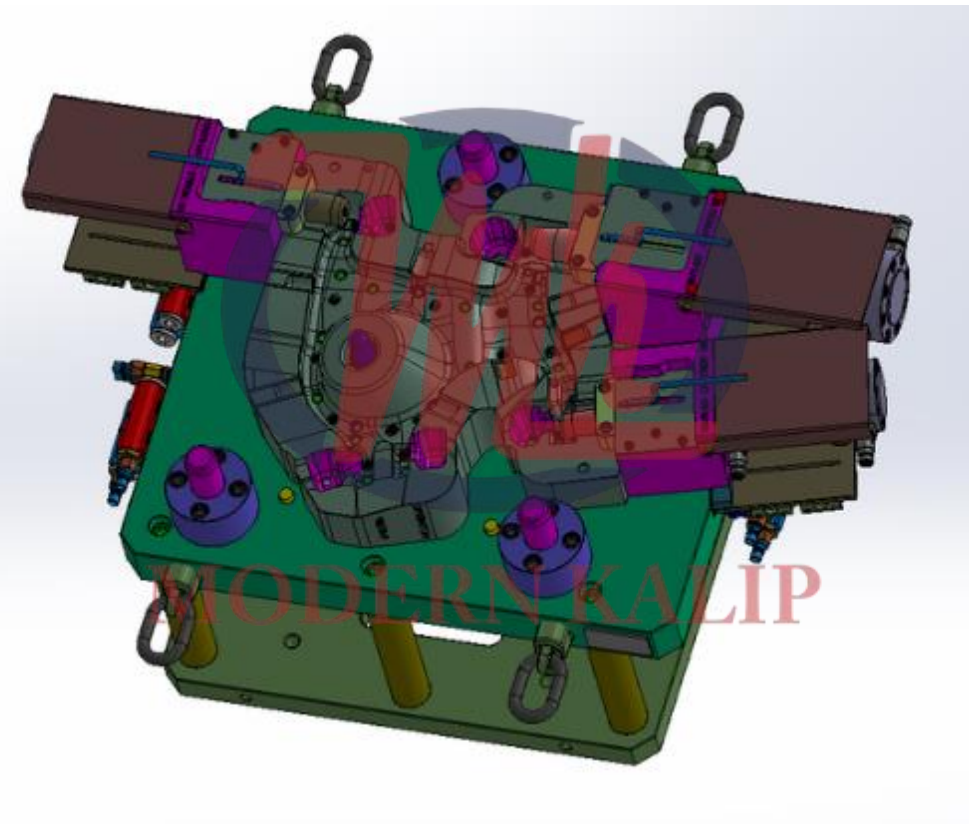
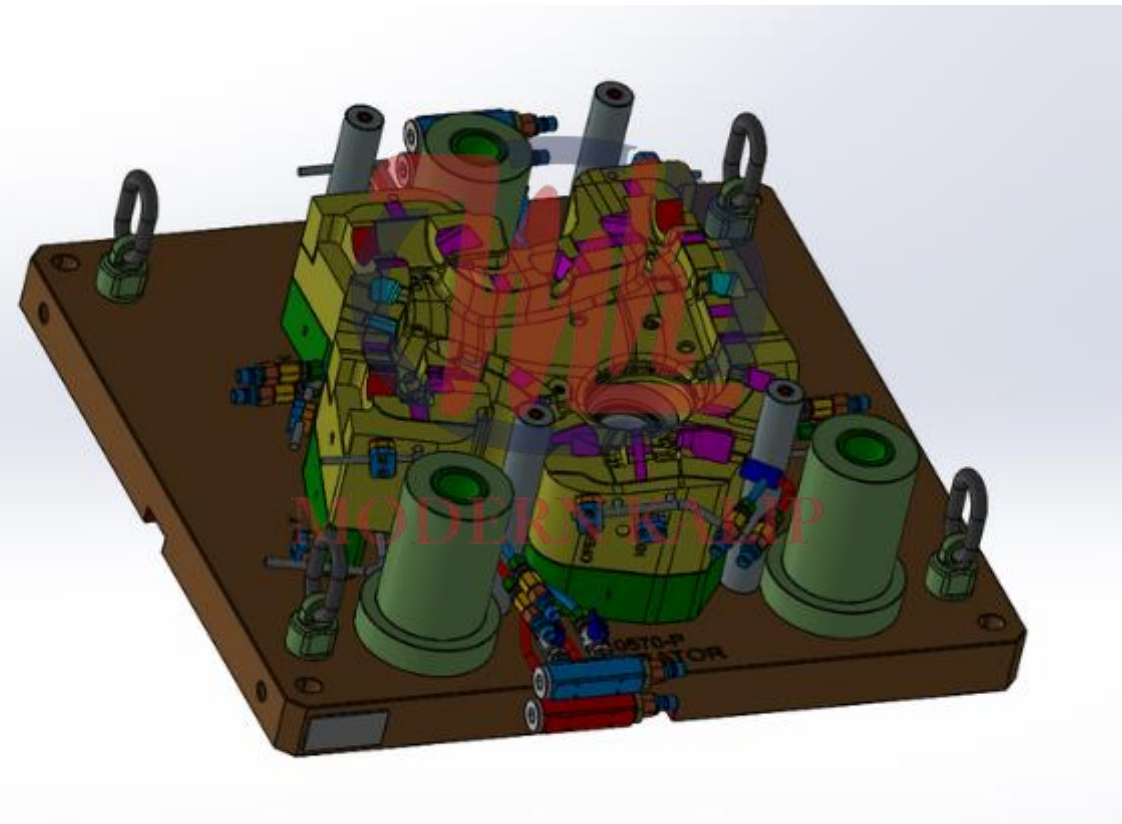

\*2 T TOOL WEIGHT

\*1380\*870\*775  
TOOL DIMENSION

# PLASTIC INJECTION EXAMPLE

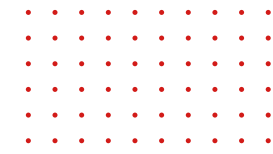
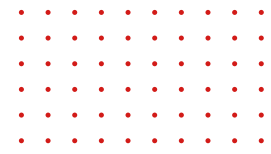

# PLASTIC INJECTION MOLD EXAMPLE

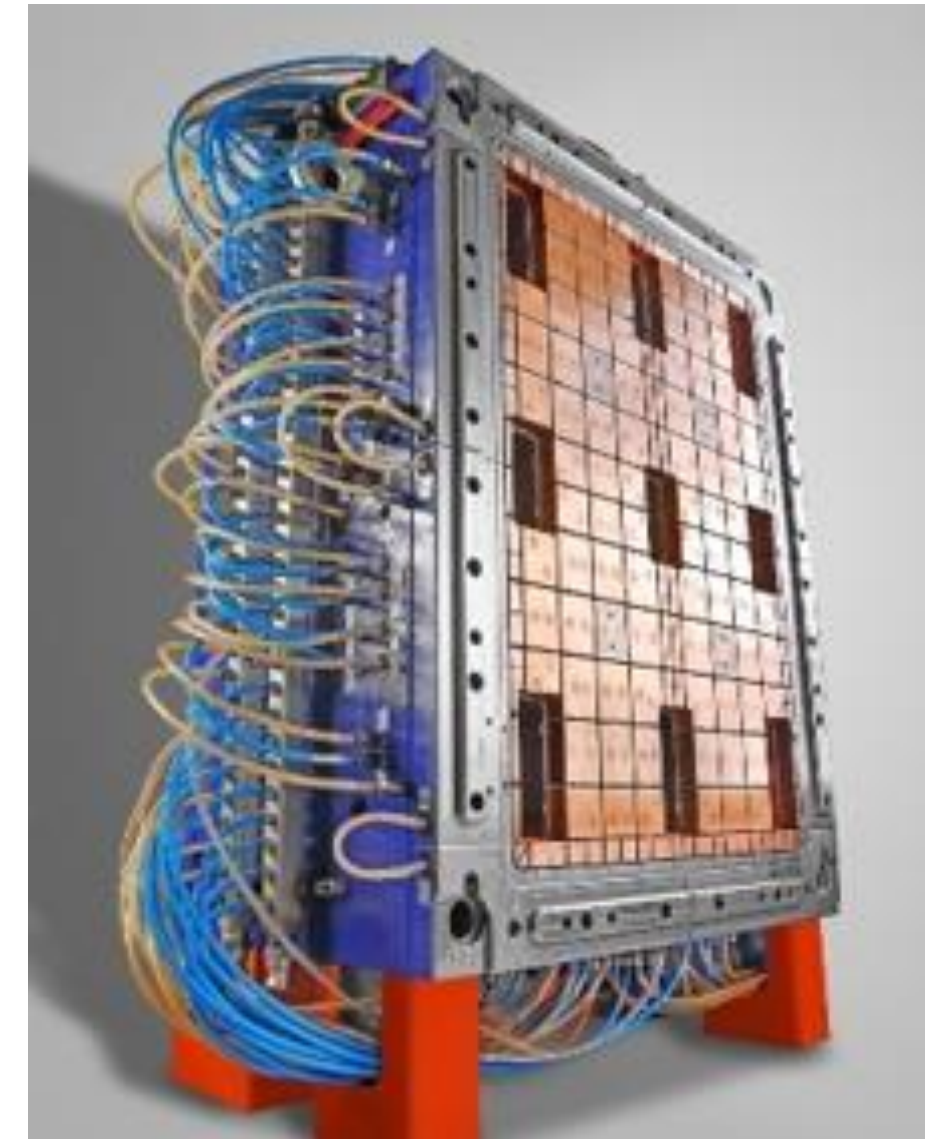
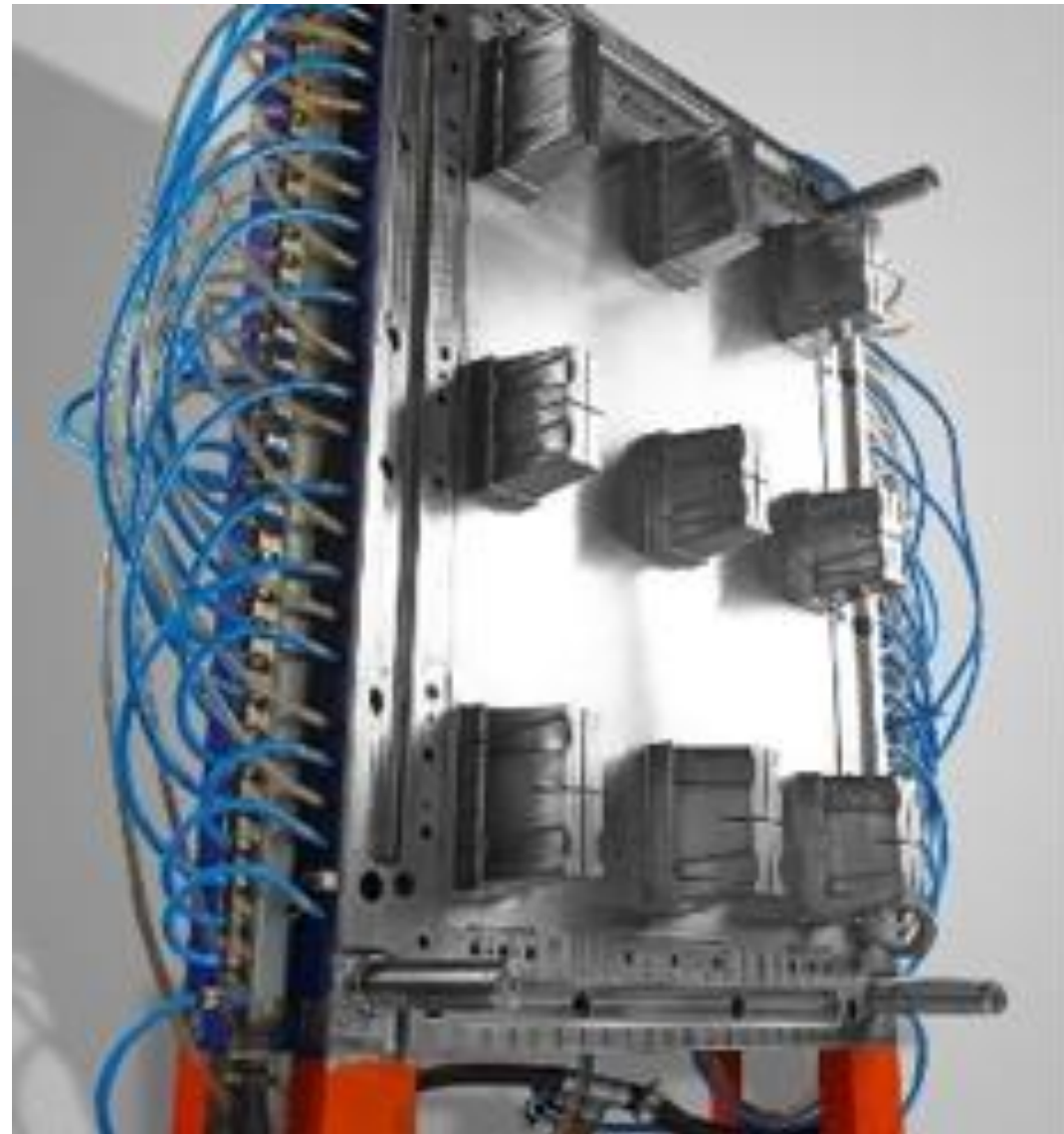
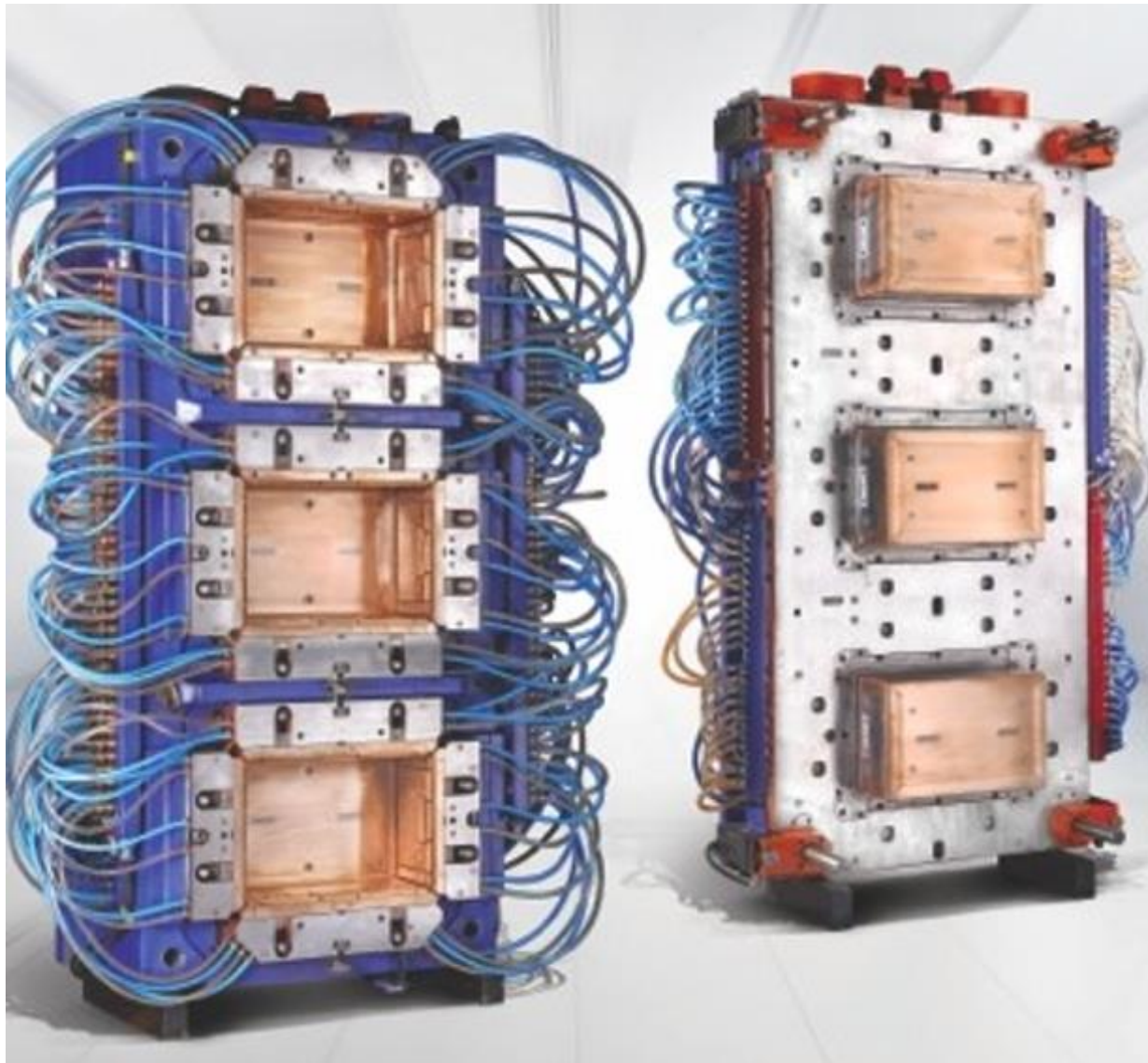

# FAIRS ATTENDED

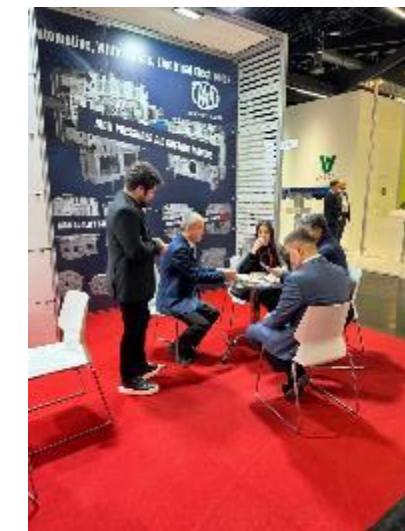
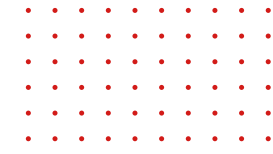
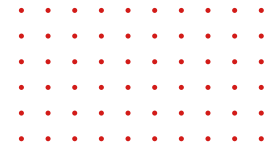

**VISIT US AT  
EUROGUSS 2026  
AT HALL 5- 354**



# REFERENCES





MODERN KALIP

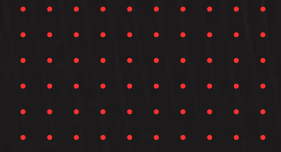

# FORMING YOUR IDEAS

[www.modernkalip.com](http://www.modernkalip.com)

---



COMPANY PRESENTATION