



Light Weight Deflectometer PRODUCT RANGE 2026

according to ASTM E2835-11 and german standard TP BF-StB Part B 8.3



MINIMUM REQUIREMENTS

A vertical bar with icons and text. From top to bottom: a truck icon with '>25', a car icon with '>40', a bicycle icon with '>40', a house icon with '>40', a person walking icon with '>40', and a person with a cane icon with '>65'. Below these is a red section with a white warning triangle and a person with a cane icon.

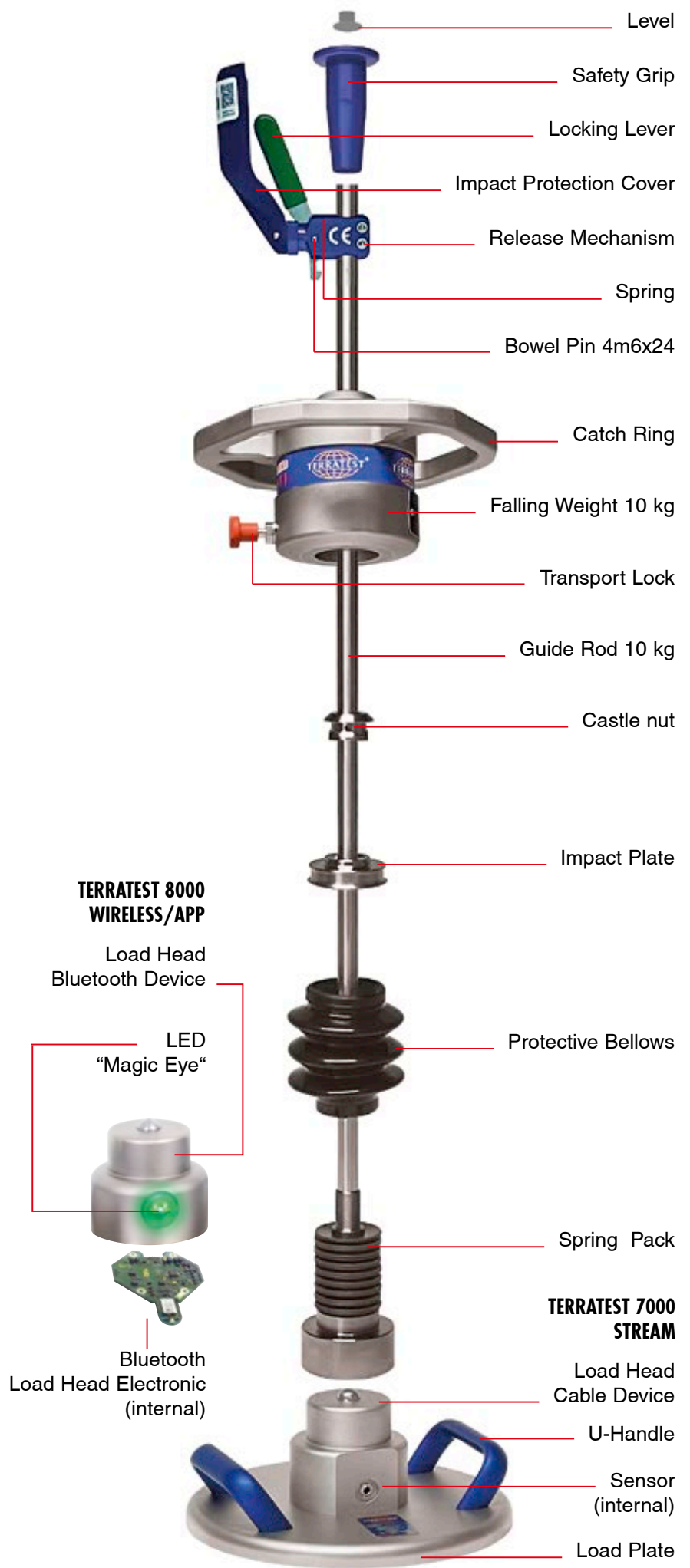

International Standards

TERRATEST® equipment approved all over the world



ASTM E2835-11

American Standard Test Method for Measuring Deflections using a Portable Impulse Plate Load Test Device



TP BF-StB part B 8.3 edition 2012

German regulation: Engineering Code for Soil and Rock in Road Construction



RIL 836, Deutsche Bahn AG (German railway)

Guideline for the use of the measuring equipment in railway construction



RVS 08.04.04 (March 2008)

Austrian regulation – Compaction test by means of dynamic plate load test



VSS 70 313 (July 2019)

Swiss regulation – Compaction test by means of dynamic plate load test



SB 250 versie 4.1, 4.16.2 (April 2019)

Belgian regulation – Compaction test by means of dynamic plate load test



UNE 103807-2:2021

Spanish regulation – Plate Load Test by means of the measuring equipment – part 2



TB 10001-2016

Chinese regulation – Design Guidelines Railroad Substructure



ČSN 736192 – 1996

Czech regulation – Design Guidelines Railroad Substructure



Test Method Q258A 2021

Australian regulation – Dynamic modulus of deformation – light falling weight device – accelerometer type

Content

The "Every Day One" TERRATEST 7000 STREAM (Cable) with Smartphone APP	4
The "Every Day One" ALL-INCLUSIVE-SET: TERRATEST 7000 STREAM (Cable)	6
The "Every Day One" TERRATEST 8000 APP (BLUETOOTH®) with Smartphone APP	8
The "Every Day One" ALL-INCLUSIVE-SET: TERRATEST 8000 APP (BLUETOOTH®)	10
The "Every Day One" TERRATEST 8000 WIRELESS (BLUETOOTH®) with Smartphone APP	12
The "Every Day One" ALL-INCLUSIVE-SET: TERRATEST 8000 WIRELESS (BLUETOOTH®)	14
The "Slim One" For narrow fiber-optic trenches: TERRATEST 7000 TRENCH® (Cable)	16
The "Slim One" For narrow fiber-optic trenches: ALL-INCLUSIVE-SET: TERRATEST 7000 TRENCH®	18
The "Slim One" For narrow fiber-optic trenches: Light + TRENCH® TERRATEST 7000 STREAM (Cable)	20
The "XL One" For highly compacted soil and base layers: Loading device with double impact force	22
The "XL One" and "Every Day One" ALL-INCLUSIVE-SET: Light + Medium-Heavy Falling Weight Deflectometer TERRATEST 7000 STREAM (Cable)	24
The "XL One" and "Every Day One" ALL-INCLUSIVE-SET: Light + Medium-Heavy Falling Weight Deflectometer TERRATEST 8000 WIRELESS (BLUETOOTH®)	26
Mobile Testing System CARRELLO	28
Technical details	30



**THE ONLY ONE
WITH TÜV CERTIFICATE!**



The "Every Day One" Testing normal compaction

TERRATEST 7000 STREAM (Cable)

2,990 €

HS Code 9024 8019

According to the german test certification TP BF-StB Part B 8.3
According to american society for testing materials (ASTM) E2835-11

Recognized compaction control in accordance with ZTV E 2009 and ZTV A 2012
2-year manufacturer's warranty
Free smartphone app for iOS and Android

Light Weight Deflectometer 10 kg for compaction tests up to $E_{v2} = 120 \text{ MN/m}^2$
Suitable for 90% of all requirements in earthworks, civil engineering and road construction

Measuring computer in weatherproof "ROBUSTA" electronics box with voice guidance

Full equipment: Wi-Fi, voice output, printer, GPS, power battery, USB-C, PC software

World's best-selling Light Weight Deflectometer – exported to over 100 countries

Buy directly from the manufacturer – no dealer or sales commission added!



**WEATHERPROOF. IMPACT-RESISTANT.
JUST ONE BUTTON.**
THE TERRATEST ELECTRONICS BOX.

Operate smart – even in tough conditions.

Operate the weatherproof and impact-resistant TERRATEST® electronics box directly on site using the external push button.

Your measuring computer and integrated printer remain perfectly protected against rain, dust and sand – for reliable testing results in any environment.

 **MADE IN GERMANY**

 **THE ONLY ONE WITH TÜV CERTIFICATE!**





voice guidance



The "Every Day One" Testing normal compaction

ALL-INCLUSIVE-SET TERRATEST 7000 STREAM (Cable)

3,490 €

According to the german test certification TP BF-StB Part B 8.3
According to american society for testing materials (ASTM) E2835-11

HS Code 9024 8019

Inclusive:

Light Weight Deflectometer TERRATEST 7000 STREAM (cable version)

"MILANO" transport box with wheels

"TRETMINNE" support stand for the drop weight and guide rod

5 paper rolls for the mini printer

World's best-selling Light Weight Deflectometer – exported to over 100 countries

Buy directly from the manufacturer – no dealer or sales commission added!

OFF-ROAD WHEELS FOR TRANSPORT BOX

125 €

Drive the transport box across the construction site directly to the test point!

HS Code 9024 9000

Tubeless solid rubber tires, 260 mm diameter

Compatible with all TERRATEST® transport boxes

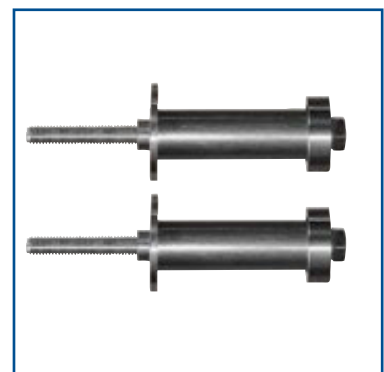



voice guidance

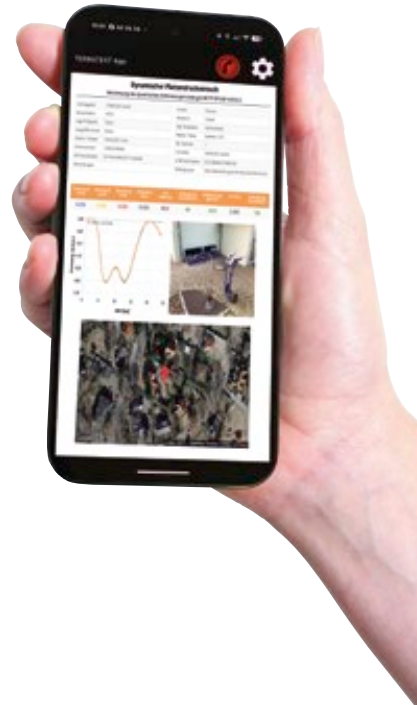

The "Every Day One" Testing normal compaction

TERRATEST 8000 APP

WITHOUT ROBUSTA MEASURING ELECTRONIC,
FOR SMARTPHONE OPERATION **ONLY** (iOS® + ANDROID®)



3,499 €

HS Code 9024 8019

You need just **two components** for testing: the **load plate** and the **drop weight**

Without the ROBUSTA measuring unit,
you control the device directly via your smartphone using the TERRATEST® App

Send digital PDF test reports by e-mail – no printouts required

World's best-selling Light Weight Deflectometer – exported to over 100 countries

Buy directly from the manufacturer – no dealer or sales commission added!



voice guidance



The "Every Day One" Testing normal compaction

ALL-INCLUSIVE-SET TERRATEST 8000 APP

WITHOUT ROBUSTA MEASURING ELECTRONIC,
FOR SMARTPHONE OPERATION **ONLY** (iOS® + ANDROID®)



3,990 €

HS Code 9024 8019

Inclusive:

Light Weight Deflectometer TERRATEST 8000 WIRELESS (BLUETOOTH®)
without ROBUSTA measuring electronics

"MILANO" transport box with wheels

"TRETMINNE" support stand for the drop weight and guide rod

World's best-selling Light Weight Deflectometer – exported to over 100 countries

Buy directly from the manufacturer – no dealer or sales commission added!

OFF-ROAD WHEELS FOR TRANSPORT BOX

Drive the transport box across the construction site directly to the test point!

125 €

HS Code 9024 9000

Tubeless solid rubber tires, 260 mm diameter

Compatible with all TERRATEST® transport boxes

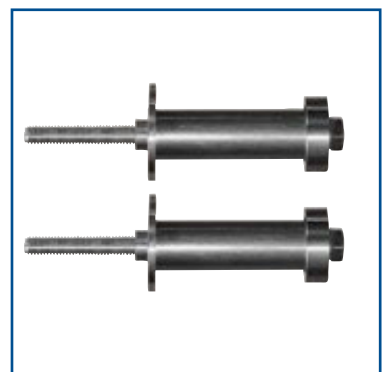

Our General Terms and Conditions apply. You can find them at light-weight-deflectometer.com/general-terms-conditions/
All prices are net, ex works, price list 03/2026. With the release of a new price list, all previous versions become invalid.



voice guidance

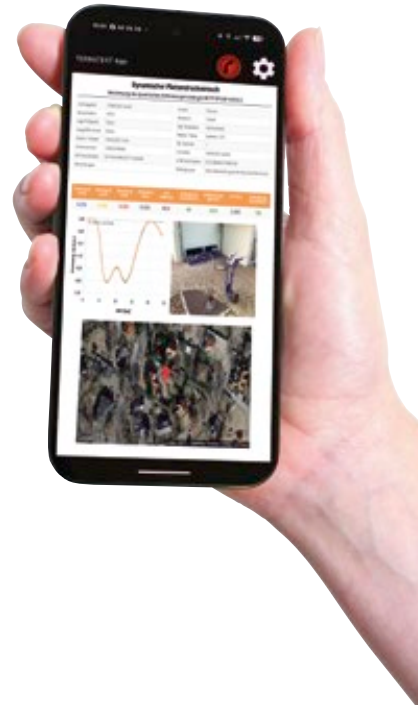

The "Every Day One" Testing normal compaction

TERRATEST 8000 WIRELESS

3,888 €

According to the german test certification TP BF-StB Part B 8.3
According to american society for testing materials (ASTM) E2835-11



Recognized compaction control in accordance with ZTV E 2009 and ZTV A 2012
2-year manufacturer's warranty
Free smartphone app for iOS and Android

Light Weight Deflectometer 10 kg for compaction tests up to $E_{v2} = 120 \text{ MN/m}^2$
Suitable for 90% of all requirements in earthworks, civil engineering and road construction

Measuring computer in weatherproof "ROBUSTA" electronics box with voice guidance

Full equipment: Wi-Fi, voice output, printer, GPS, power battery, USB-C, PC software

World's best-selling Light Weight Deflectometer – exported to over 100 countries

Buy directly from the manufacturer – no dealer or sales commission added!



**WEATHERPROOF. IMPACT-RESISTANT.
JUST ONE BUTTON.**

THE TERRATEST ELECTRONICS BOX.

Operate smart – even in tough conditions.

Operate the weatherproof and impact-resistant TERRATEST® electronics box directly on site using the external push button.

Your measuring computer and integrated printer remain perfectly protected against rain, dust and sand – for reliable testing results in any environment.



**THE ONLY ONE
WITH TÜV CERTIFICATE!**



Our General Terms and Conditions apply. You can find them at light-weight-deflectometer.com/general-terms-conditions/
All prices are net, ex works, price list 03/2026. With the release of a new price list, all previous versions become invalid.



voice guidance

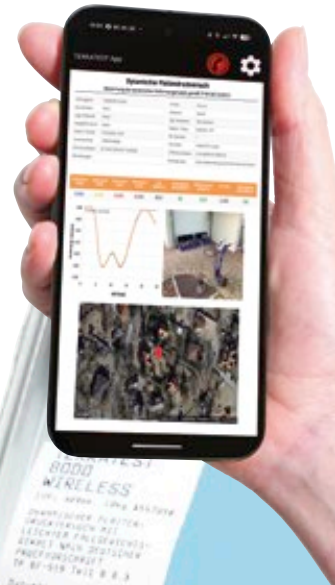

The "Every Day One" Testing normal compaction

ALL-INCLUSIVE-SET TERRATEST 8000 WIRELESS

According to the german test certification TP BF-StB Part B 8.3
According to american society for testing materials (ASTM) E2835-11



4,299 €

HS Code 9024 8019

Inclusive:

Light Weight Deflectometer TERRATEST 8000 WIRELESS (BLUETOOTH®)

"MILANO" transport box with wheels

"TRETMINNE" support stand for the drop weight and guide rod

5 paper rolls for the mini printer

World's best-selling Light Weight Deflectometer – exported to over 100 countries

Buy directly from the manufacturer – no dealer or sales commission added!

OFF-ROAD WHEELS FOR TRANSPORT BOX

Drive the transport box across the construction site directly to the test point!

125 €

HS Code 9024 9000

Tubeless solid rubber tires, 260 mm diameter

Compatible with all TERRATEST® transport boxes



Our General Terms and Conditions apply. You can find them at light-weight-deflectometer.com/general-terms-conditions/
All prices are net, ex works, price list 03/2026. With the release of a new price list, all previous versions become invalid.



voice guidance



The "Slim One" Testing small trenches

For narrow fiber-optic trenches

TERRATEST 7000 TRENCH[®] (Cable)

3,333 €

According to TERRATEST[®] factory standard, based on German testing specification TP BF-StB Part B 8.3 *HS Code 9024 8019*

5 kg drop weight with half impact force (3,535 N)

Load plate only 100 mm wide – ideal for use in narrow trenches during fiber-optic installation

"ROBUSTA" measuring electronics, Wi-Fi, voice assistant, printer, GPS, power battery, and PC software included

Additional kit (without measuring electronic)

TERRATEST 7000 TRENCH[®] (Cable)

2,499 €

According to TERRATEST[®] factory standard, based on German testing specification TP BF-StB Part B 8.3 *HS Code 9024 8019*

5 kg drop weight with half impact force (3,535 N)

Load plate only 100 mm wide – ideal for use in narrow trenches during fiber-optic installation

Without measuring electronic – calibration and firmware update performed on the customer's measuring electronics



voice guidance



100 mm



The "Slim One" Testing small trenches

ALL-INCLUSIVE-SET

TERRATEST 7000 TRENCH® (Cable)

3,666 €

According to TERRATEST® factory standard, based on German testing specification TP BF-StB Part B 8.3 *HS Code 9024 8019*

Inclusive:

Light Weight Deflectometer TERRATEST 7000 TRENCH® (cable version)

"VERONA" transport box with wheels

"TRETMINNE" support stand for the drop weight and guide rod

5 paper rolls for the mini printer

OFF-ROAD WHEELS FOR TRANSPORT BOX

125 €

Drive the transport box across the construction site directly to the test point!

HS Code 9024 9000

Tubeless solid rubber tires, 260 mm diameter

Compatible with all TERRATEST® transport boxes

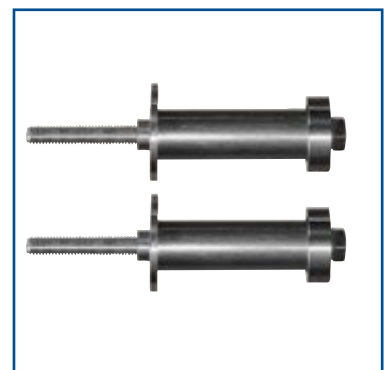



voice guidance

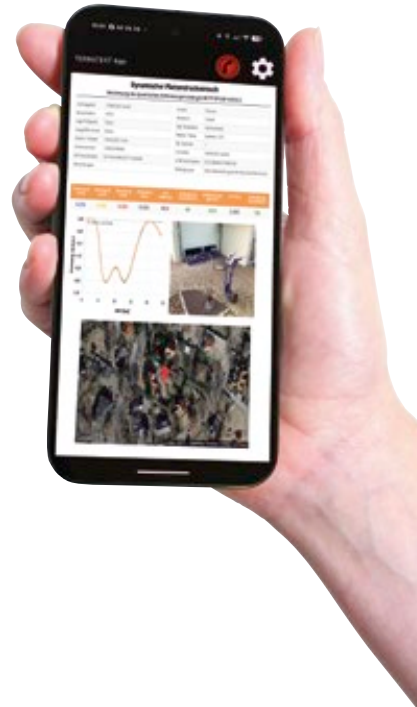

The "Slim One" Testing small trenches

ALL-INCLUSIVE-SET

Light Weight + TRENCH® Weight TERRATEST 7000 TRENCH® (Cable)

5,999 €

HS Code 9024 8019

According to the german test certification TP BF-StB Part B 8.3

According to american society for testing materials (ASTM) E2835-11

According to TERRATEST® factory standard, based on German testing specification TP BF-StB Part B 8.3

Inclusive:

Light Weight Deflectometer TERRATEST 7000 STREAM (cable version)

5 kg drop weight with half impact force (3,535 N)

Load plate only 100 mm wide – ideal for use in narrow trenches during fiber-optic installation

“BOLOGNA” transport box with wheels

“TRETMINNE” support stand for the drop weight and guide rod

5 paper rolls for the mini printer

OFF-ROAD WHEELS FOR TRANSPORT BOX

125 €

HS Code 9024 9000

Drive the transport box across the construction site directly to the test point!

Tubeless solid rubber tires, 260 mm diameter

Compatible with all TERRATEST® transport boxes

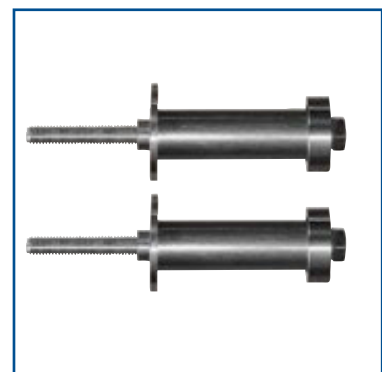



voice guidance



The "XL One"

Testing higher compaction

For highly compacted soil and base layers

Medium-sized Drop Weight
with double impact force

"MFG 2.0 Medium Heavy"

According to German testing standard TP Gestein-StB Part 8.2.1

1,480 €

HS Code 9024 8019

Medium-heavy falling weight (15 kg) for compaction tests
on highly compacted soil and base layers with $E_{v2} \geq 150 \text{ MN/m}^2$

Double impact force of 14,140 N thanks to reinforced spring assembly

World's best-selling Light Weight Deflectometer – exported to over 100 countries

Buy directly from the manufacturer – no dealer or sales commission added!



The "XL One" and "Every Day One" Testing higher compaction

ALL-INCLUSIVE-SET

Light Weight + Medium Weight TERRATEST 7000 STREAM (Cable)

4,999 €

HS Code 9024 8019

According to German testing standards TP BF-StB Part B 8.3 and TP Gestein-StB Part 8.2.1
According to american society for testing materials (ASTM) E2835-11

Including:

Light Weight Deflectometer TERRATEST 7000 STREAM (cable version)

Medium-heavy loading device with double impact force

Transport box "ROMA" with wheels for LWD and MFG

Support stand "TRETMINNE" for rod and falling weight

5 paper rolls for mini printer

World's best-selling Light Weight Deflectometer – exported to over 100 countries

Buy directly from the manufacturer – no dealer or sales commission added!

OFF-ROAD WHEELS FOR TRANSPORT BOX

125 €

HS Code 9024 9000

Drive the transport box across the construction site directly to the test point!

Tubeless solid rubber tires, 260 mm diameter

Compatible with all TERRATEST® transport boxes

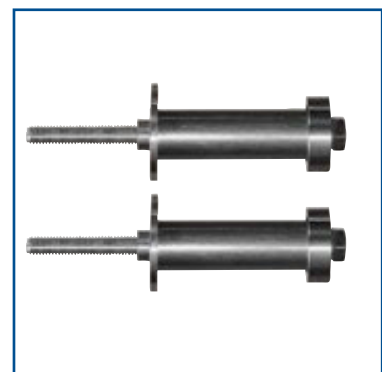



voice guidance

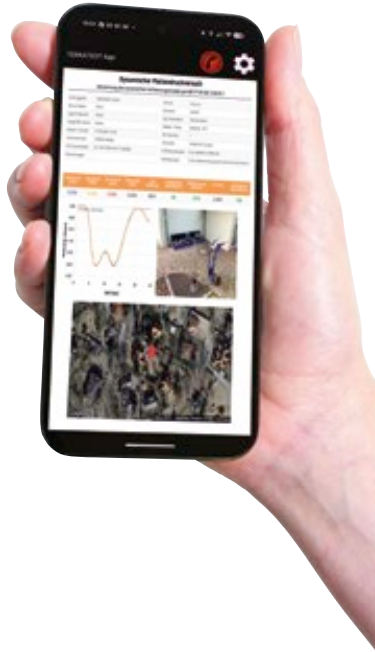

The "XL One" and "Every Day One" Testing higher compaction

ALL-INCLUSIVE-SET

Light Weight + Medium Weight TERRATEST 8000 WIRELESS

5,888 €

HS Code 9024 8019

According to German testing standards TP BF-StB Part B 8.3 and TP Gestein-StB Part 8.2.1
According to american society for testing materials (ASTM) E2835-11



Including:

Light Weight Deflectometer TERRATEST 8000 WIRELESS (BLUETOOTH®)

Medium-heavy loading device with double impact force

Transport box "ROMA" with wheels for LWD and MFG

Support stand "TRETMINNE" for rod and falling weight

5 paper rolls for mini printer

World's best-selling Light Weight Deflectometer – exported to over 100 countries

Buy directly from the manufacturer – no dealer or sales commission added!

OFF-ROAD WHEELS FOR TRANSPORT BOX

125 €

HS Code 9024 9000

Drive the transport box across the construction site directly to the test point!

Tubeless solid rubber tires, 260 mm diameter

Compatible with all TERRATEST® transport boxes

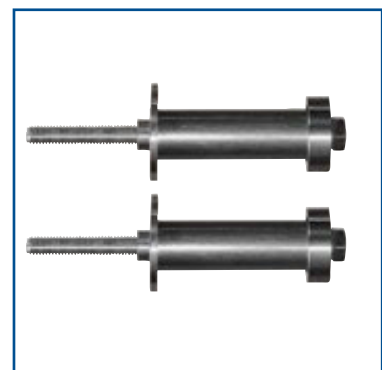



voice guidance

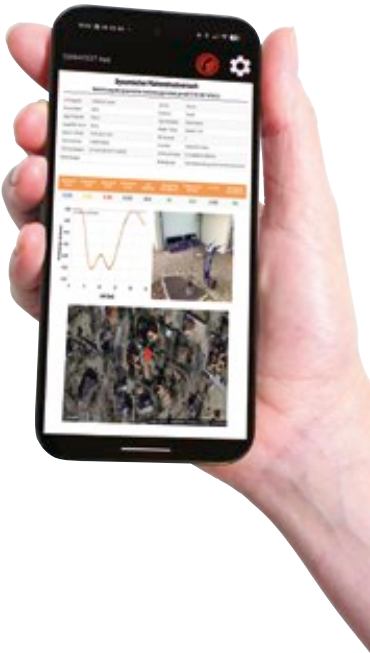

Mobile Testing System "CARRELLO"

880 €

Easily move the 35 kg device across the construction site

(price without Falling Weight Deflectometer)

Drive the transport box across the construction site directly to the test point!
Handcrafted vehicle construction – not a converted hardware-store trolley

HS Code 9024 9000

CNC-manufactured stainless-steel components

LWD remains permanently ready for testing on site

Comfortable operation at hip height

No need to lift or carry the LWD anymore

Foldable design for easy transport in a car

Tubeless, puncture-proof solid rubber tires





Technical details

Light Weight Deflectometer

according ASTM E2835-11

Electronic measuring computer "ROBUSTA"

Dimensions "ROBUSTA"-Box (L x W x H)

Weight "ROBUSTA"-Box, incl. measuring computer

Deflection range 0.1 to 2.0 mm \pm 0.02 mm

Measuring range E_{vd} < 225 MPa

Temperature range 0 to 40 °C

Extremely suitable for construction sites, protection class IP43 against dust and water, shock resistant, TÜV certified

Measuring cable using "Klinke"-Connection

Graphic display monochrom, illuminated

High performance 32bit-processor

GPS-system, precision < 10 m

USB-device for data storage

Thermal printer

Bluetooth® System, Bluetooth® Low Energy 4.1, range 10 m

WiFi for web application, 2,4 GHz, IEEE 802.11 b/g/n-compliant

Voice-Command, spoken menu navigation, 10 languages available

Capacity of internal memory

power battery, 6,9 Volt, rechargeable, Capacity: 2000 Tests or 600 printouts, lifetime 5 years/20°C

Electronic measuring computer Load plate Bluetooth (only 8000 WIRELESS)

Deflection range 0.1 to 2.0 mm \pm 0.02 mm

Measuring range < 225 MPa

Temperature range 0 bis 40 °C

Extremely suitable for construction sites, protection class IP43 against dust and water, shock resistant, TÜV certified

High performance 32bit-processor

Bluetooth® System, Bluetooth® Low Energy 4.1, range 10 m

Lithium-Ionen-battery, 9 V, rechargeable, Capacity 5000 Tests, Lifetime 6-8 years/20°C

LWD load mechanism, 10 kg falling weight

Steel ST52, chemically nick plated

Total weight 15 kg \pm 150 g

Mass of falling weights 10 kg \pm 100 g

maximum impactforce 7,07 kN \pm 70 N

Time of impact 17.0 ms \pm 1.5 ms

Spring element 17 disk springs

Load plate

Steel ST52, chemically nick plated

Diameter 300 mm \pm 0.5 mm

Plate thickness 20 mm \pm 0.2 mm

Plate weight 15 kg \pm 250 g

Acceleration meter

2 grips, Aluminium

Load head with Bluetooth® System



TERRATEST 7000 STREAM (CABLE)



TERRATEST 8000 APP



TERRATEST 8000 WIRELESS (BLUETOOTH®)

230 x 220 x 170 mm

4 kg

-
-
-
-
-

40 x 72 mm

-
-
-
-

2000

-

230 x 220 x 170 mm

4 kg

-
-
-
-

40 x 72 mm

-
-
-
-

2000

-

Smartphone
Smartphone

Smartphone
Smartphone
Smartphone

-
-
-
-
-
-
-

-
-
-
-
-
-
-

-
-
-
-
-
-

-
-
-
-
-
-

-
-
-
-
-
-

-
-
-
-
-
-

-
-
-
-
-
-

-
-
-
-
-
-

-

-



Frank G. Schulz
CEO

Mobil +49 178 54 54 390

TERRATEST GmbH
Oranienburger Chaussee 20 · 16775 Löwenberger Land · GERMANY
Tel: +49 33 01 700 700 · www.terratest.de · info@terratest.de



TERRATEST GmbH
Oranienburger Chaussee 20
16775 Löwenberger Land · GERMANY

Tel: +49 33 01 700 700
www.terratest.de
info@terratest.de