

► **KaDius**  
Fan coils

# KaDius

Versatile air conditioning for new and existing buildings  
with exacting design and aesthetic standards

► **Technical catalogue**

**KAMPMANN**



# Contents

<b>01 ▶ Product information</b>	<b>6</b>
▶ KaDius – innovative, versatile air conditioning that satisfies high design expectations in new and existing buildings.	7
▶ Product data	8
▶ Selection guide	9
▶ KaDius at a glance	10
<b>02 ▶ Technical data</b>	<b>14</b>
▶ Advice on measuring conditions	15
▶ KaDius, Housing partially cased, Model size 1	16
▶ KaDius, Housing fully case, Model size 1	18
<b>03 ▶ Design information</b>	<b>20</b>
▶ Information on planning and design	21
▶ Unit arrangements in the room	22
▶ Condensate drain	23
▶ On-site design elements	23
▶ Condensate pump	24
▶ Automatic hydraulic balancing	24
▶ Versions and adaptations	25
▶ Other design ideas	26
<b>04 ▶ Accessories</b>	<b>28</b>

A photograph of a modern interior space, likely a museum or gallery. The ceiling is a prominent feature, featuring a curved, ribbed design with a series of parallel, rounded slats. Several circular lighting fixtures are suspended from the ceiling, some of which are illuminated, casting a warm glow. The space is bright, with large windows on the left side. In the foreground, there is a large, curved structure with a blue and purple illuminated panel. The overall atmosphere is clean, modern, and well-lit.

KaDius: versatile air conditioning for new and existing buildings



When you choose the KaDius, you are opting for a fan coil for heating and cooling with exceptionally high-quality design and functionality.

# 01 ▶ Product information

---



## KaDius – innovative, versatile air conditioning that satisfies high design expectations in new and existing buildings.

KaDius units are ceiling units with design appeal for efficient air conditioning of interiors in new and existing buildings. They are ideal for heating and cooling, especially in rooms with open ceilings and sophisticated design requirements.

Due to their minimalist, round design, KaDius units are the ideal complement to sophisticated interior designs with open ceilings. Due to the many different design options, the units can be easily integrated into existing interior designs according to requirements. Casing components are available in a wide range of colours, units can be combined with ring lights and decorative films can be applied to the units so they can be easily adapted to design requirements. The required accessories, such as valves, are inside the units, and therefore do not affect the visual appearance of the units.

The option of installing the units very close to the ceiling combined with the closed underside rounds off the innovative design concept. Horizontal 360° discharge ensures an even movement of air in the room.

### Variable comfort solution

Apart from their versatility and aesthetic appearance, the units provide an exceptional range of outputs coupled with low noise levels. Draughts are prevented by an optimised discharge behaviour, which ensures high levels of comfort when the space is occupied.

### Operating principle

Wedge-shaped baffles in the air outlet of the housing direct the air in high-impulse streams to avoid excessive induction and extend throw distances.

The individual air streams fan out and combine to create an even air movement. Air is drawn in from the dead zones in the area of the wedge-shaped baffles without interrupting the discharging air streams. The units can therefore be installed close to the ceiling and project downwards by up to only 100 mm without adversely affecting the output.

### Simple maintenance and hygiene

Maintaining is very simple as the lower segment of the unit can be easily lowered to allow access to maintenance-relevant components.

Easy and straightforward cleaning and maintenance guarantees hygienically perfect air conditioning even after several years.



Heating mode

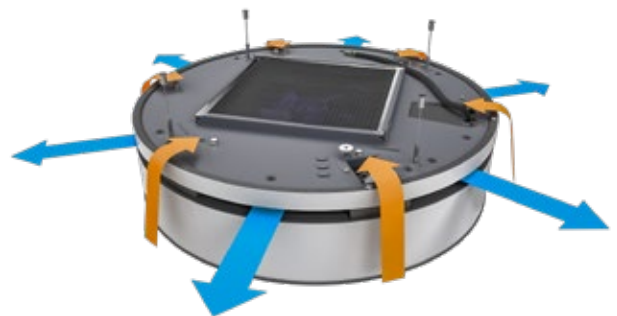

Cooling mode

# Product data



## Product benefits

- ▶ Internal room design concept with versatile adaptation options
- ▶ Its utility model-protected design enables it to be installed with minimal clearance from the ceiling
- ▶ All components including accessories are accommodated within the unit and are invisible from the outside
- ▶ Thermally and acoustically insulated housing made of EPP (expanded polypropylene)
- ▶ Comfortable heating and cooling with 360° air outlet
- ▶ Unique maintenance concept with easy access to all components
- ▶ Fully automatic KaControl or connection to an existing, external building automation system



## Features

- ▶ Round design ceiling unit for use in modern interior design schemes
- ▶ Two casing options
- ▶ Continuously variable, energy-saving EC fan
- ▶ Quiet condensate pump with high delivery capacity integrated
- ▶ With factory-fitted and tested valve kit including stainless steel corrugated pipes is available
- ▶ Low installation weight thanks to EPP basic body
- ▶ Various valve kits available
- ▶ Easy installation

<b>Installation</b>	▶ Ceiling-mounted
<b>Primary air supply</b>	▶ ---
<b>Heating</b>	▶ LPHW
<b>Cooling</b>	▶ CHW
<b>KaControl</b>	▶ Optional

## Performance data

**Cooling output [W]<sup>1)</sup>** > 2142 – 5691

**Heat output [W]<sup>2)</sup>** > 4734 – 12970

**Air flow [m<sup>3</sup>/h]** > 282 – 896

**Sound pressure level [dB(A)]<sup>3)</sup>** > 25 – 55

<sup>1)</sup> at CHW 7/12 °C, t<sub>1</sub> = 27 °C, 48% relative humidity

<sup>2)</sup> at LPHW 75/65 °C, t<sub>1</sub> = 20 °C

<sup>3)</sup> The sound pressure levels were calculated with an assumed room insulation of 8 dB(A).

### Operating limits

- ▶ Max. operating pressure: 10 bar
- ▶ Max. entering water temperature: 75 °C
- ▶ Min. entering water temperature: 6 °C
- ▶ Max. air inlet temp.: 30 °C
- ▶ Max. glycol volume: 50 %

## Applications

Buildings of all kinds, which require whisper-quiet cooling or heating from a visually discreet design.



## Selection guide

Model size	Diameter (A) [mm]	Dimensions		Air flow [m <sup>3</sup> /h]	Cooling output <sup>1)</sup> [W]	Heat output <sup>2)</sup> [W]	Sound pressure level [dB(A)]
		Height (C) [mm]	Height (B) [mm]				
1	852	208	224	282 – 896	2142 – 5691	4734 – 12970	25 – 55

<sup>1)</sup> at CHW 7/12 °C,  $t_{11} = 27$  °C, 48% relative humidity

<sup>2)</sup> at LPHW 75/65 °C,  $t_{11} = 20$  °C

### Technical drawing (Dimensions in mm)

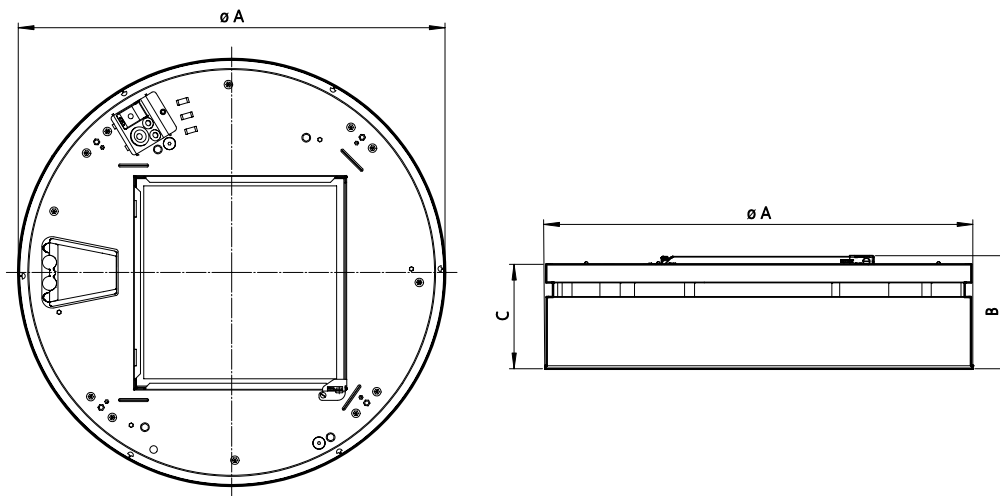

## KaDius at a glance





### ① Casing

- ▶ Unobtrusive no frills design, manufactured from 1 mm powder-coated sheet steel
- ▶ The basic colour of the KaDius casing is traffic white (RAL 9016)
- ▶ A wide range of colours is available for no or only a small additional charge
- ▶ Individual colours can be selected as required
- ▶ A partially enclosed version of the unit with cover trim, but without casing rings, is available



### ② Expanded polypropylene (EPP) housing

- ▶ The starting point for the basic unit is an innovative utility model-protected EPP basic structure
- ▶ EPP is characterised by its high rigidity, low weight and outstanding insulation properties and recyclability
- ▶ Optimum air routing, as complex shapes are possible
- ▶ Organic internal structures for straightforward cleaning

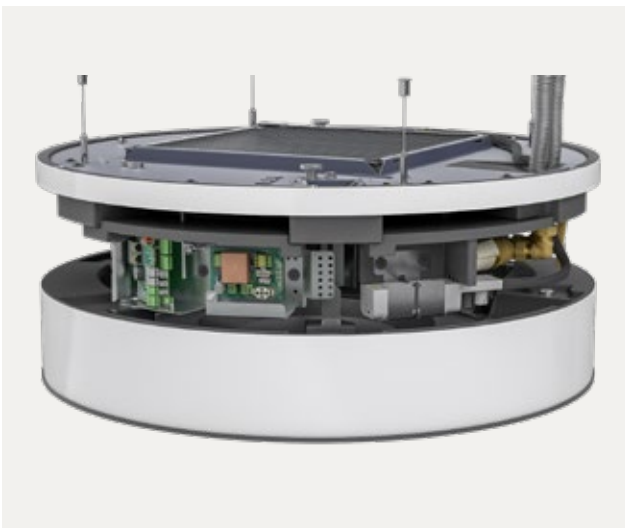

### ③ Innovative maintenance concept

- ▶ Lower section of the unit easily drops down
- ▶ To do so, simply loosen two knurled screws and pull down the lower part (held in place by magnets) until it hangs on the guide rail
- ▶ All components are easily accessible for cleaning

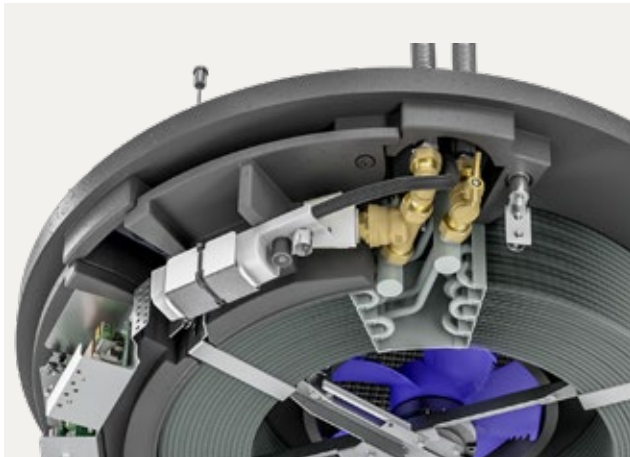

#### ④ Condensate tray with condensate pump

- ▶ An extremely quiet and powerful condensate pump with capacitive resistance sensor is pre-installed
- ▶ Lower unit segment serves as a condensate tray
- ▶ Gradient on all sides towards the intake area of the pump for fast comprehensive condensate drainage from the air-guiding section
- ▶ Well-thought-out concept for straightforward maintenance and cleaning



#### ⑤ Axial fan with safety guard

- ▶ Infinitely-variable EC axial fan
- ▶ Quiet and highly efficient due to aerodynamic vane geometry
- ▶ Active temperature management prevents overheating of the fan.
- ▶ IP class 54

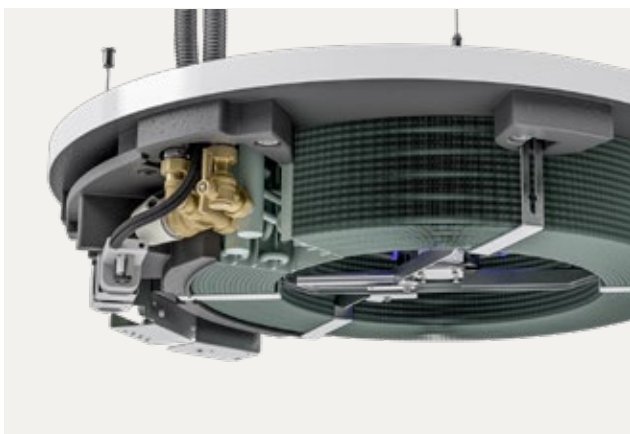

#### ⑥ Heat exchanger with pre-installed valve kit

- ▶ High-efficiency heat exchanger with copper pipes and aluminium fins.
- ▶ Suitable for low temperature heating systems
- ▶ Internal factory mounted valve kit
- ▶ Optional thermostatic valve or non differential pressure-dependent valve for automatic hydraulic balancing
- ▶ Shut-off valve in the unit return line
- ▶ Stainless steel corrugated pipes (18 x 1 mm) for connection to the supply lines



### 7 Connection and operational safety

- ▶ Unit design and component selection optimised for ease of assembly and operation
- ▶ Lower overall weight by using EPP
- ▶ Connection and pre-installed corrugated pipes outside the unit
- ▶ External repair switch

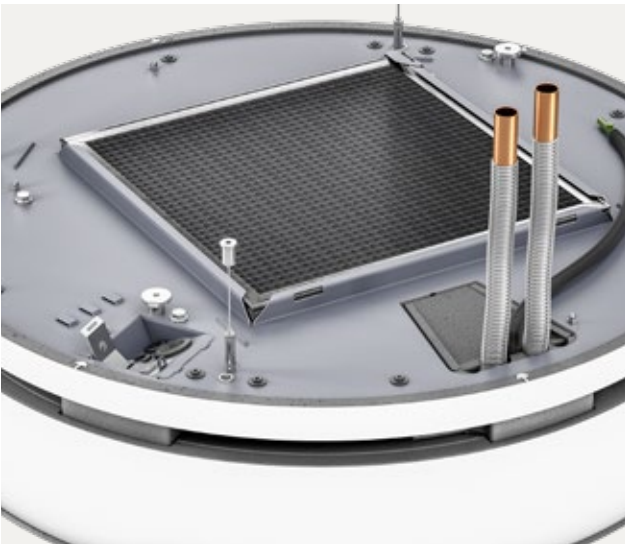

### 8 ISO Coarse filter

- ▶ Filters the dust from the room air
- ▶ Guards against unintentional contact with internal components and ingress of dirt
- ▶ Filter can be easily removed by turning a lock

## 02 ▶ Technical data

---

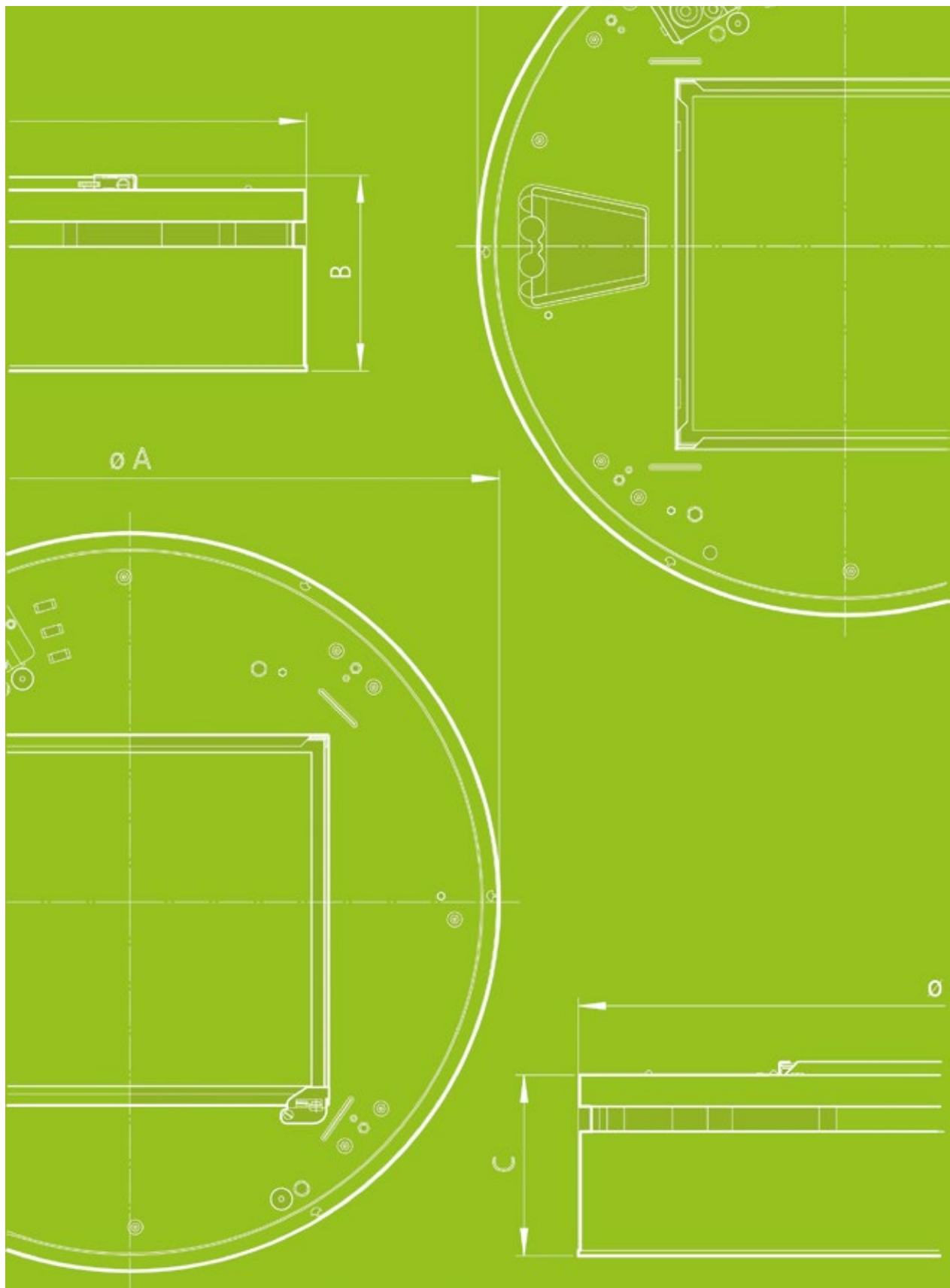

## Advice on measuring conditions

The cooling and heating outputs have been calculated in accordance with DIN EN 1397:2015 "Water-air fan coils, test methods for determining the output".

The specific requirements for cooling and heating mode are taken into account in DIN EN 1397. They are also based on the Eurovent certification.

### Normative reference

The standard refers to:

- ▶ EN 16583; Determining the sound power levels of noise sources
- ▶ EN 45001; General criteria for the operation of test laboratories
- ▶ ISO 5801; Industrial fans; Performance testing using standardised airways
- ▶ ISO 5221; Air distribution and air diffusion; Rules for methods of measuring air flow rate in an air handling duct

The air intake temperature of the fan coil is selected as the reference/air temperature, and should not be confused with the room temperature.

In practice, fan coils are positioned above the suspended and open ceilings, or as sill units along the façade. Due to the temperature stratification that occurs, the air intake temperature differs from the room air temperature (measured at a height of 1.5 m).

### Acoustics

Fan coils are very often used in acoustically sensitive spaces. The noise levels of the units have therefore been optimised.

The acoustic data was recorded according to the provisions of DIN EN 16583 by DIN EN ISO 3744 and DIN EN ISO 3741 in the Kampmann GmbH laboratories.

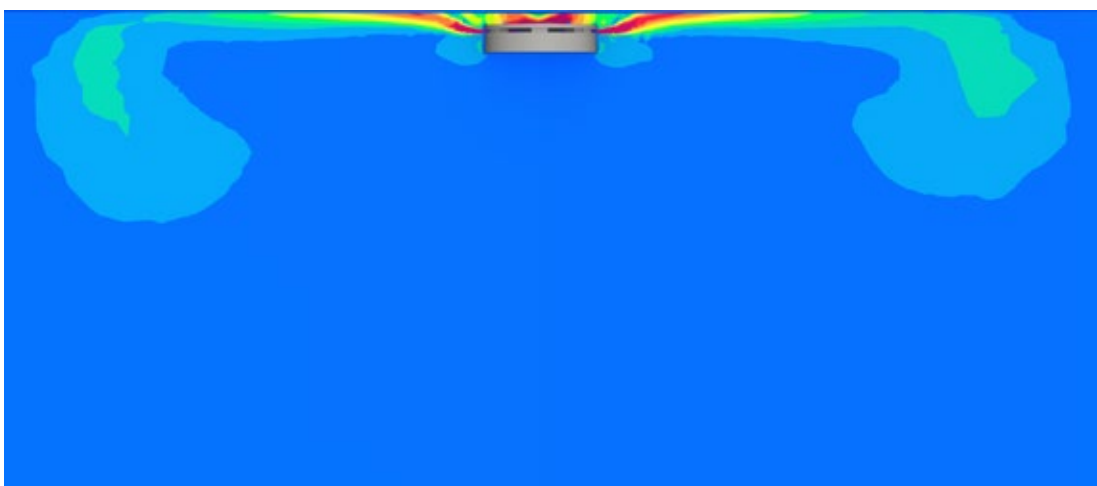

CFD simulation

# KaDius

## Housing partially cased

### Model size 1

Technical drawing (Dimensions in mm)

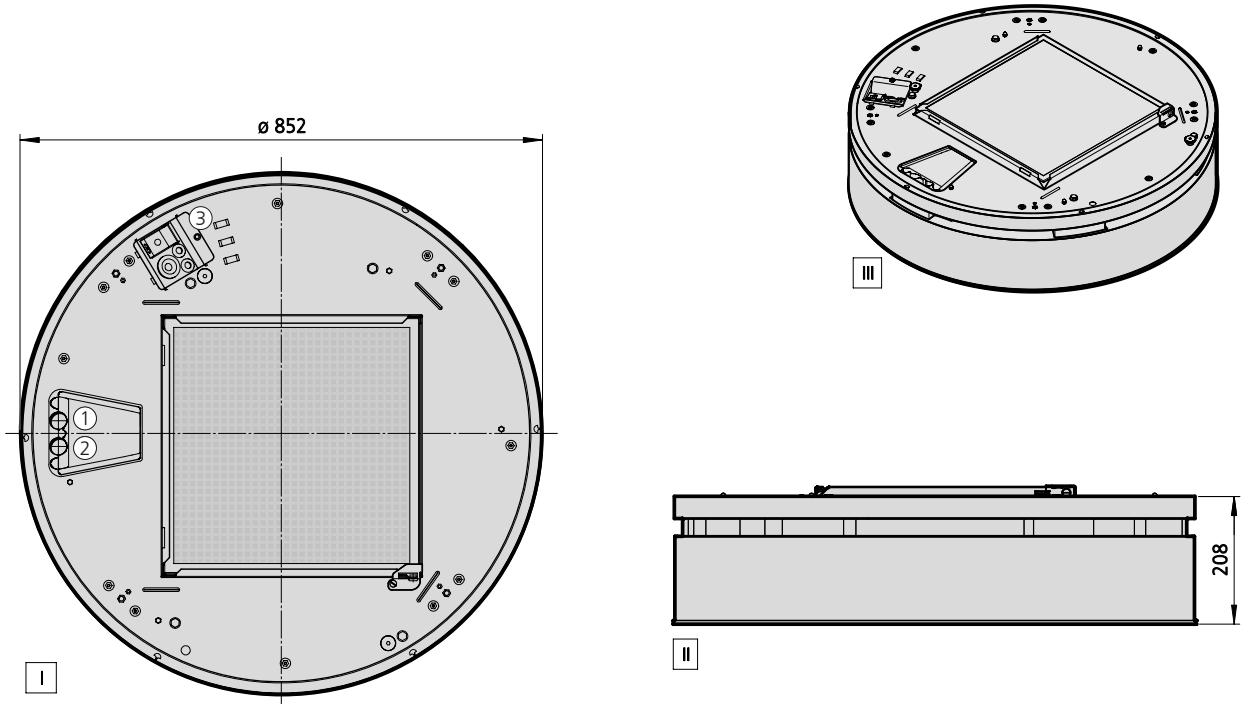

#### View

- I top view
- II Front view
- III isometric view

#### Further information

- ① Flow
- ② Return
- ③ Repair switch

#### Specifications

Article no.	Valve version	Housing	Water connections	Water content [l]	Connection	Weight [kg]
360001200011**	2-way valve, not pre-settable	partially cased	Top	1.8	3/4"	21
360001200012**	Pressure-independent valve kit	partially cased	Top	1.8	3/4"	22

**Performance data**

System	Control voltage	Air flow	Cooling output, total <sup>1)</sup>	Cooling output, sensible	Outlet air temperature	Mass Flow cooling	Pressure loss cooling	Condensation	Heat output <sup>2)</sup>	Outlet air temperature	Mass Flow heating	Pressure loss heating	Power consumption	Current consumption	SFP value	Sound pressure level <sup>3)</sup>	Sound power level
	[V]	[m³/h]	[W]	[W]	[°C]	[l/h]	[kPa]	[l/h]	[W]	[°C]	[l/h]	[kPa]	[W]	[mA]	[Ws/m³]	[dB(A)]	[dB(A)]
2-pipe	10	896	5691	4010	13.1	976	34.2	2.7	12970	63.6	1143	34.8	55	458	220	55	63
	8	732	4822	3343	12.8	826	25.4	2.4	10960	65.1	966	25.7	32	292	158	50	58
	6	578	3957	2702	12.5	678	17.9	2.0	8965	66.7	790	17.9	19	187	117	43	51
	4	400	2908	1953	11.9	499	10.3	1.5	6501	68.9	573	10.1	10	111	92	35	43
	2	282	2142	1422	11.3	367	6.0	1.1	4734	70.6	417	5.7	7	78	87	25	33

Use our calculation tools on our website to easily calculate heat outputs and other technical data with just a few clicks!

► <https://www.kampmanngroup.com/hvac/products/fan-coils/kadius#Calculate-performance-data>

<sup>1)</sup> at CHW 7/12 °C,  $t_{r1} = 27$  °C, 48% relative humidity

<sup>2)</sup> at LPHW 75/65 °C,  $t_{r1} = 20$  °C

<sup>3)</sup> The sound pressure levels were calculated with an assumed room insulation of 8 dB(A). This corresponds to a distance of 2 m, a room volume of 100 m³ and a reverberation time of 0.5 s (in accordance with VDI 2081)

# KaDius

## Housing fully cased

### Model size 1

Technical drawing (Dimensions in mm)

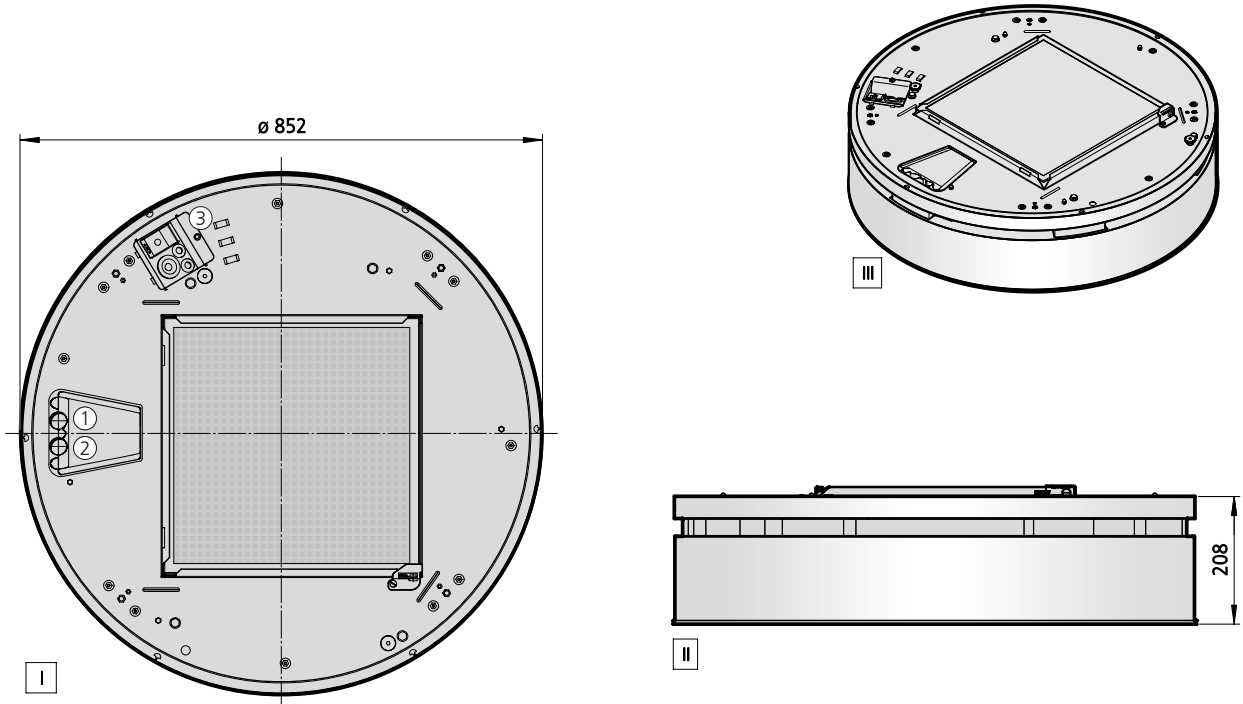

#### View

- I top view
- II Front view
- III isometric view

#### Further information

- ① Flow
- ② Return
- ③ Repair switch

#### Specifications

Article no.	Valve version	Housing	Water connections	Water content [l]	Connection	Weight [kg]
360001200021**	2-way valve, not pre-settable	fully cased	Top	1.8	3/4"	26
360001200022**	Pressure-independent valve kit	fully cased	Top	1.8	3/4"	26

**Performance data**

System	Control voltage	Air flow	Cooling output, total <sup>1)</sup>	Cooling output, sensible	Outlet air temperature	Mass Flow cooling	Pressure loss cooling	Condensation	Heat output <sup>2)</sup>	Outlet air temperature	Mass Flow heating	Pressure loss heating	Power consumption	Current consumption	SFP value	Sound pressure level <sup>3)</sup>	Sound power level
	[V]	[m³/h]	[W]	[W]	[°C]	[l/h]	[kPa]	[l/h]	[W]	[°C]	[l/h]	[kPa]	[W]	[mA]	[Ws/m³]	[dB(A)]	[dB(A)]
2-pipe	10	896	5691	4010	13.1	976	34.2	2.7	12970	63.6	1143	34.8	55	458	220	55	63
	8	732	4822	3343	12.8	826	25.4	2.4	10960	65.1	966	25.7	32	292	158	50	58
	6	578	3957	2702	12.5	678	17.9	2.0	8965	66.7	790	17.9	19	187	117	43	51
	4	400	2908	1953	11.9	499	10.3	1.5	6501	68.9	573	10.1	10	111	92	35	43
	2	282	2142	1422	11.3	367	6.0	1.1	4734	70.6	417	5.7	7	78	87	25	33

Use our calculation tools on our website to easily calculate heat outputs and other technical data with just a few clicks!

► <https://www.kampmanngroup.com/hvac/products/fan-coils/kadius#Calculate-performance-data>

<sup>1)</sup> at CHW 7/12 °C,  $t_{r1} = 27$  °C, 48% relative humidity

<sup>2)</sup> at LPHW 75/65 °C,  $t_{r1} = 20$  °C

<sup>3)</sup> The sound pressure levels were calculated with an assumed room insulation of 8 dB(A). This corresponds to a distance of 2 m, a room volume of 100 m³ and a reverberation time of 0.5 s (in accordance with VDI 2081)

# 03 ▶ Design information

---

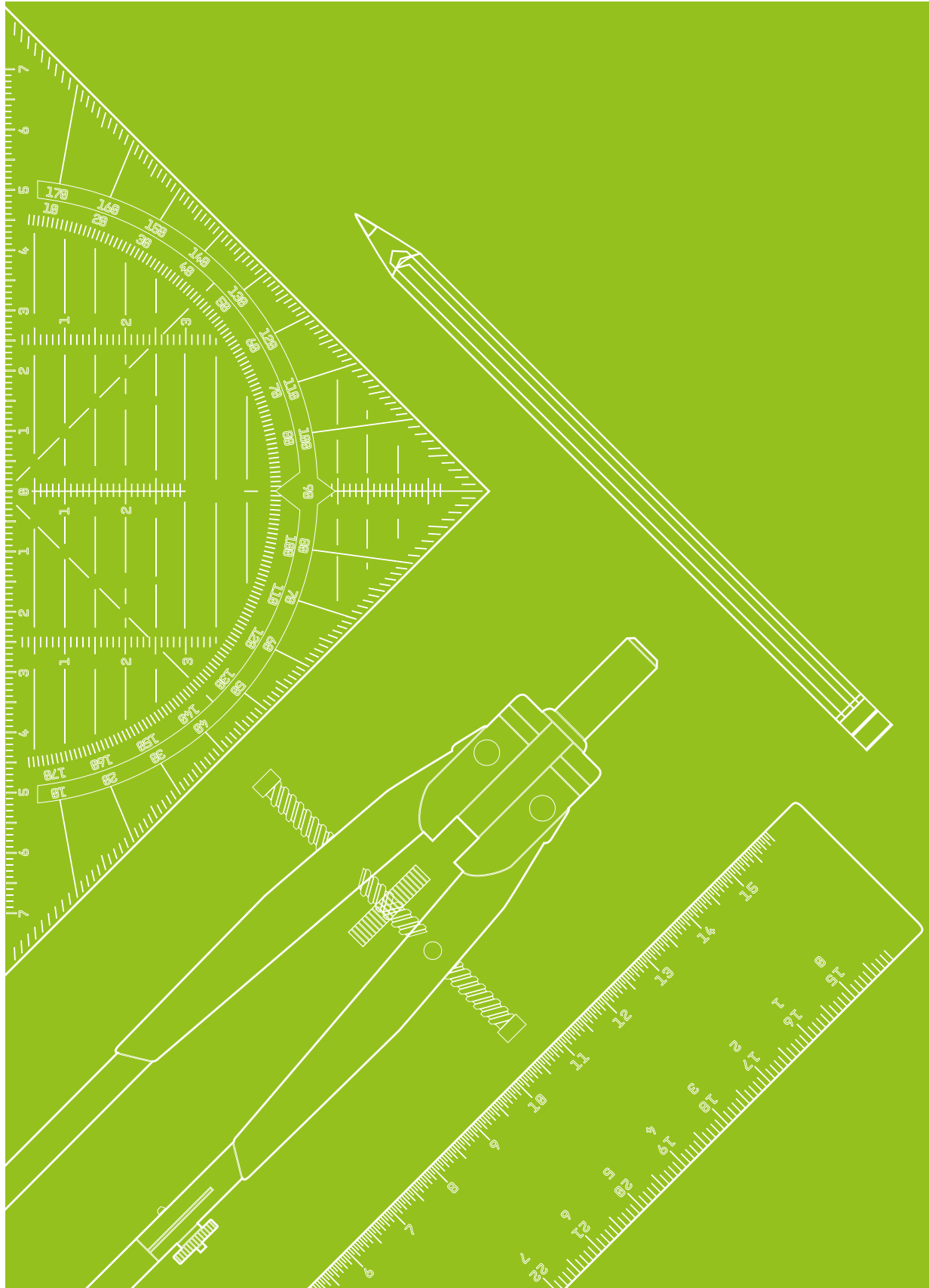

## Information on planning and design

A number of factors need to be taken into consideration during the planning and design phase.

### Unit design

KaDius units are available in one size. The required number of units depends not just on the heating and cooling load calculated, other factors, including the building and acoustic conditions and specific characteristics of the unit, need to be taken into consideration.

The required number and design stage are calculated based on the:

- ▶ Calculated heating or cooling output
- ▶ Maximum mounting height
- ▶ Sound level to be adhered to
- ▶ Structural conditions, such as occupied zones, installation points, fixtures and furnishings

### Mounting

The mounting position of the units essentially depends on the architecture of the building and the design requirements. These units cannot be installed in suspended ceilings. The minimum mounting distance from the top of the unit to the ceiling is 100 mm. The units are designed to be suspended from threaded rods or cables. The mounting method depends on the type of ceiling. During construction, the outer packaging of the units protects them and prevents the ingress of dust and dirt particles.

### Cooling mode

The existing cooling load is calculated in line with VDI 2078 (VDI regulations governing cooling loads).

When planning and installing the cold water network, bear in mind that the units can always be used for wet cooling, thanks to a pre-fitted condensate pump.

This requires a connection to an on-site drain and appropriate insulation of the pipes against condensation. Wet cooling makes it possible to meet high cooling requirements.

### Air discharge behaviour

KaDius units blow air horizontally into the room in all directions (360°). Providing the devices are positioned correctly, there are no draughts in the occupied zone, which increases the feeling of comfort. To avoid draughts at higher fan speeds, the distance of the unit from the wall must be no less than 1.5 m.

### Maximum operating pressure

The maximum operating pressure of the KaDius with pre-fitted valves and corrugated pipes is 10 bar.

A pressure resistance of up to 25 bar is guaranteed for units without valves and corrugated pipes. In this case, the units are connected on site from the heat exchanger.

### Avoid:

- ▶ Restricted air circulation due to lamps, furniture or shelves
- ▶ Obstacles to air distribution and air intake
- ▶ Electronic appliances below the KaDius



Example of unit suspended with wire cables

## Unit arrangements in the room

Units are positioned taking their discharge behaviour and the architecture and environment (e.g. ceiling lights) into consideration. The suspension height and throw distances are also decisive for the positioning of the units in the room. If there are desks in the middle of a room, for example, the KaDius units should be positioned above them. This prevents people in the occupied zone from being affected by draughts.

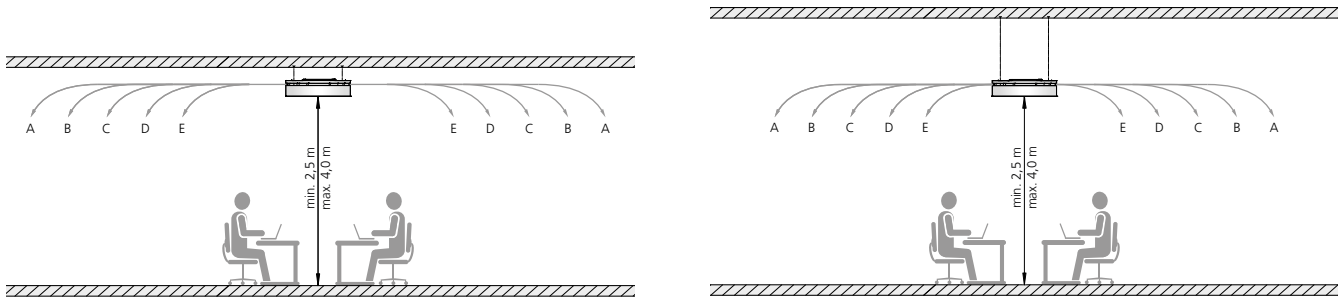

Example of suspension height and throw distances

Points	Air volume flow [%]	Throw [m]
A	100	3.25
B	80	2.75
C	60	2.25
D	40	1.75
E	20	1.25

Points	Air volume flow [%]	Throw [m]
A	100	2.75
B	80	2.25
C	60	1.75
D	40	1.25
E	20	0.75

The aim is to avoid draughts in the room and thus ensure thermal comfort. To achieve this, it is essential to maintain clearance from walls and between two units.

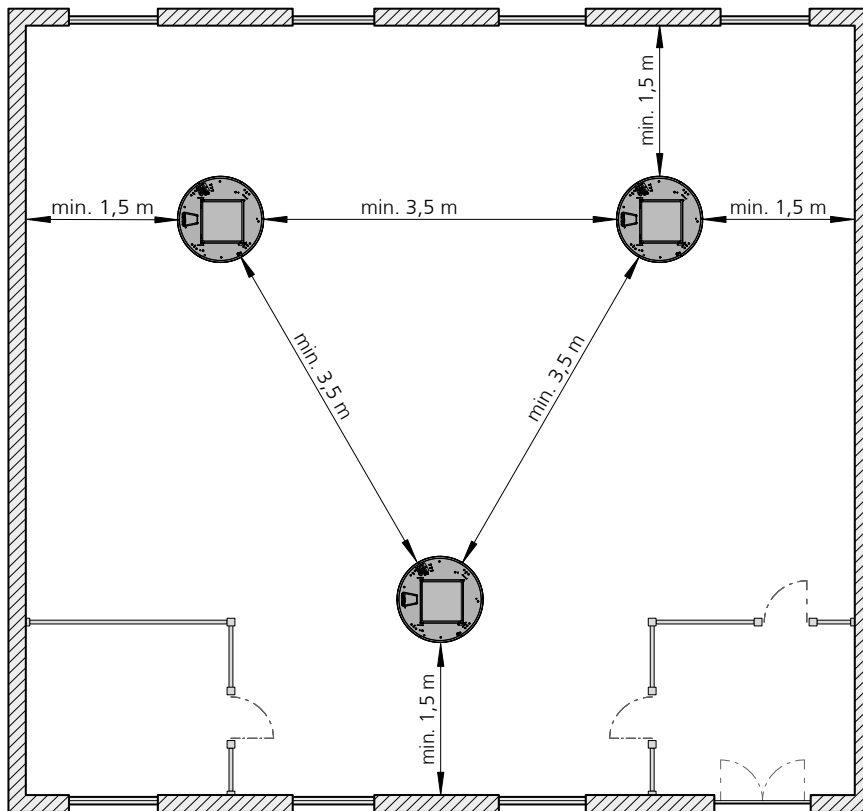

Example of unit layout in the room

## Condensate drain

The units are always designed for wet cooling and have an integrated condensate pump with capacitive sensor to monitor the condensate level.

The condensate discharged from the condensate pump hose must be drained from the unit at a gradient of 1%.

The condensate must be collected in a pool pump on site if it has to be removed to a higher level than the integrated pump allows.

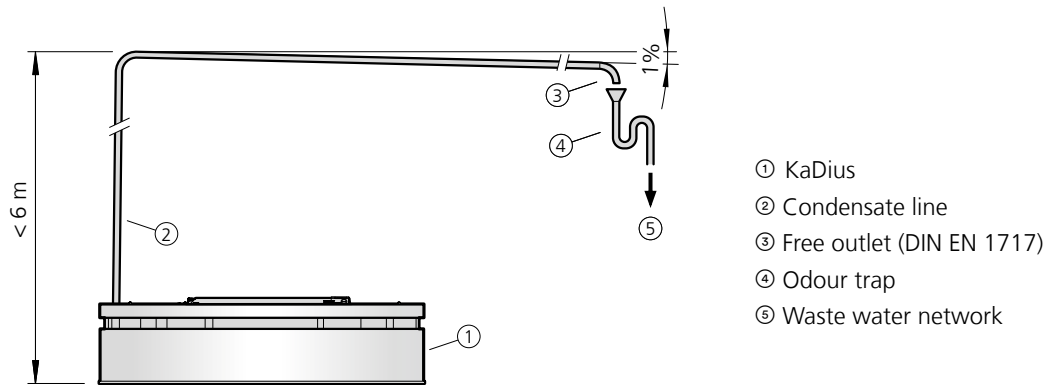

## On-site design elements

KaDius units can be hung on site with design elements, such as ring lights. However, these elements must not be attached to the KaDius. Ring lights must have a minimum internal diameter of 950 mm and a maximum material thickness of 40 mm to ensure proper operation and maintenance of the unit. Larger dimensions require the design elements to be removed or lowered to ensure proper (barrier-free) maintenance of the KaDius.

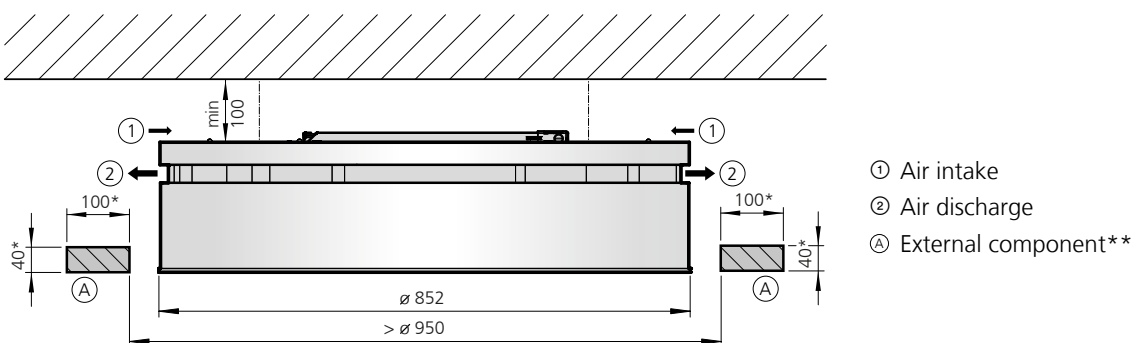

\*With larger dimensions, ensure that the external component can be removed or lowered to allow maintenance of the KaDius to be correctly carried out.

\*\*External component (example: light, acoustic module, ...)

## Condensate pump

The self-priming condensate pump with capacitive resistance sensor to monitor the liquid level is factory-fitted in the unit. The condensate hose is routed out of the top of the unit and prepared for connection on site.

The condensate pump is installed directly in the pump sump and so can be accessed with ease when maintaining the KaDius. To carry out maintenance, it can be removed quickly and easily from the unit by loosening two screws.

Maximum delivery height	20 m
Flow rate	42 l/h
Supply voltage	230 V/50 Hz
Power consumption	8 W
Condensate discharge line	6.25 mm inner diameter
Conformity	UK 778

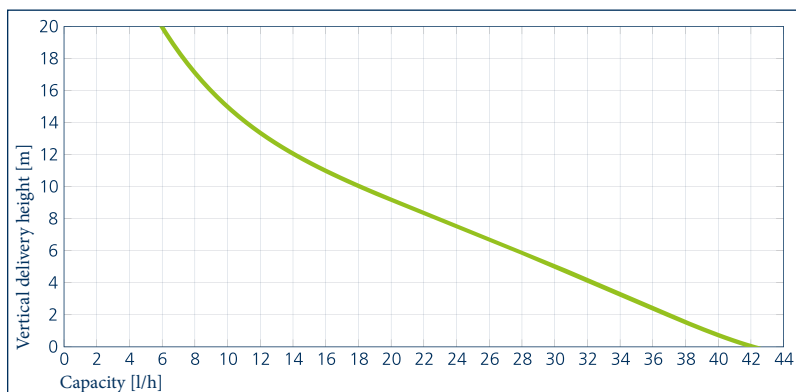

## Automatic hydraulic balancing



Differential pressure-independent valves maximise the volume flow of the heating/cooling medium with reference to the set value. Regardless of the pipe network or available pressure, each consumer receives only the volume envisaged for it. The system is considered hydraulically balanced as soon as the supply to each consumer is sufficient.

## Acoustics



Noise-optimised, quiet EC fans are fitted in the KaDius. The respective sound pressure and sound power levels are listed in tables provided in the technical data. The sound pressure levels were calculated according to VDI 2081 with an assumed room attenuation of 8 dB(A). This corresponds to a distance of 2 m, a room volume of 100 m<sup>3</sup> and a reverberation time of 0.5 s. However, because the sound pressure level is not only influenced by the KaDius itself, but is also highly dependent on the acoustic properties of the room, the value may deviate in practice. We would recommend taking the respective permitted sound pressure level in the room into account when designing KaDius units.

## Versions and adaptations

Not every building project has the same requirements. KaDius units offer a wealth of options for adapting to interior design schemes.

### Casing

The units are available partially encased or fully encased.



KaDius, partially encased



KaDius, fully encased

### Colour selection

The colour of the casing can be customised. We have a wide range of standard colours to choose from.

- ▶ raffic-white satin gloss (RAL 9016 SG)
- ▶ satin gloss white aluminium (RAL 9006 SG)
- ▶ iron-glimmer grey matt-satin matt (DB 703 MA-SM)
- ▶ matt satin deep black (RAL 9005 MA-SM)
- ▶ moss green matt (RAL 6005 MA)
- ▶ reddish brown metallic fine structure
- ▶ gold metallic fine structure

All other colours can be provided for an additional charge.

**Attention:** The colors shown may vary from the actual colors depending on your screen.

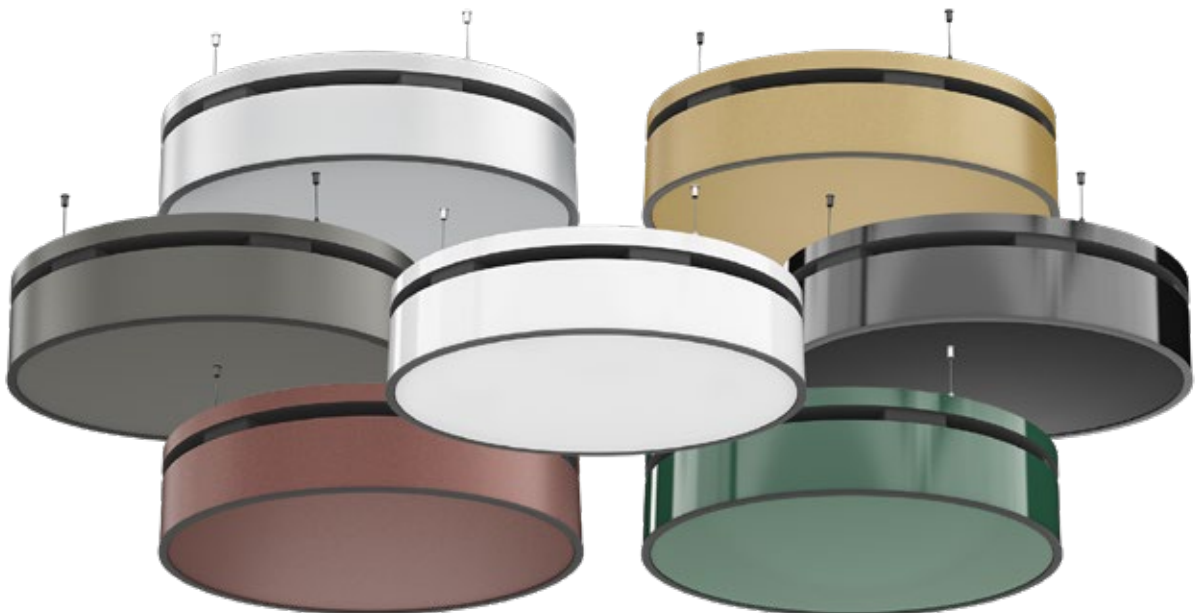

## Other design ideas

The unit can be integrated into the lighting concept and round lights can be used to enhance the visual appeal of the interior. In addition, foil can be applied to the unit to make it less conspicuous in the room.







# 04 ▶ Accessories



Article	Article	Properties	Dimensions	Suitable for	Article no.
			[mm]		

## Control accessories KaControl

### Attachments

	Wire cable suspension kit	2 m wire cable, continuously adjustable, 4 wire cables per 15 kg useful load, Colour galvanised		KaDius Fan Coils	<b>36001060001</b>
	Wire cable suspension kit	2 m wire cable, continuously adjustable, 4 wire cables per 15 kg useful load, Colour black		KaDius Fan Coils	<b>36001060002</b>

### Additional colours

	surcharge for RAL colour of your choice	Minimum quantity = 7 units per order and colour, The number of units below the minimum quantity must be requested and calculated separately. Price per unit.		KaDius mit Teilverkleidung Fan Coils	<b>360017010021</b>
				KaDius mit Vollverkleidung Fan Coils	<b>360017010022</b>
	surcharge for RAL standard colour	Price per unit.		KaDius mit Vollverkleidung Fan Coils	<b>360017010012</b>
				KaDius mit Teilverkleidung Fan Coils	<b>360017010011</b>
	surcharge for change of colour	of the powder-coating to the colour version quoted., The surcharge includes the conversion and cleaning of the powder-coating to the requested colour and will be charged once per project and call-off order.		KaDius Fan Coils	<b>360017010010</b>



[Kampmanngroup.com/kadius](https://Kampmanngroup.com/kadius)

Subject to technical modifications. 477/04/2026 EN

**Kampmann GmbH & Co. KG**  
Friedrich-Ebert-Str. 128-130  
49811 Lingen (Ems), Germany

+49 591 7108-0  
[info@kampmann.de](mailto:info@kampmann.de)

